

Vogt®

P-24AL

&

P-34AL

**TUBE-ICE®
MACHINE**

Service Manual

\$50⁰⁰

NOTICE

This manual is the property of the owner of this particular Tube-Ice® machine.

Model # _____ Serial # _____.

It is to be left on the premises with this machine at all times. After start-up, it should be stored in a safe place where it can be readily available when needed for future reference in maintaining troubleshooting or servicing.

Failure to comply with this notice will result in unnecessary inconvenience and possible additional expenses.

This manual is intended as an informational tool for the installation, operation, maintenance, troubleshooting, and servicing of this equipment. If an existing situation calls for additional information not found herein, we suggest that you contact your distributor first. If further assistance or information is needed, please feel free to contact the factory at 502-635-3000 or FAX at 502-635-3024 or 502-634-0479.

IMPORTANT: The Warranty Registration/Start-Up Report found in the front of this manual is to be completed and returned to the factory promptly after the official start-up.

Please return to: Tube Ice, LLC
 1000 W. Ormsby, Suite 19
 Louisville, KY 40210
 Att. Tube-Ice Service Department

Vogt® Tube-Ice® Machine
MID & LARGE MACHINE WARRANTY REGISTRATION/START-UP REPORT
 MUST COMPLETE AND RETURN TO INITIATE WARRANTY

Machine Model No. _____ Serial No. _____

Installed at: _____ () _____
 Company Name Phone

Address City State Zip

Installed by: _____ () _____ / ____ / ____
 Company Name Phone Date

Address City State Zip

Describe any damage to machine/repairs made: _____

Start up by: _____ () _____ / ____ / ____
 Company Name Phone Date

Address

Name of person starting up machine: _____

PRE START-UP CHECK

CHECK

- Service Manual on hand
- Machine room suitable 50°F minimum, 110°F maximum
- Proper power supply, actual voltage _____, _____, _____ (machine not running)
- Compressor crankcase heater on 12 hour minimum
- Necessary hand valves opened as required
- Solenoid valve stems in auto position
- System leak checked/tight
- Auxiliary equipment overloads wired into control circuit
- Compressor oil level _____ (1/4 glass min.)
- All water distributors in place (visually inspected)
- Water supply and drain lines installed and connected properly
- Compressor, pump, cutter and other motor direction of rotation correct
- Make-up water float valve adjusted properly
- Hour meter in control panel connected

OPERATION CHECK

Machine charged with refrigerant lbs. _____ Actual voltage _____, _____, _____ (machine running)

Ambient temp. _____ °F Fan cycles On _____ Off _____ Tower water in _____ °F out _____ °F

Comp motor RLA _____, _____, _____, Actual _____, _____, _____,

Pump RLA _____, _____, _____, Actual _____, _____, _____,

Cutter motor RLA _____, _____, _____, Actual _____, _____, _____,

Suction pressure end of freezing _____, end of harvest _____ Discharge pressure end of freezing _____, end of harvest _____

Evaporator/suction line frost _____ Receiver liquid level operating _____

Test Cycle	Water Temp	Freeze Time Min/Sec	Harvest Time Min/Sec	First Ice Out Min/Sec	All Ice Out Min/Sec	Avg. Hole Size	Ice Lb. Per Harvest	Ice Lb. Per Day
#1								
#2								
#3								
#4								

Note: Ice lb. per day can be found by: $\frac{\text{ice lb. per harvest}}{\text{(freeze time + harvest time)}} \times 1440$

The machine operated satisfactorily for _____ continuous hours. Date _____

Comments _____

Installer signature _____ End user signature _____

Please return to: Tube Ice LLC, 1000 W. Ormsby, Suite #19, Louisville, KY 40210

**VOGT®
TUBE-ICE® MACHINES**

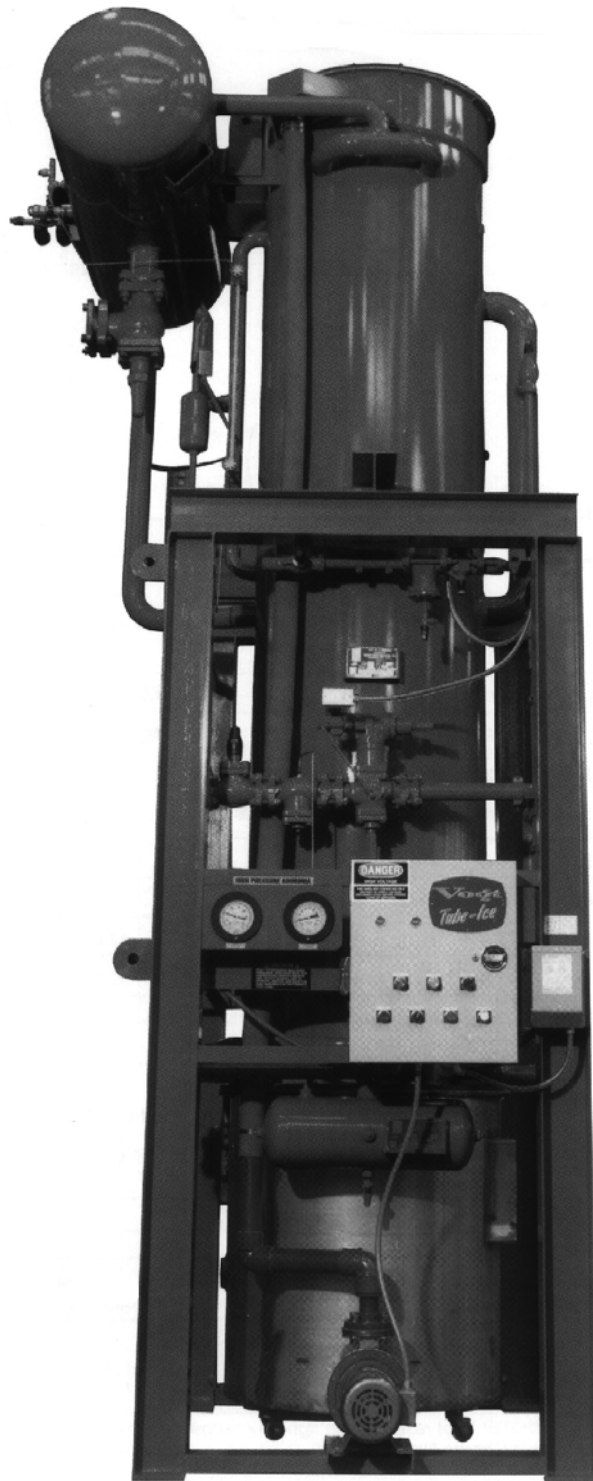

Installation, Service Manual, and Parts Catalog #12A-4171L14

Tube Ice, LLC
1000 W. Ormsby Avenue, Suite 19
Louisville, Kentucky, 40210
800-853-8648 • 502-635-3000
Fax: 502-634-0479

TABLE OF CONTENTS

Vogt[®] TUBE-ICE[®] MACHINES Model P24AL & P34AL

	Page No.
<u>1. INTRODUCTION</u>	
A Brief History Of Our Company	1-1
Vogt Energy-Savings Tube-Ice [®] Machines	1-1
Preview	1-1
Important Safety Notice.....	1-2
Safety Symbols and What They Mean	1-2
Special Precautions To Be Observed When Charging Refrigeration Systems	1-3
Assembly Drawing Model P24AL Tube-Ice [®] Machine	1-4, 5, 6, 7
Assembly Drawing Model P34AL Tube-Ice [®] Machine	1-8, 9, 10, 11
<u>2. RECEIPT OF YOUR TUBE-ICE MACHINE</u>	
Inspection	2-1
Description of Machine	2-1
Safety Tags and Labels.....	2-1
Model designation for P-Series Ice Machine, Figure 2-1	2-2
Storage (prior to installation and start-up)	2-2
<u>3. INSTALLING YOUR TUBE-ICE MACHINE</u>	
Machine Room	3-1
Space Requirements.....	3-1
Foundation3-1	
Lifting Procedures	3-1
P24AL Space Diagram, FIGURE 3-1.....	3-2,3-3
P24AL Foundation Layout, FIGURE 3-2.....	3-4
P34AL Space Diagram, FIGURE 3-3.....	3-5, 3-6
P34AL Foundation Layout, FIGURE 3-4.....	3-7
Lifting Procedure for P24AL, FIGURE 3-5	3-8
Lifting Procedure for P34AL, FIGURE 3-6	3-9
Lifting Procedure for P24AL, FIGURE 3-5	3-8
Seismic Anchoring Detail, FIGURE 3-7	3-10
Water Supply, Drain and Refrigeration Connections, TABLE 3-1	3-11
Make-Up Water In,.....	3-11
Flushing Water In	3-11
Water Tank Drain	3-11
Water Tank Overflow	3-12
Receiver	3-12
Receiver Volume Requirements, TABLE 3-2	3-12
	Page No.

TABLE OF CONTENTS

Suction Pressure Regulator.....	3-12
Compressor Unloading	3-12
Cooling Tower (optional).....	3-12
Total Heat Rejection Requirements, TABLE 3-3.....	3-13
Safety Valves	3-13
Freeze Protection, FIGURES 3-8, 3-9, 3-10.....	3-14, 3-15
Wiring and Electrical Connections.....	3-15
Power Supply Connections, FIGURE 3-11	3-16
Voltage Unbalance	3-16
Current Unbalance.....	3-17
Rotation Check	3-17
Auxiliary Controls or Equipment.....	3-18
Interconnecting Piping for Vogt P24AL and Vogt 24AHS, FIGURE 3-12.....	3-19
Interconnecting Piping for Vogt P24AL and Dedicated High Side, FIGURE 3-13.....	3-20
Interconnecting Piping for Vogt P34AL and Dedicated High Side, FIGURE 3-14.....	3-21
Interconnecting Piping for Vogt P24AL and Central High Side, FIGURE 3-15	3-22
Interconnecting Piping for Vogt P34AL and Central High Side, FIGURE 3-16.....	3-23
Interconnecting Piping for 2-Vogt P34AL and Central High Side, FIGURE 3-17.....	3-24
Interconnecting Piping for 3-Vogt P34AL and Central High Side, FIGURE 3-18.....	3-25
Installation Review: A Checklist.....	3-26

HOW YOUR TUBE-ICE MACHINE WORKS

Operating Features.....	4-1
Principle of Operation.....	4-1
Freeze Period.....	4-1
Harvest Period	4-2
Piping Nomenclature	4-2
Piping Schematic for P24AL, FIGURE 4-1.....	4-3
Piping Schematic for P34AL, FIGURE 4-2.....	4-4

5. START-UP AND OPERATION

Refrigeration System Review	5-1
Start-up Checklist	5-2
Refrigerant Charge	5-2
Ammonia Specification By Grade, TABLE 5-1	5-2
Special Precautions to be Observed when Charging Refrigeration Systems	5-2
Charging From Tank Truck (for dedicated high side only)	5-3
Charging From Cylinders (for dedicated high side only)	5-3
Control Panel, FIGURE 5-1.....	5-5
Start-Up	5-5
Adding Refrigerant.....	5-6
Operating Tips	5-6
Thaw Gas Regulating and Suction Regulating Valve Adjustment	5-7

6. ELECTRICAL CONTROLS & THEIR FUNCTIONS

TABLE OF CONTENTS

Bin Level Control6-1

Safety Switches6-1

Control Panel (Door Opened), FIGURE 6-1.....6-2

Description of Control Panel Parts (Inside), TABLE 6-16-2

Control Panel (Door Closed), FIGURE 6-2.....6-3

Description of Control Panel Parts (Outer Door), TABLE 6-2.....6-3

Electrical Schematic All Voltages 50-60 Hz. Across Line Start, FIGURE 6-36-4

7. MAINTENANCE

Preventive Maintenance.....7-1

Preventative Maintenance Form7-2

Ice-Making Section.....7-3

Cleaning Procedure.....7-3

Water Distributors7-3

Water Distributors, TABLE 7-17-4

Average Hole Size in Tube-Ice®, TABLE 7-2.....7-4

Water Tank7-4

Water Cooled Condenser Cleaning (optional).....7-5

Cooling Tower / Evap Condenser (optional)7-5

Compressor (optional)7-6

Compressor Maintenance, TABLE 7-47-7

Oil Trap7-7

Cutter Gear Reducer7-7

8. TROUBLESHOOTING

List Of Symptoms.....8-1

Machine Stopped8-2, 8-3

Freeze-Up Due To Extended Freezing Period8-4

Freeze-Up Due To Ice Failing To Discharge8-5

Low Ice Capacity8-6, 8-7

Poor Ice Quality8-7

High Discharge Pressure.....8-8

Low Discharge Pressure8-9

High Suction Pressure.....8-9

Compressor Running Unloaded During Freeze8-9

Compressor Oil Pressure Low8-10

Compressor Loosing Oil Excessively8-10

Machine Short Cycles.....8-11

High Compressor Discharge Temperature.....8-11

Suction Line Frosting To Compressor8-11

TABLE OF CONTENTS

	Page No.
<u>9. SERVICE OPERATIONS</u>	
Automatic Blowdown (Harvest Cycle).....	9-1
Cleaning the Ice Making Section.....	9-1
Float Valve (Make-Up Water).....	9-1
Float Switch.....	9-1
P24AL and P34AL Float Height, FIGURE 9-1, TABLE 9-1	9-2
Hand Expansion Valve	9-2
Freeze Timer.....	9-2
Minature Rocker Switch Settings for Freeze Timer	9-3
Entering and Displaying Setpoints	9-3
Freeze Timer, FIGURE 9-2	9-4
Freezer Pressure Switch (optional)	9-4
Freezer Pressure Switch, FIGURE 9-1	9-5
Control Circuit Protection.....	9-5
Thawing Timer	9-5
Thawing Timer, FIGURE 9-4.....	9-6
Suggested Condenser Cleaning	9-6
Cutter Gear Reducer	9-7
Drive Gear Replacement.....	9-7
Gear Reducer Replacement	9-8
Water Tank and Cutter Parts Weights, TABLE 9-1	9-9
Water Tank Removal.....	9-9
Cutter Assembly Removal and Installation	9-10
Bearing Bracket and Cutter Disc Removal	9-10
Cutter Shaft and Bearing Removal	9-11
Cutter Shaft and Bearing Installation.....	9-11
Cutter Height Adjustment.....	9-13
Water Tank Installation	9-13
P24A Cutter Assembly, FIGURE 9-5A.....	9-14
P24A Water Tank Assembly, FIGURE 9-5B	9-15
P24A and P34A Cutter and Water Tank Part No., TABLE 9-2.....	9-16, 9-17
Cutter Ring Gear Replacement.....	9-17
Cutter Blade Replacement	9-17
Cutter Blade and Adapter Plate Adjustment, FIGURE 9-6	9-18
Cutter Adapter Plate Installation.....	9-18
Pumpdown9-19	
Removal of Ammonia Refrigerant from the Machine	9-19
Refrigerant Leaks	9-20
Non-Condensable Gases.....	9-20
Purging Non-Condensables	9-20
Draining the Oil Trap	9-21
Removing Excess Water from Ammonia	9-22
	Page No.

Circulating Water Pump Motor9-23

The Thaw Gas Solenoid Valve9-23

Thaw Gas Solenoid Valve, FIGURE 9-7.....9-24

The Liquid Feed Solenoid Valve9-24

The Liquid Feed Solenoid Valve, FIGURE 9-8.....9-25

The Thaw Chamber Check Valve.....9-25

The Thaw Chamber Check Valve, FIGURE 9-99-25

Water Flush Solenoid Valve9-26

Compressor Cooling Solenoid Valve (dedicated high side only)9-26

Compressor Oil Changing9-26

Compressor Inspection9-26

Belt Tension.....9-27

Compressor Servicing.....9-28

10. OPTIONS AND ACCESSORIES

Crushed Ice Production 10-2

Length of Ice 10-2

PLC (Programmable Logic Controller) 10-3

Reduced Voltage Cutter Motor Starter 10-13

11. TABLES AND CHARTS

P24AL Specifications, TABLE 11-1 11-2

P34AL Specifications, TABLE 11-2 11-3

P24AL Make-up Water Usage, TABLE 11-3..... 11-4

P34A Make-up Water Usage, TABLE 11-4 11-4

P24A Normal Operating Vitals, TABLE 11-5..... 11-5

P34A Normal Operating Vitals, TABLE 11-6..... 11-5

Recommended Spare Parts List 11-6

Temperature - Pressure Chart for Common Refrigerants, TABLE 11-7 11-7

Conversion Factors: English to Metric, TABLE 11-8 11-8

Constants, TABLE 11-9 11-8

12. APPENDIX

TABLE OF CONTENTS

1. Introduction

Vogt Tube Ice, LLC

A Brief History Of Our Company. Henry Vogt Machine Co. was founded as a small machine shop in Louisville, Kentucky in 1880. Today, Vogt Tube Ice, LLC is one of the world's leading producers of ice-making equipment.

In 1938, Vogt built the first Tube-Ice® machine and revolutionized the ice-making industry. Our first "sized-ice" machine quickly replaced the old can-ice plants, which required hard labor and large amounts of floor space for freezing, cutting, and crushing ice by hand.

Vogt Energy-Saving Tube-Ice Machines Are Cost Effective. Today, Vogt Tube-Ice® machines enjoy a well-earned reputation as the most energy efficient, dependable ice-making equipment in the world.

Using as little as one-half to one-third the energy required by competitors' ice makers, Tube-Ice® machines produce the same amount of ice--in restaurants, sports arenas, packing plants, and wholesale operations around the globe--at great savings.

In addition, Tube-Ice® machines are renowned for their long life, giving many customers more than 35 years of dependable service. **Ask someone who owns one.**

Preview. All the skill in engineering and fabrication that we've learned in over a century of experience is reflected in every Tube-Ice® machine. Since Vogt introduced Tube-Ice® machines in 1938, the process of making Tube-Ice® ice has been widely recognized as the most economical means of production. The machine's economic and reliable operation has been proven over and over again, in a network of varied types of installations throughout the world.

This manual is designed to assist you in the installation, start-up, and maintenance of your unit. Your Tube-Ice® machine will give you a lifetime of service provided you install, maintain, and service it properly. It is evidence of our desire to deliver to you "the finest ice-making unit ever made."

Please read your manual carefully before attempting installation, operation, or servicing of this professionally-designed piece of equipment. Also, make sure the Warranty Registration/Start-up Report is completed and returned.

If you have additional questions, please call your distributor. Also, feel free to phone the factory direct at **(502) 635-3000**.

INTRODUCTION

Important Safety Notice. This information is intended for use by individuals possessing adequate backgrounds in electrical, refrigeration and mechanical experience. Any attempt to repair major equipment may result in personal injury and/or property damage. The manufacturer or seller cannot be responsible for the interpretation of this information, nor can it assume any liability in connection with its use. It is important that personnel understand the properties of this refrigerant and that they be thoroughly trained in safe practices for its use and handling. Refer to the enclosed “Anhydrous Ammonia Safety” in Appendix A.

Safety Symbols & What They Mean. Prior to installation or operation of the Tube-Ice® machine, please read this manual. Are you familiar with the installation, start-up, and operation of a Tube-Ice® machine? Before you operate, adjust or service this machine, you should read this manual, understand the operation of this machine, and be aware of possible dangers.

These safety symbols will alert you

when special care is needed.

Please heed them.

! DANGER !
Indicates an immediate hazard and that special precautions are necessary to avoid severe personal injury or death.
! DANGER !

! WARNING !
Indicates a strong possibility of a hazard and that an unsafe practice could result in severe personal injury.
! WARNING !

! CAUTION !
Means hazards or unsafe practices could result in personal injury or product or property damage.
! CAUTION !

Special Precautions To Be Observed When Charging Refrigeration Systems. Only technically-qualified persons, experienced and knowledgeable in the handling of anhydrous ammonia refrigerant and operation of refrigeration systems, should perform the operations described in this manual. All local, federal, and EPA regulations must be strictly adhered to when handling ammonia (R-717) refrigerant. See “Material Safety Data Sheet”, MSDS Code No. 5B81-83.

If a refrigeration system is being charged from refrigerant cylinders, disconnect each cylinder when empty or when the system is fully charged. A gage should be installed in the charging line to indicate refrigerant cylinder pressure. The cylinder may be considered empty of liquid R-717 refrigerant when the gauge pressure is 25 pounds or less, and there is no frost on the cylinder. Close the refrigerant charging valve and cylinder valve before disconnecting the cylinder. Loosen the union in the refrigerant charging line--carefully to avoid unnecessary, excessive or illegal release of refrigerant into the atmosphere.

! CAUTION !

Immediately close system charging valve at commencement of defrost or thawing cycle if refrigerant cylinder is connected. Never leave a refrigerant cylinder connected to system except during charging operation. Failure to observe either of these precautions can result in transferring refrigerant from the system to the refrigerant cylinder, over-filling it, and possibly causing the cylinder to rupture because of pressure from expansion of the liquid refrigerant brought on by an increase in temperature.

! CAUTION !

Always store cylinders containing refrigerant in a cool place. They should never be exposed to temperatures higher than 120°F and should be stored in a manner to prevent abnormal mechanical shocks.

Also, transferring refrigerant from a refrigeration system into a cylinder can be very dangerous and is not recommended.

! CAUTION !

It is not recommended that refrigerant be transferred from a refrigeration system directly into a cylinder. If such a transfer is made, the refrigerant cylinder must be an approved, CLEAN cylinder--free of any contaminants or foreign materials--and must be weighed continuously to assure contents do not exceed net weight specified by cylinder manufacturer or any applicable code requirements.

! CAUTION !

INTRODUCTION

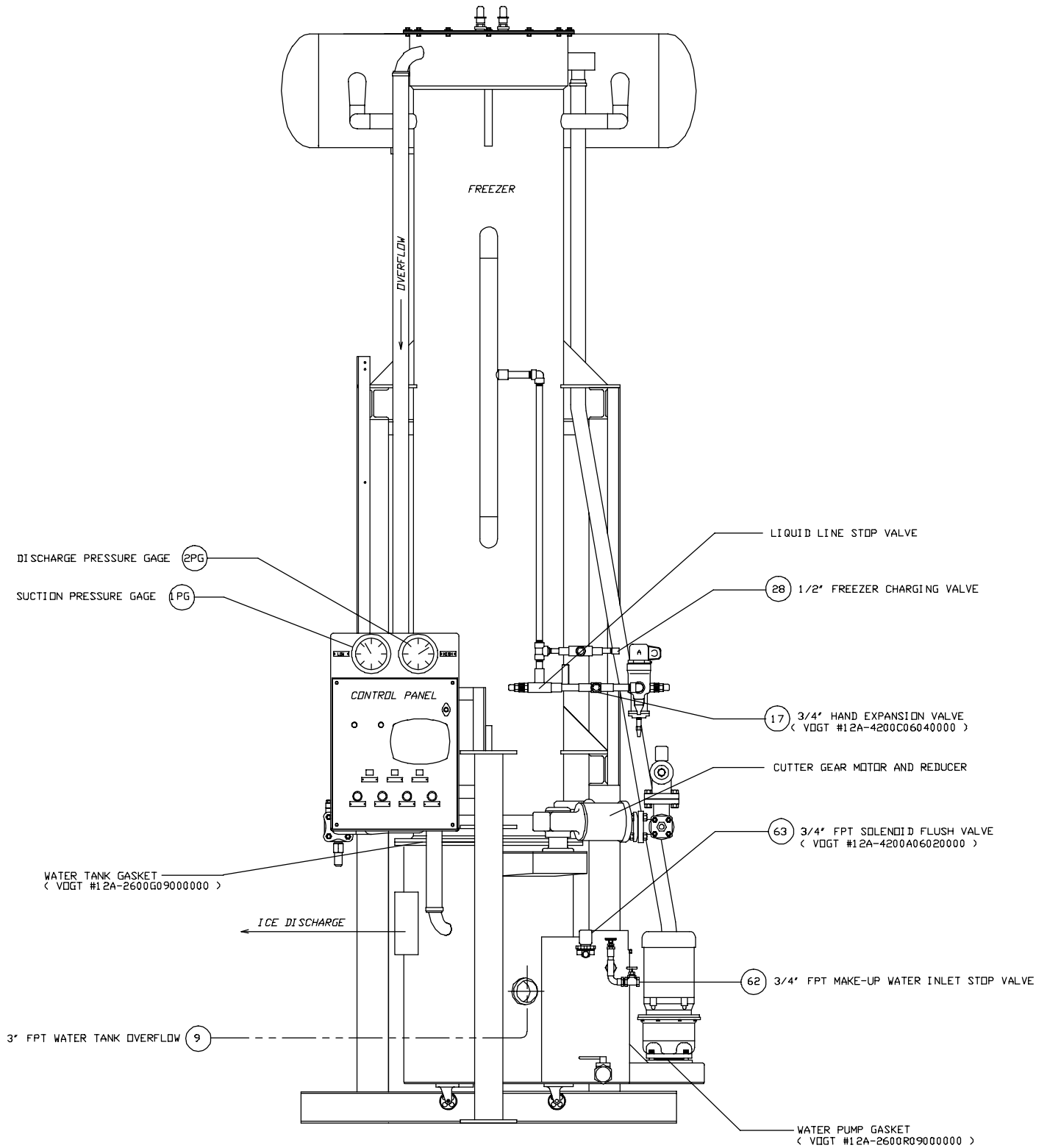

FIGURE 1-1
P24AL 1" Front Side (Control Panel)

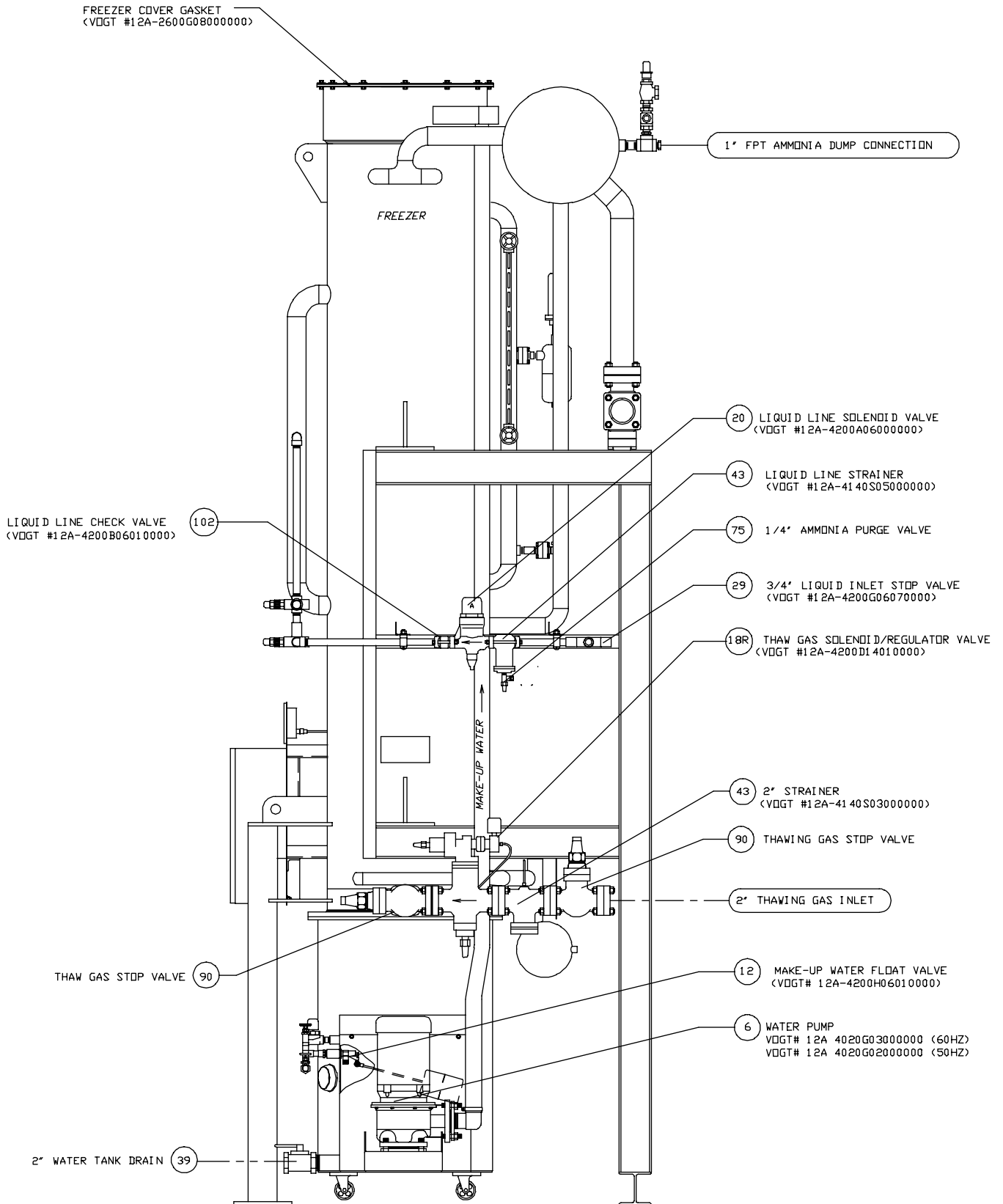

FIGURE 1-2
P24AL Right Side

INTRODUCTION

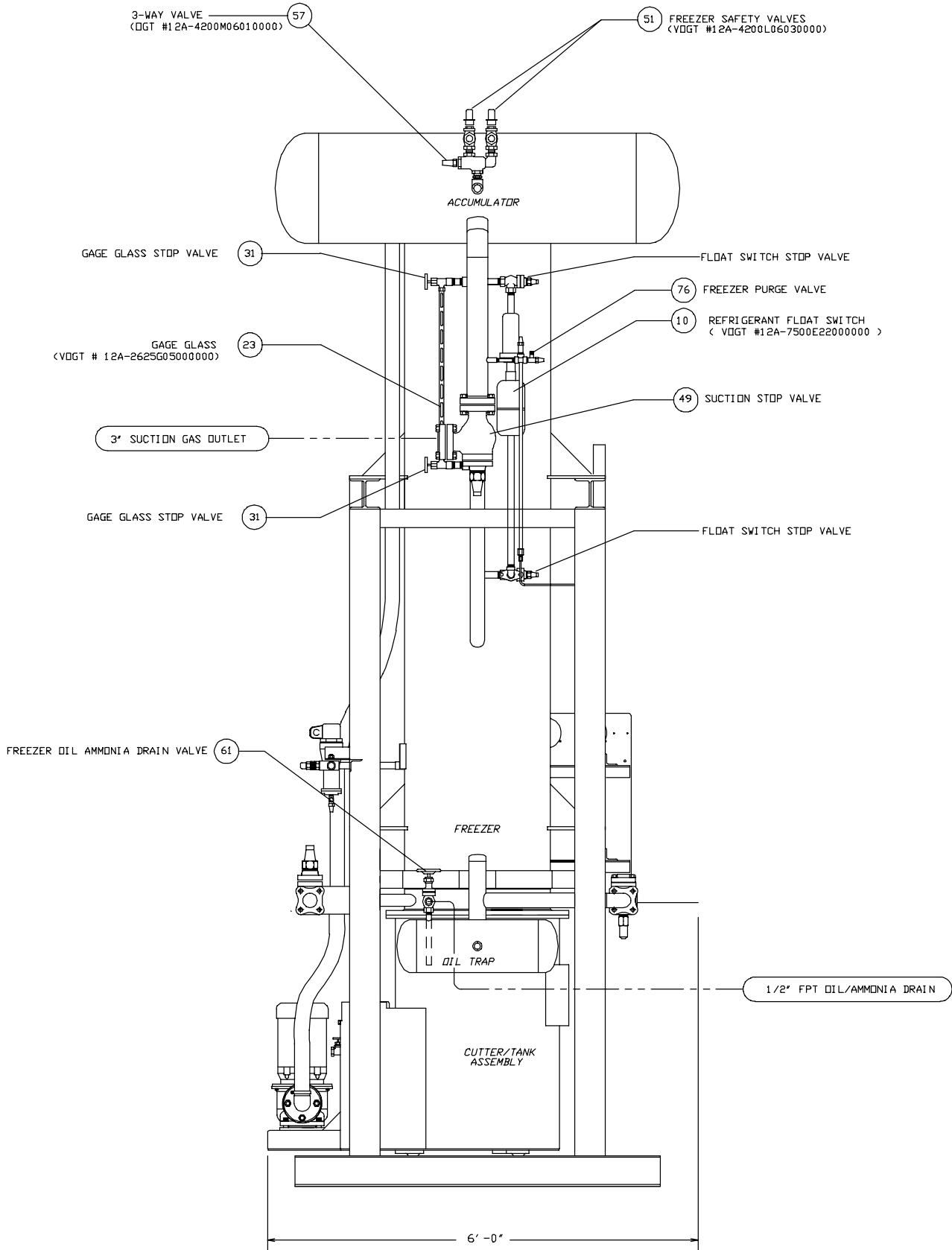

FIGURE 1-3
P24AL Back Side

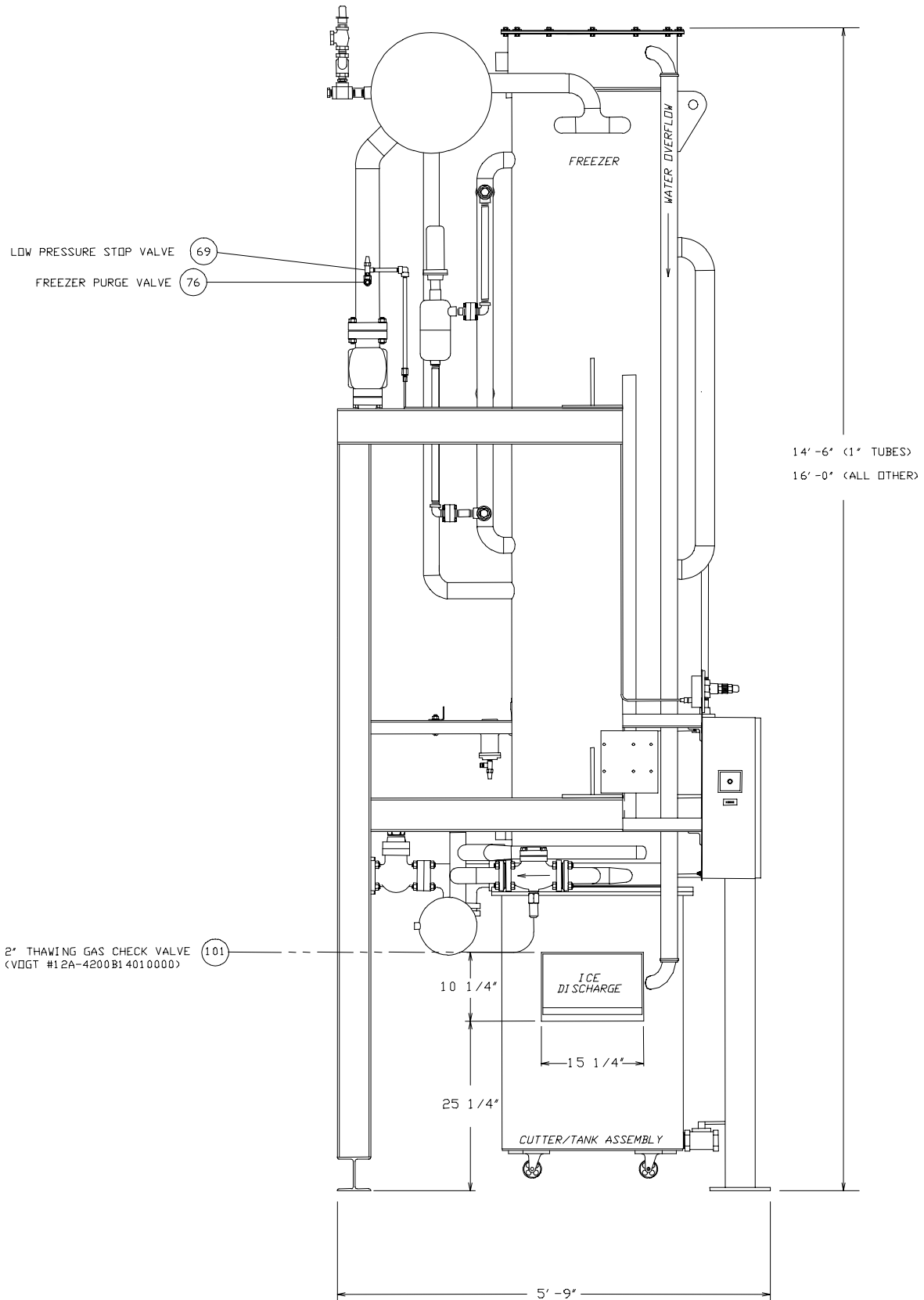

FIGURE 1-4
P24AL Left Side

INTRODUCTION

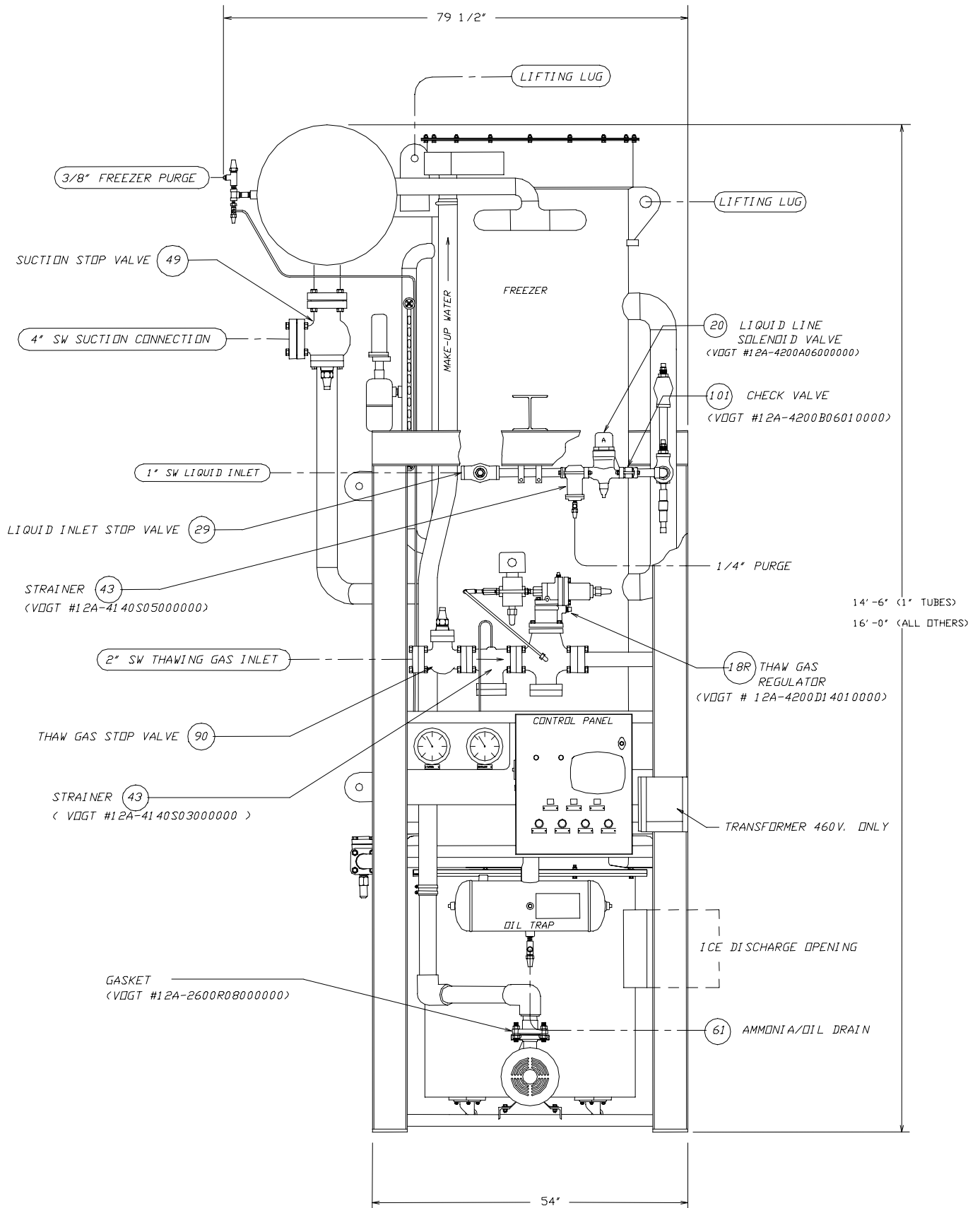

FIGURE 1-5
P34AL Front Side (Control Panel)

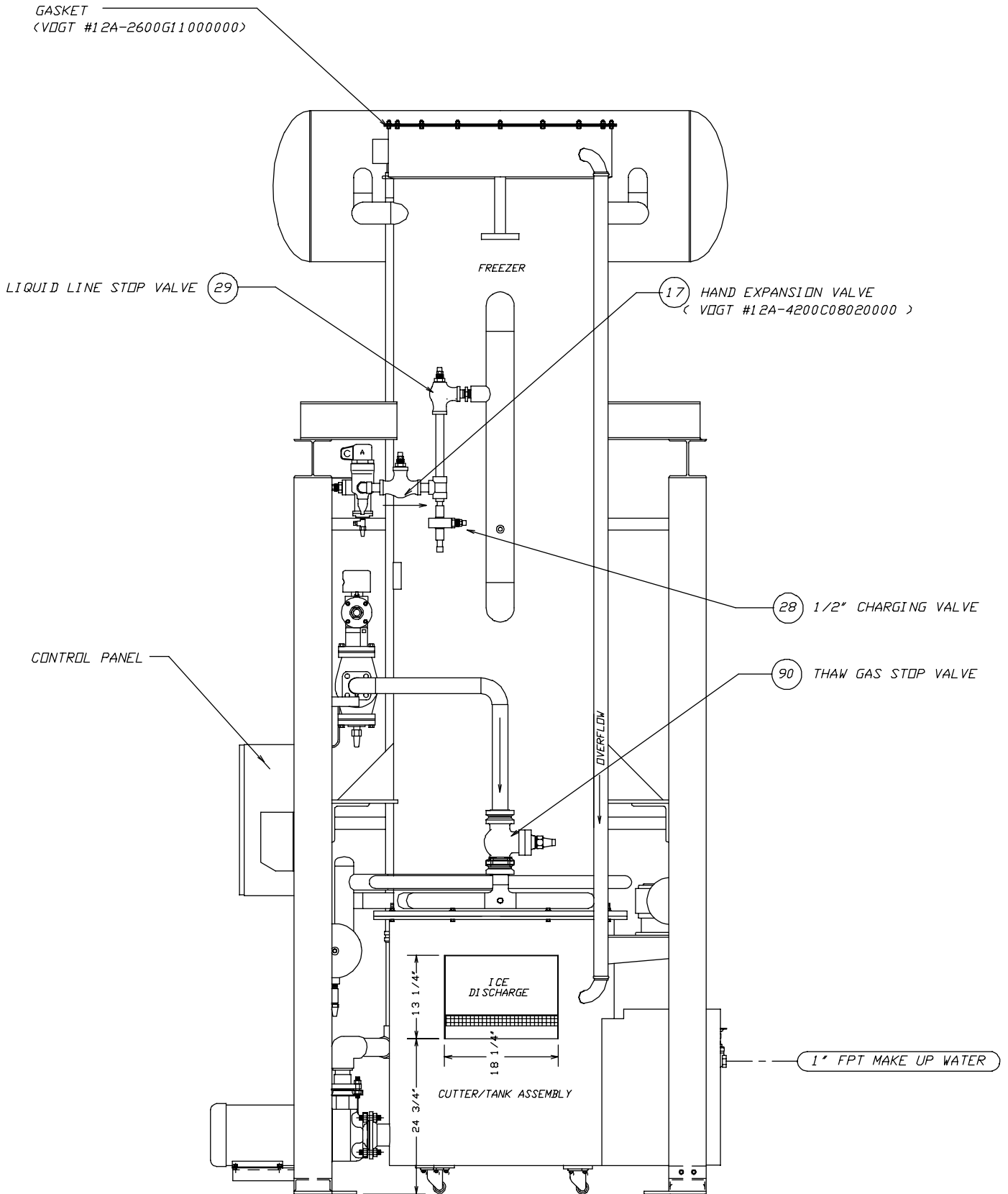

FIGURE 1-6
P34AL Right Side

INTRODUCTION

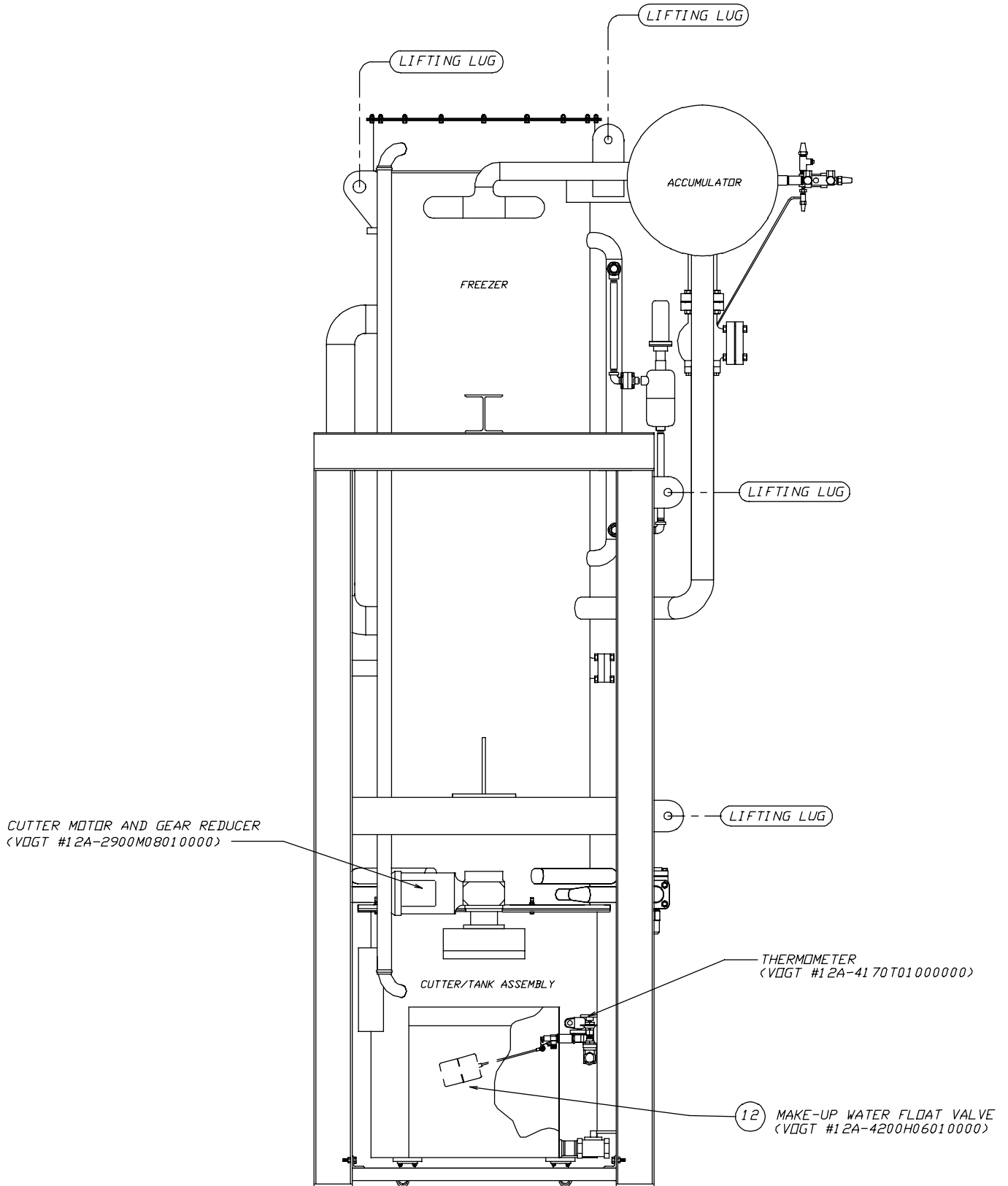

FIGURE 1-7
P34AL Back Side

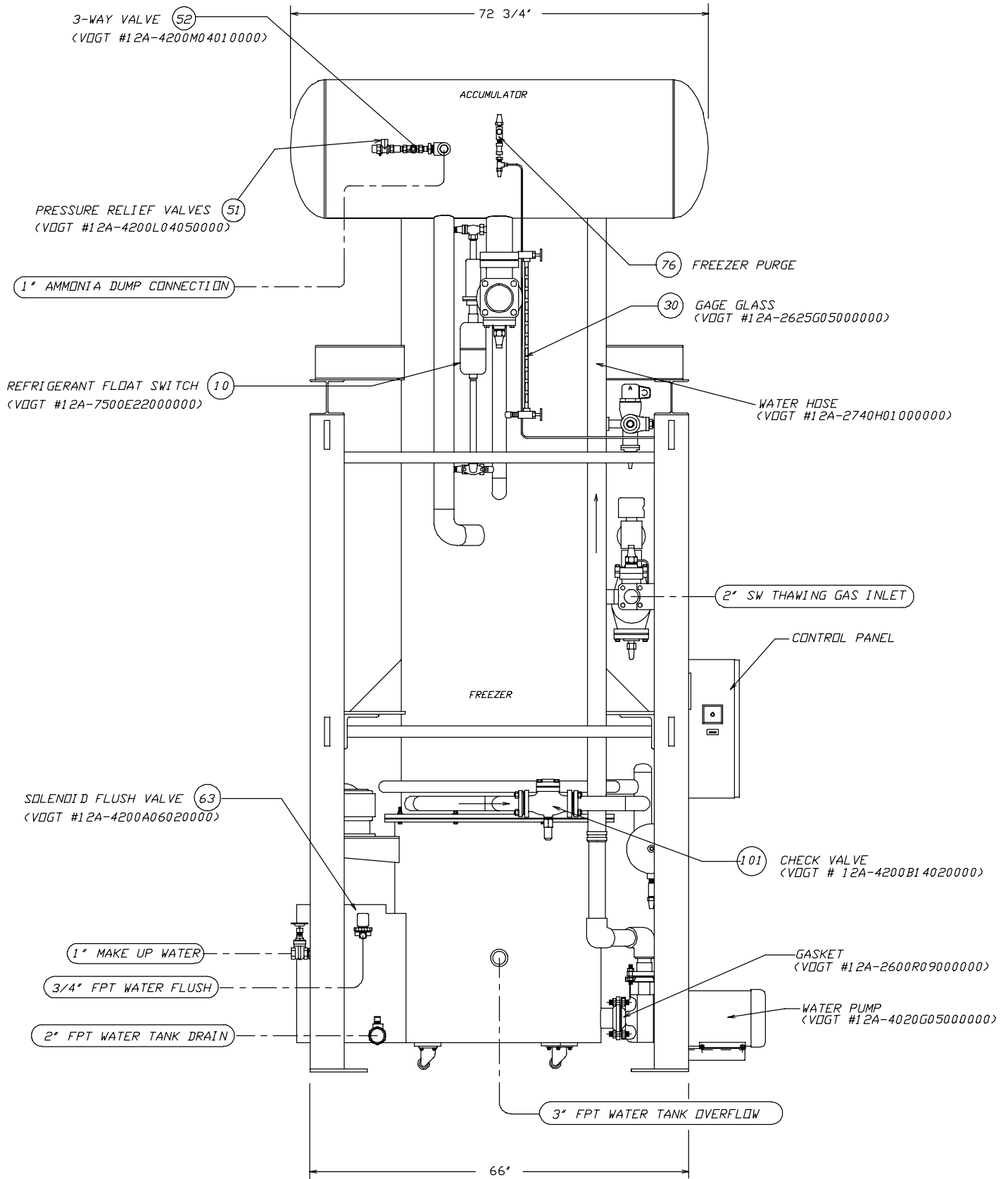

FIGURE 1-8
P34AL Left Side

INTRODUCTION

2. Receipt Of Your Tube-Ice Machine

! CAUTION !

Only service personnel experienced in ammonia refrigeration and qualified to work on high amperage electrical equipment should be allowed to install or service this Tube-Ice[®] machine.

Eye protection should be worn by all personnel working on or around the Tube-Ice[®] machine.

It is very important that you are familiar with and adhere to all local, state, and federal, etc. ordinances and laws regarding the handling, storing, and use of anhydrous ammonia.

An approved ammonia mask should be readily available for use in an emergency and all personnel should be aware of its location and proper use.

! CAUTION !

Inspection. As soon as you receive your machine, inspect it for any damage. If damage is suspected, note it on the shipper's papers (i.e., the trucker's Bill of Lading). **Immediately** make a separate written request for inspection by the freight line's agent. Any repair work or alteration to the machine without the permission of the Henry Vogt Machine Co. can void the machine's warranty. You should also notify your Vogt distributor or the factory.

Description Of Machine. A Vogt low side Tube-Ice[®] machine is a remote ice producing plant requiring refrigerant suction connection, refrigerant liquid connection, thaw gas connection, make-up water supply, electrical connection, and the proper refrigerant charge.

The machine has been partially factory tested prior to shipment and will require adjustment to meet the high side (condenser unit) operating conditions. See Start-up and Operation for the correct setting of the controls.

After factory pressure testing of the machine, the machine is evacuated and charged with nitrogen gas pressure for shipment. This prevents air or moisture from entering the system during transit. There should be a positive pressure (20-25 psig) indicated on the control panel gages when the machine is received. The machine has been cleaned with ice machine cleaner and flushed so that the machine is ready for ice production.

Safety Tags and Labels. Be sure to read and adhere to all special tags and labels attached to valves or applied to various areas of the machine. They provide important information necessary for safe and efficient operation of your equipment.

The machine is available in three different tube sizes for producing ice 7/8" OD x 1" long, 1 1/8" OD x 1" long, or 1 3/8" OD x 1" long. The ice is cut to length by a rotating breaker type cutter. Ice can be produced up to 1 1/2" long by modifying the spacers under the adapter plates (see Chapter 10, "Ice Length" for modifying instructions). Crushed ice is also available by modifying the cutter and making minor adjustments to the machine (see Chapter 10, "Crushed Ice").

RECEIPT OF YOUR TUBE-ICE MACHINE

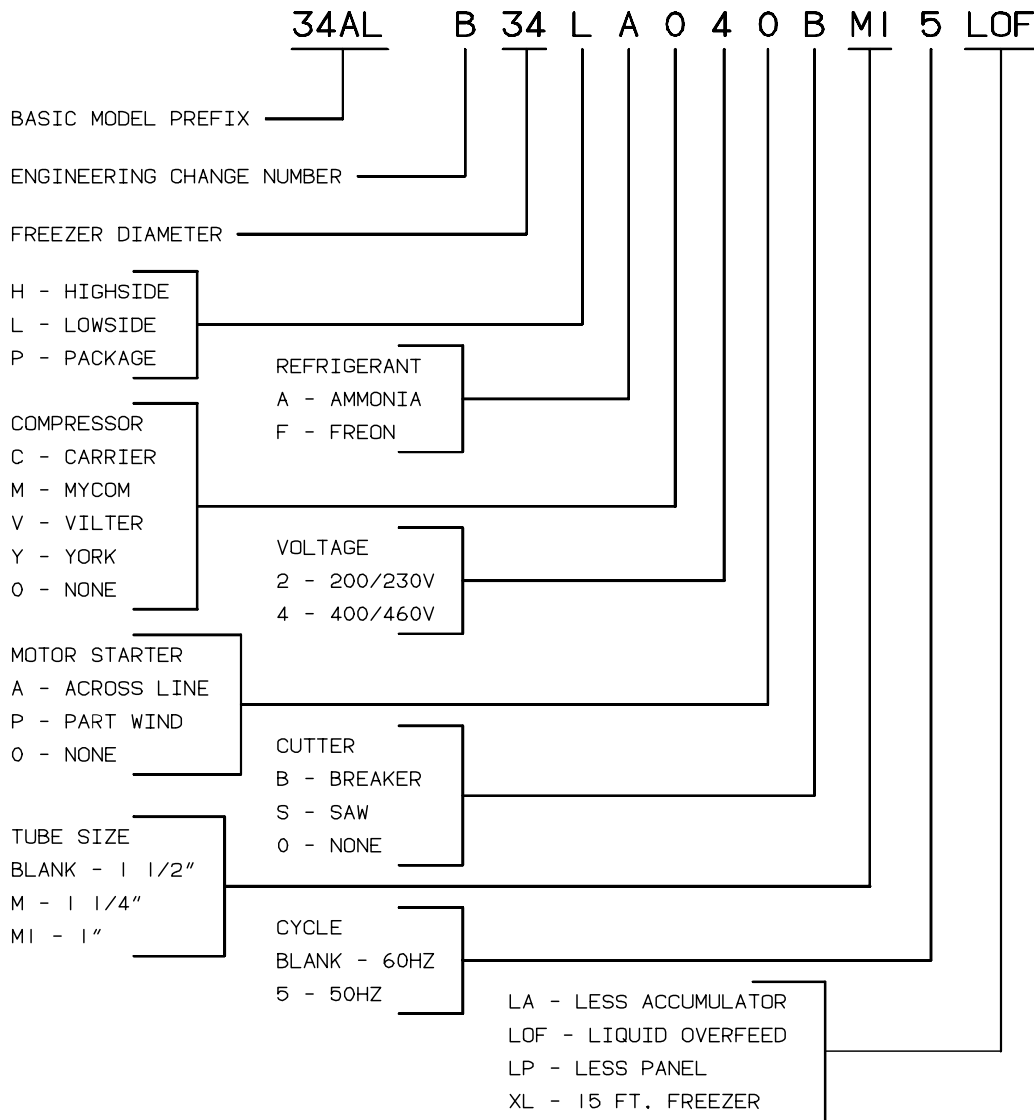

FIGURE 2-1
Model Designation for P-Series Ice Machines

Rated Capacity. The Tube-Ice[®] machine is rated to produce a given amount of ice when operating under the proper conditions as specified in this manual (see Section 11 for the operating specifications). You should be prepared to handle the ice produced as it is discharged from the machine and move it to your storage or bagging area promptly.

Storage (prior to installation or start-up). The machine must not be stored or installed in an area that is subject to reach temperatures at or above 110°F (43.3°C).

3. Installing Your Tube-Ice Machine

Your machine will be shipped to you as one package. You will need to arrange for the handling of the package as soon as it arrives, see the machine specifications Section 11 for shipping and operating weight. Before you remove the unit from the truck, be certain that any sign of damage, however slight, is noted on the carrier's papers.

Note: See "Lifting Procedure" drawing furnished with this manual, Fig 3-5 and 3-6.

Machine Room. The machine must be located inside a suitable building and must not be subjected to ambient temperatures below 50°F (10°C) or above 110°F (43.3°C). Heat radiation from other sources (sunlight, furnaces, condenser, etc.) and unusual air current may affect the operation of the machine and should be avoided. **The electrical components of the Tube-Ice® machine are rated NEMA 1. Therefore, the machine should not be located in a hazardous area or sprayed with water.** The machine should be installed in an area where water will not stand, but will readily drain away from the machine.

Space Requirements. Refer to the space diagrams, Figures 3-1 and 3-3, for recommended minimum clearance around the machine for ease of servicing and observation. Pay particular attention to the additional space required. If it ever becomes necessary to mechanically clean the condenser tubes, extra space will be required on one end (preferably on the opposite end from the water inlet and outlet) for the cleaning tools.

Foundation. Refer to the space diagrams, Figures 3-2 and 3-4, for recommended minimum foundation requirements. The figures show anchor bolt details and machine anchor hole details. Contact your local distributor for seismic anchoring requirements in your area.

! WARNING !
Lifting or moving heavy equipment should only be attempted by competent rigging and hoisting contractors. Never allow personnel near or under heavy equipment when it is being moved or lifted. Failure to comply could result in personal injury or loss of life.
! WARNING !

Lifting Procedures. Your Tube-Ice® machine is provided with lifting lugs for the purpose of unloading and moving the machine to its operation location. Refer to the enclosed drawings for instructions and illustrations of their use.

P24AL - Figure 3-5. Machine weight 6,200 lbs.

P34AL- Figure 3-6. Machine weight 10,000 lbs.

These figures are intended as a guide to unloading and lifting the P24AL and P34AL Tube-Ice® machine. **The Henry Vogt Machine Co. is not responsible for product damage or personnel injury or loss of life during the loading or lifting procedure.**

INSTALLING YOUR TUBE-ICE MACHINE

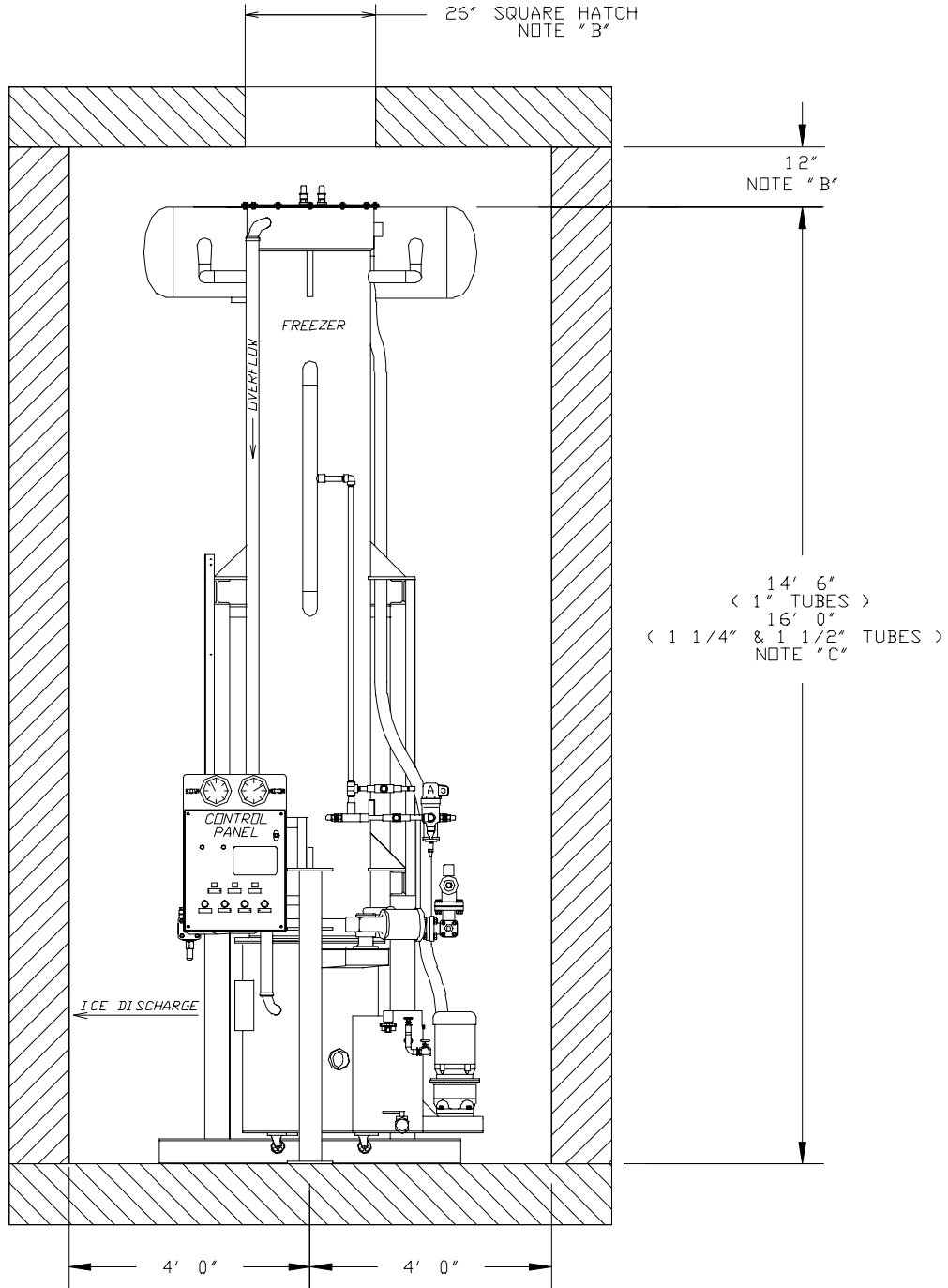

- NOTES -
- A. REQUIRED TO SERVICE ELECTRICAL CONTROLS AND CUTTER ASSEMBLY.
 - B. REQUIRED ABOVE FREEZER TO SERVICE FREEZER TUBES.
 - C. MACHINE SHOWN WITH STD. SUPPORT, INCREASE AS REQUIRED TO ACCOMMODATE EXTENDED BASE, IF USED.

CUSTOMER NOTES : THIS DRAWING IS INTENDED TO BE USED AS A GUIDE ONLY FOR MINIMUM SPACE REQUIREMENT FOR SERVICING AND OPERATING A P24AL TUBE - ICE MACHINE. SPACE REQUIREMENTS FOR OTHER EQUIPMENT SUCH AS CONVEYORS, AUGERS, ETC. MUST BE CONSIDERED.

FIGURE 3-1A
P24AL Space Diagram (Front View)

INSTALLING YOUR TUBE-ICE MACHINE

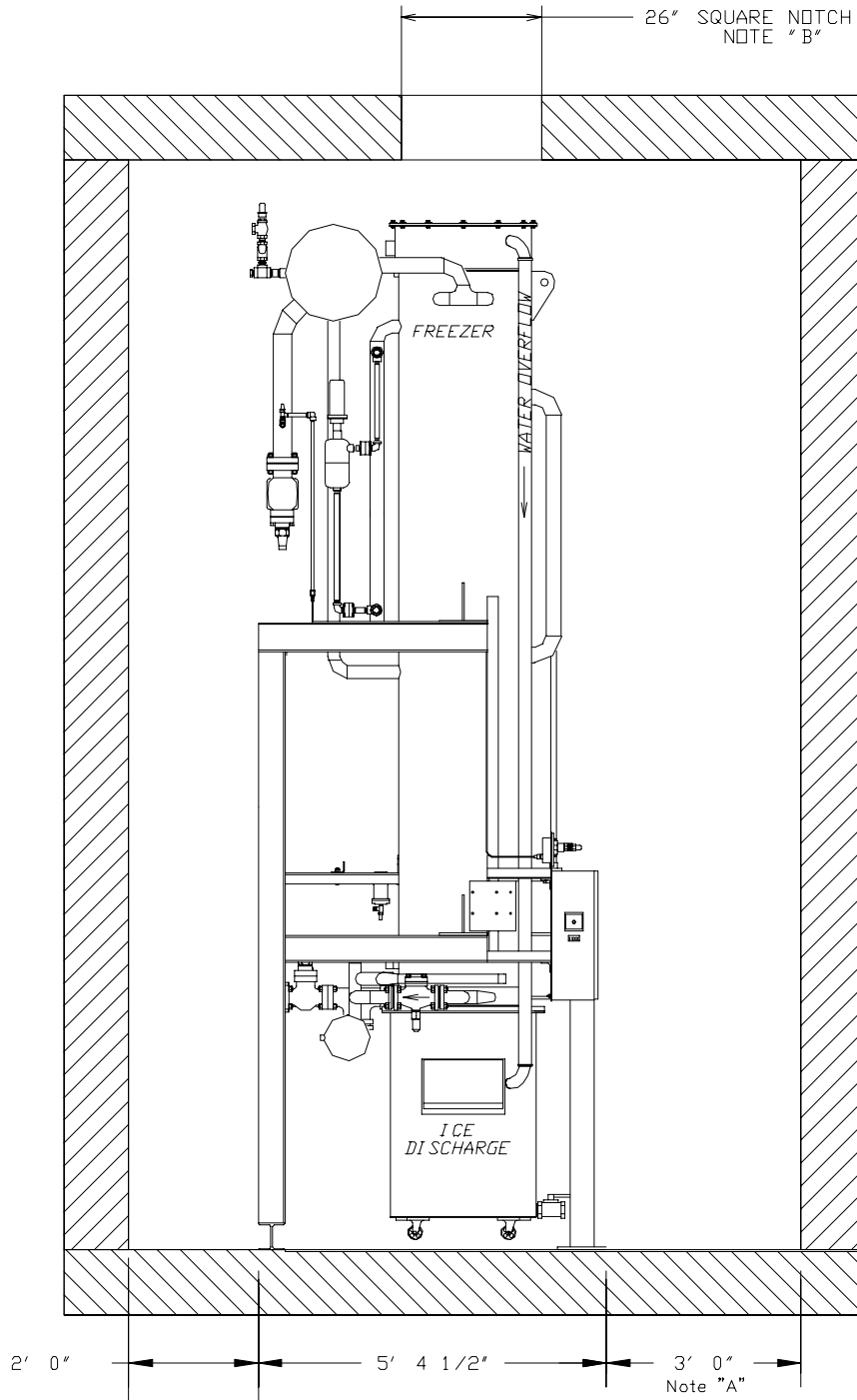

NOTES -

- A. REQUIRED TO SERVICE ELECTRICAL CONTROLS AND CUTTER ASSEMBLY.
- B. REQUIRED ABOVE FREEZER TO SERVICE FREEZER TUBES.
- C. MACHINE SHOWN WITH STD. SUPPORT, INCREASE AS REQUIRED TO ACCOMMODATE EXTENDED BASE, IF USED.

CUSTOMER NOTES : THIS DRAWING IS INTENDED TO BE USED AS A GUIDE ONLY FOR MINIMUM SPACE REQUIREMENT FOR SERVICING AND OPERATING A P24AL TUBE - ICE MACHINE. SPACE REQUIREMENTS FOR OTHER EQUIPMENT SUCH AS CONVEYORS, AUGERS, ETC. MUST BE CONSIDERED.

FIGURE 3-1B
P24AL Space Diagram (Side View)

INSTALLING YOUR TUBE-ICE MACHINE

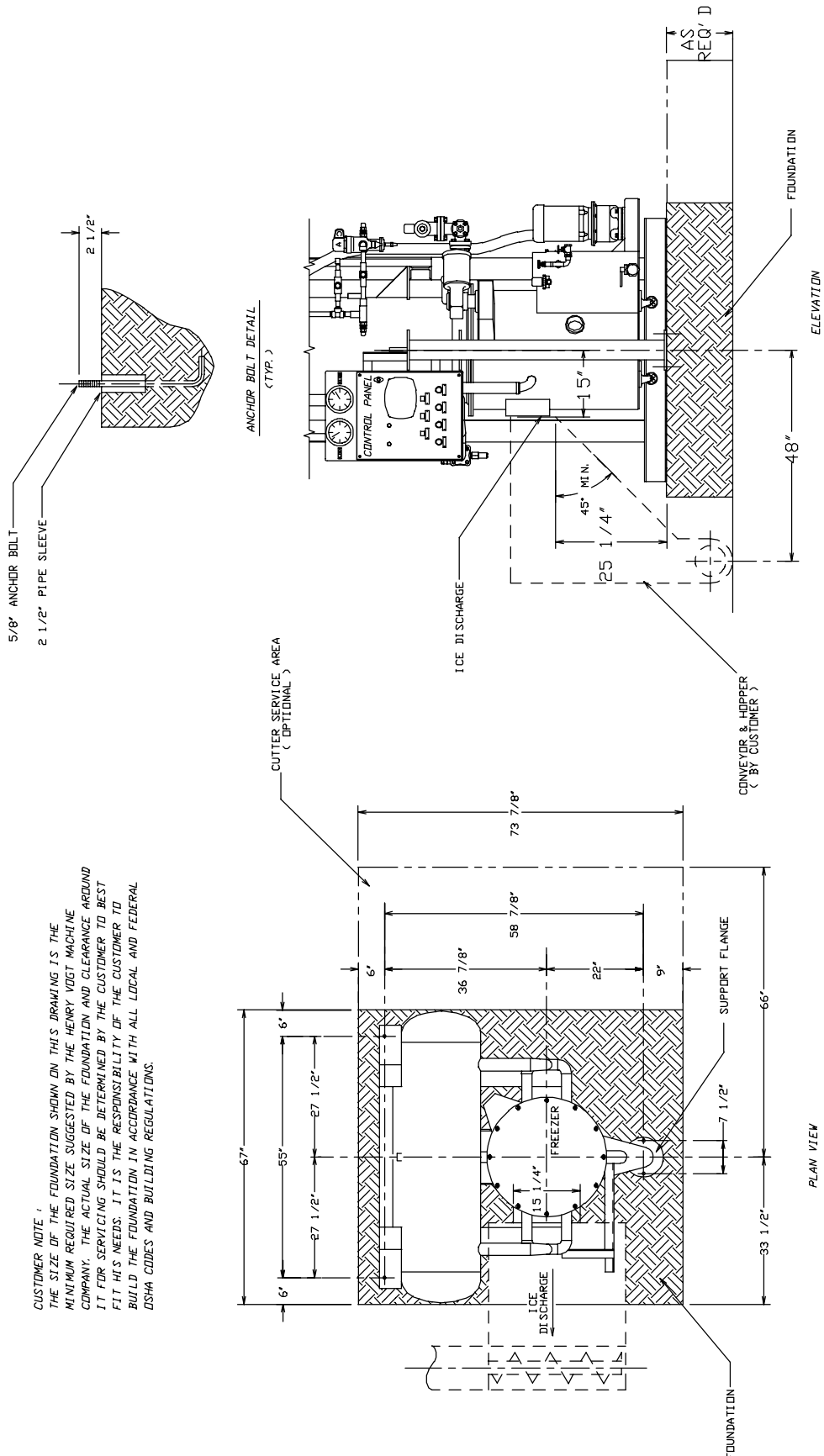

CUSTOMER NOTE:
 THE SIZE OF THE FOUNDATION SHOWN ON THIS DRAWING IS THE MINIMUM REQUIRED SIZE SUGGESTED BY THE HENRY VOGT MACHINE COMPANY. THE ACTUAL SIZE OF THE FOUNDATION AND CLEARANCE AROUND IT FOR SERVICING SHOULD BE DETERMINED BY THE CUSTOMER TO BEST FIT HIS NEEDS. IT IS THE RESPONSIBILITY OF THE CUSTOMER TO BUILD THE FOUNDATION IN ACCORDANCE WITH ALL LOCAL AND FEDERAL OSHA CODES AND BUILDING REGULATIONS.

**FIGURE 3-2
 P24AL Foundation Layout**

INSTALLING YOUR TUBE-ICE MACHINE

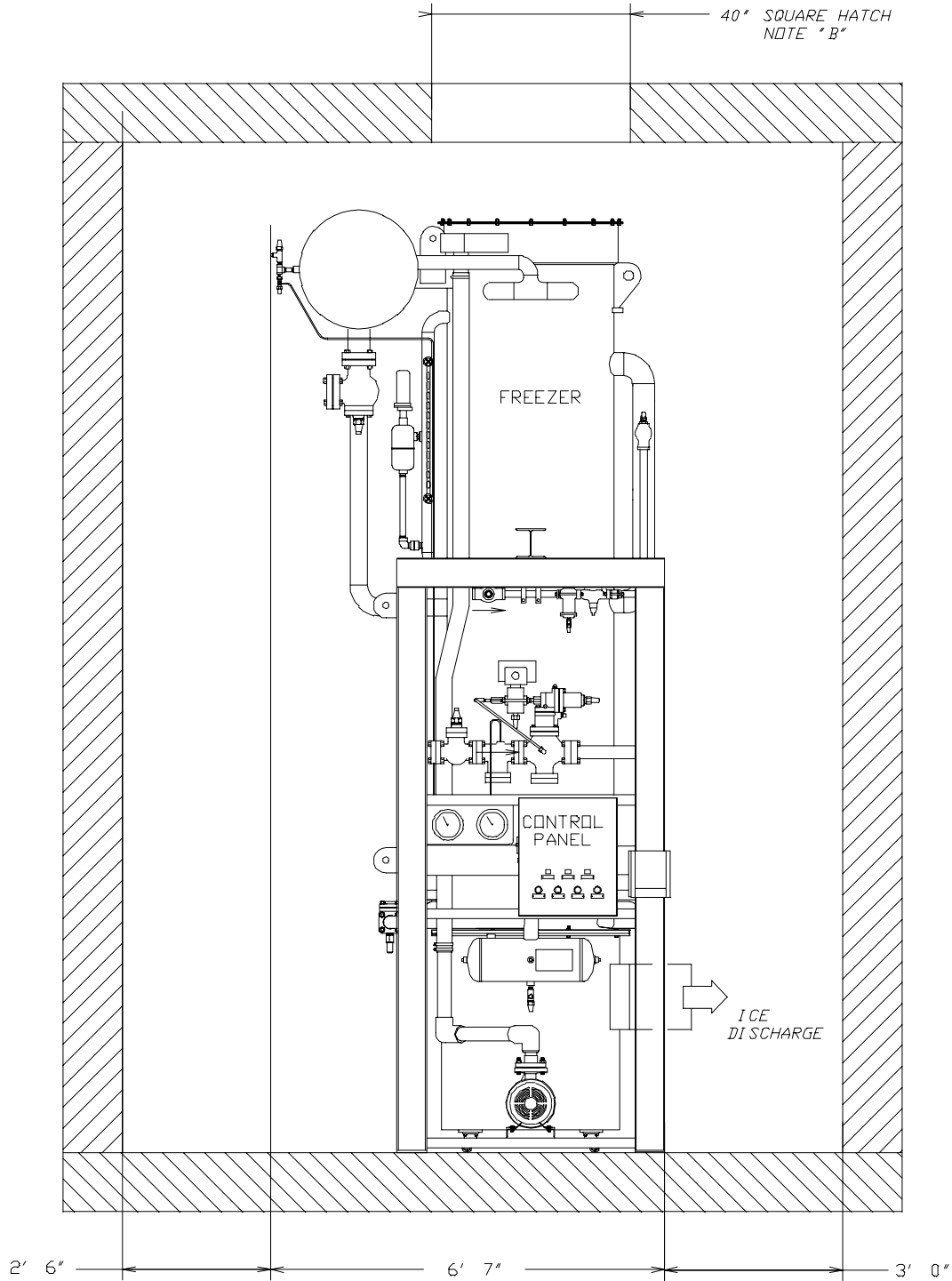

NOTES-

- A. REQUIRED TO SERVICE ELECTRICAL CONTROLS AND CUTTER ASSEMBLY.
- B. REQUIRED ABOVE FREEZER TO SERVICE FREEZER TUBES.
- C. MACHINE SHOWN WITH STD. SUPPORT, INCREASE AS REQUIRED TO ACCOMMODATE EXTENDED BASE, IF USED.

CUSTOMER NOTE: THIS DRAWING IS INTENDED TO BE USED AS A GUIDE ONLY FOR MINIMUM SPACE REQUIREMENT FOR SERVICING AND OPERATING A P34AL TUBE-ICE MACHINE. SPACE REQUIREMENTS FOR OTHER EQUIPMENT SUCH AS CONVEYORS, AUGERS, ETC. MUST BE CONSIDERED.

FIGURE 3-3A
P34AL Space Diagram (Front View)

INSTALLING YOUR TUBE-ICE MACHINE

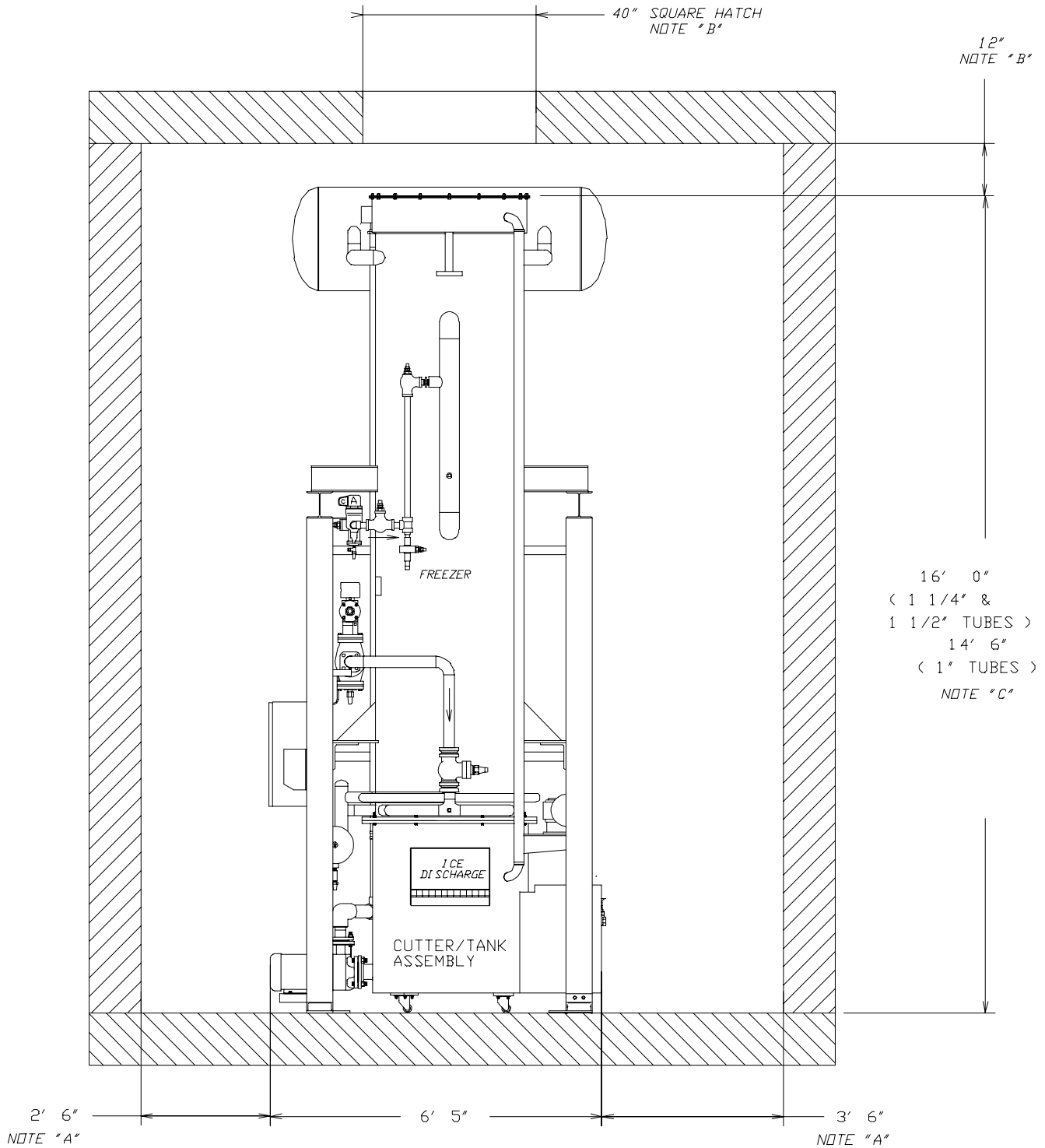

NOTES-

- A. REQUIRED TO SERVICE ELECTRICAL CONTROLS AND CUTTER ASSEMBLY.
- B. REQUIRED ABOVE FREEZER TO SERVICE FREEZER TUBES.
- C. MACHINE SHOWN WITH STD. SUPPORT, INCREASE AS REQUIRED TO ACCOMMODATE EXTENDED BASE, IF USED.

CUSTOMER NOTE: THIS DRAWING IS INTENDED TO BE USED AS A GUIDE ONLY FOR MINIMUM SPACE REQUIREMENT FOR SERVICING AND OPERATING A P34AL TUBE-ICE MACHINE. SPACE REQUIREMENTS FOR OTHER EQUIPMENT SUCH AS CONVEYORS, AUGERS, ETC. MUST BE CONSIDERED.

FIGURE 3-3B
P34AL Space Diagram (Side View)

INSTALLING YOUR TUBE-ICE MACHINE

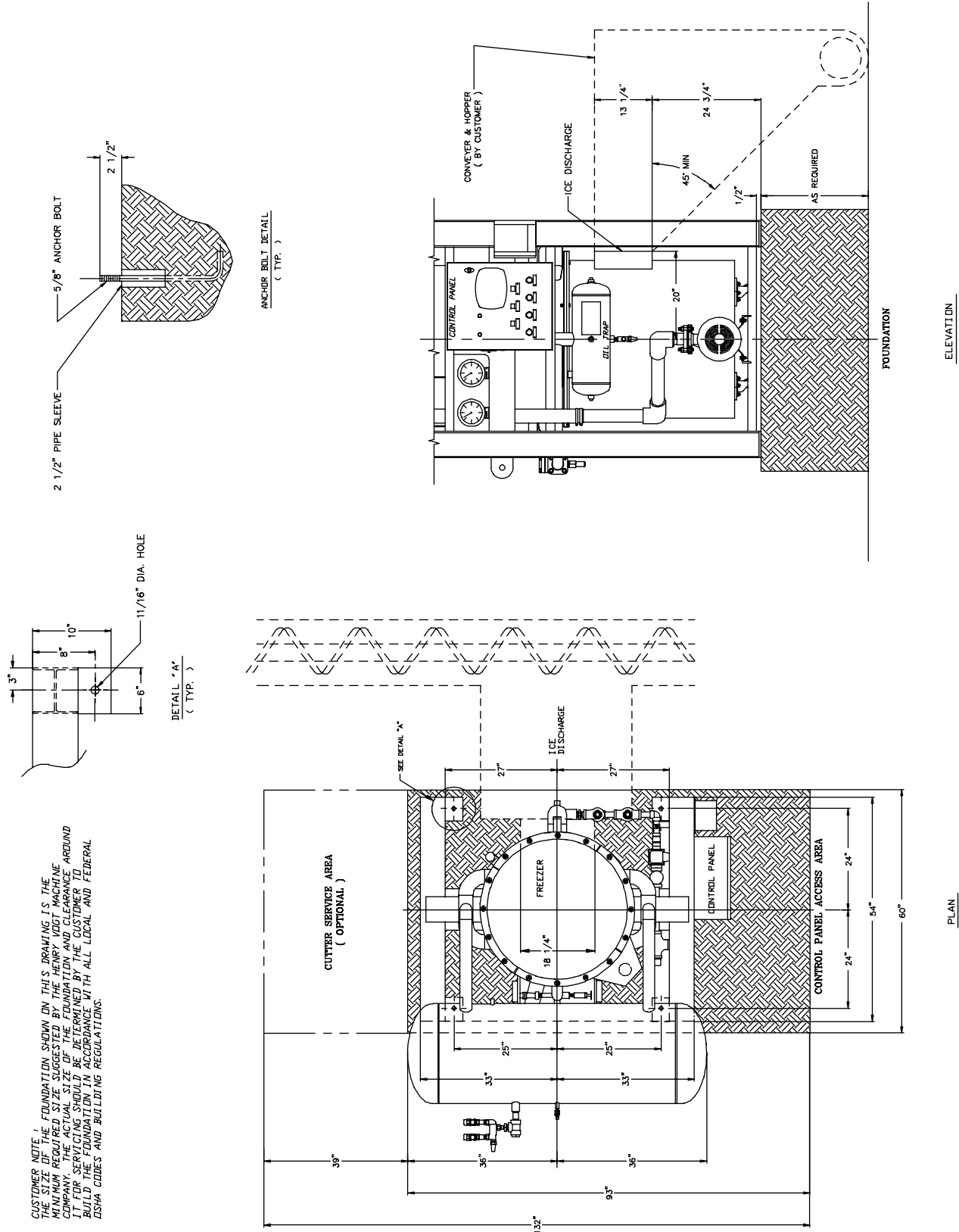

FIGURE 3-4
P34AL Foundation Layout

INSTALLING YOUR TUBE-ICE MACHINE

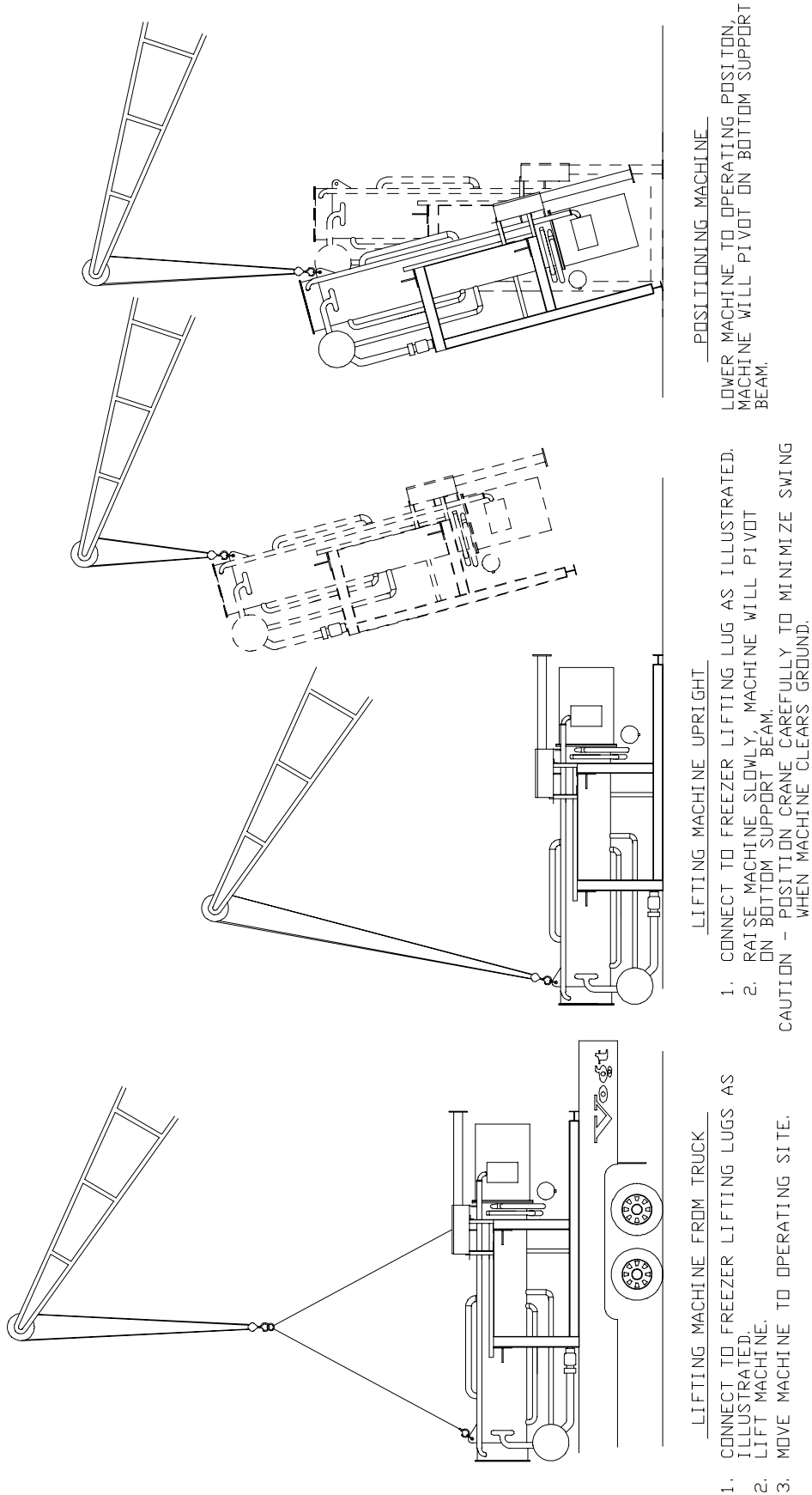

FIGURE 3-5
Lifting Procedure for P24AL

INSTALLING YOUR TUBE-ICE MACHINE

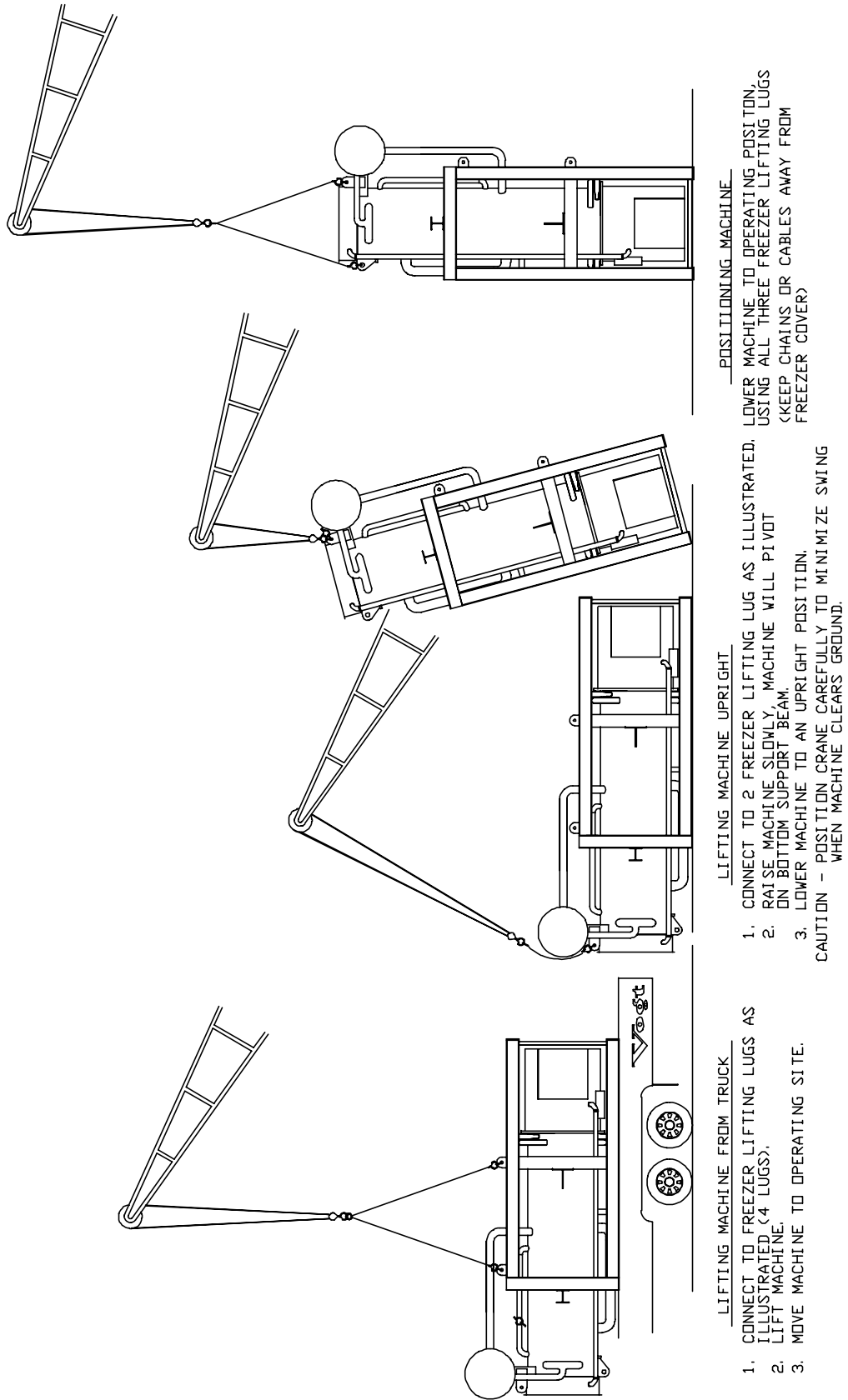
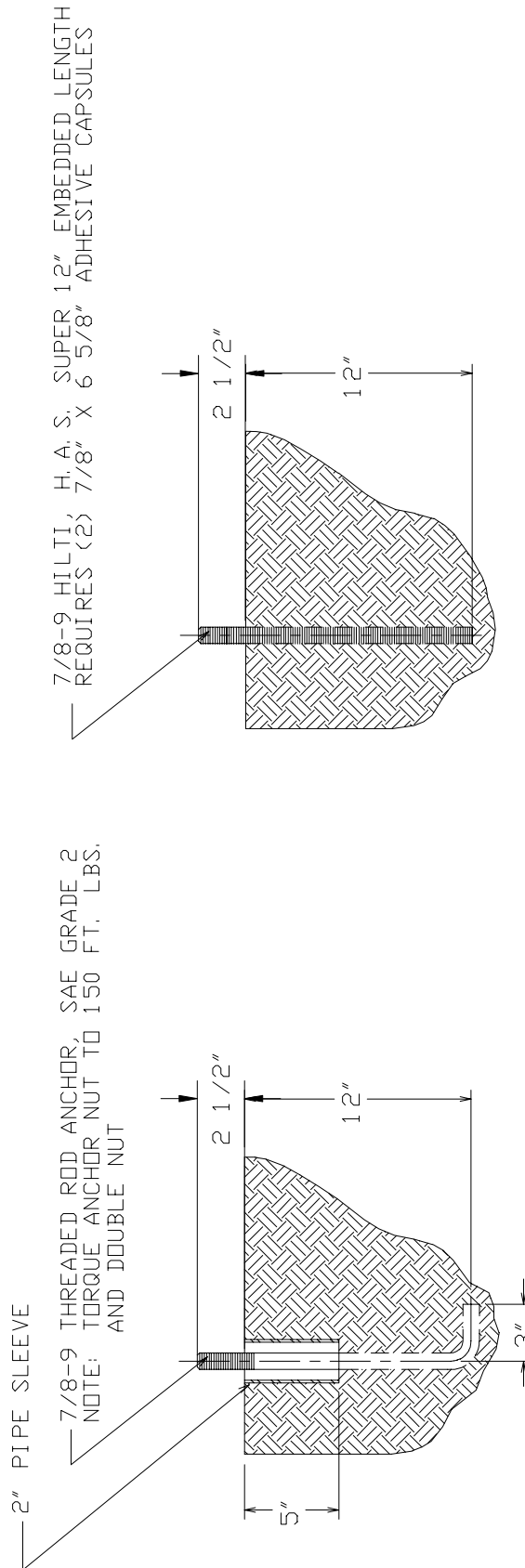

FIGURE 3-6
Lifting Procedure for P34AL

INSTALLING YOUR TUBE-ICE MACHINE



HILTI H. V. A. ADHESIVE SYSTEM BULLETIN 4. 3. 1

FIGURE 3-6
Seismic Anchoring Detail for P24AL and P34AL Tube-Ice Machines

Piping and Drain Connections. See Figure 1-1 to 1-8 and 3-11 to 3-17 for connection locations.

When connecting refrigeration piping, you must follow and adhere to all ANSI/ASHRAE 15 “Safety Code for Mechanical Refrigeration” and ANSI Standard B-31.5 “Refrigeration Piping Code”. Also, all piping must conform to all state and local codes. Make sure all piping is kept clean, dry and contaminate free. All piping should be supported properly.

! CAUTION !
Exterior shut-off valves must be provided in the water inlet lines. The minimum inlet water pressure for satisfactory operation of the machine is 40 psig. The maximum allowable pressure is 100 psig.
! CAUTION !

Model	Make-up Water In	Flushing Water In	Water Tank Drain	Water Tank Overflow	Low Side Suction Connection*	Low Side Liquid Connection**	Low Side Thaw Gas Connection
P24A	3/4" FPT	3/4" FPT 72 gal/3 min.	2" FPT	3" FPT	3" Flange	3/4" FPT or SW	2" Flange
P34A	1" FPT	3/4" FPT 104 gal/3 min.	2" FPT	3" FPT	4" Flange	1" FPT or SW	2" Flange

* Mating 4 bolt flange supplied with machine.

** Liquid connection is all purpose coupling.

TABLE 3-1
Water Supply, Drain and Refrigeration Connections
(See FIGURE 1-1 through 1-8 for locations)

Make-Up Water In. The water required for ice making must be potable water, safe for human consumption, and should be of the highest quality available. The best way to determine water quality is to have a complete water quality analysis by a qualified laboratory.

It is advisable to install a particle filter in the make-up and flushing water lines to trap dirt, sand, rust, or other solid particles prior to entering the water tank and contaminating the ice. Be sure to size the filter large enough to meet the water demands of 15 GPM (peak flow), allowing for a restriction through the filter as it traps these particles. The inlet water pressure should be a minimum of 40 psi. Refer to TABLE 3-1 for line size and Section 11 for average flow rate at various water temperatures.

Flushing Water In. Flushing water (blowdown) is necessary to melt ice fines and flush dissolved solids from the water tank during the thawing (harvest) cycle. This function is important and helps to maintain good ice quality. If water quality is superior, this blowdown can be reduced by installing a smaller orifice in the flushing outlet elbow. Make sure there is enough flushing water to prevent the accumulation of excessive ice fines in the tank.

If make-up and flushing water are from the same source, they can be connected by a common line to the machine.

INSTALLING YOUR TUBE-ICE MACHINE

Water Tank Drain. This valve and connection is for the purpose of flushing and draining the water tank of impurities, foreign material and cleaning chemicals used during servicing. It should be piped to an open drain or sump for visible discharge. It can be tied in with the overflow line but no others.

Water Tank Overflow. A 3" FPT connection on the side of the water tank is provided to carry away overflow water during the thawing (harvest cycle). This water contains ice fines accumulated during harvesting and dissolved solids accumulated during the freezing cycle. **Do not reduce the size of this line.** Three inches is needed to provide sufficient area for ice fines to be flushed out, especially if the incoming flushing water is 55°F (13°C) or below. This overflow line should not tie in with any other drain line except the water tank drain.

Unless water quality is superior, do not discharge the overflow water to the cooling tower system. This water contains additional dissolved solids left from the ice making process and can lead to excessive condenser fouling or cooling tower chemical usage. It is recommended that a heat exchanger be used in place of direct contact with condenser water.

Receiver. The receiver used to supply hot thaw gas must be sized adequately to provide sufficient thaw gas. Table 3-2 shows the volume required to hold the refrigeration charge of the freezer and the hot gas required for the thaw cycle. It is recommended that a heating coil be installed in the receiver to assure that the liquid ammonia is at saturated temperature at the start of each thaw period.

Note: Additional storage volume may be required for the interconnecting piping. Add volume of interconnecting piping to the values shown in Table 3-2

RECEIVER VOLUME (Cubic Feet)		
MODEL	With Heating Coil	With out Heating Coil
P24AL	30	45
P34AL	50	70

TABLE 3-2
Receiver Volume Requirements

Thaw Gas Pressure Regulator. The thaw gas pressure regulator is a 2" solinoid operated pressure combination regulator and shut-off valve (see figures 1-2 and 1-5 for locations). **Do not reduce the size of this line.** This valve is deigned to carry the proper amount of thaw gas to the evaporator during the harvest cycle. See section 5-7 for operating instuctions.

Suction Pressure Regulator. When a P24AL or P34AL is attached to a central system a pressure regulator will be required (see Figures 3-15 through 3-16 for location). This regulator (usually furnished by the purchaser) must be a combination back pressure regulating and stop type valve. The usual minimum pressure drop across this type valve is 2 psig, therefore the valve must be set to maintain a freezer pressure at least 2 psi above the maximum general suction pressure.

Compressor Unloading. When a P24AL or P34AL is attached to a dedicated compressor system unloading of the compressor will be required. A minimum compressor unloading during the harvest cycle is 50%. If the compressor can not be unloaded then a hot gas bypass to the suction line must be installed. See Figures 3-13 through 3-16.

INSTALLING YOUR TUBE-ICE MACHINE

Cooling Tower (optional). When selecting a cooling tower, careful attention must be given to operating wet bulb conditions. It is advisable to check with your local cooling tower distributor for their recommendations based on actual operating conditions in your area. An average wet bulb of 78°F is typical in the U.S., but many localities have designed wet bulbs as low as 72°F or as high as 82°F.

The cooling tower water pump must be capable of delivering the required volume of water through the condenser. Due to cooling tower location and pressure drop through water lines and regulating valves, the water pump must be sized for each installation. Table 3-2 shows the total heat rejection, in 1000 BTU's per hour for the P24AL and P34AL at different suction temperatures. The water piping for the cooling tower and the installation of the pump must be in accordance with the manufacturer's instructions. Caution must be used to prevent the condenser water pump from losing it's prime during off cycles.

Proper water treatment for the prevention of mineral and foreign matter accumulation in the condenser or cooling tower is recommended. A water analysis should be obtained to determine the proper chemicals to use. The use of a 40 mesh strainer in the condenser water supply line is also recommended.

Suction Temperature °F / °C	P24AL - Cylinder			P34AL - Cylinder		
	1" Tube	1 1/4" Tube	1 1/2" Tube	1" Tube	1 1/4" Tube	1 1/2" Tube
21.4 /-6.0	554	512	353	1135	1051	737
16.6 /-8.5	919	853	596	1850	1724	1234
11.3 /-11.5	1420	1324	941	2809	2637	1930
5.5 /-15.7	2120	1987	1440	4121	3901	2926
-1.0 /-18.3	3157	2981	2209	6027	5767	4440
Suction Temperature °F / °C	P24AL - Crushed			P34AL - Crushed		
	1" Tube	1 1/4" Tube	1 1/2" Tube	1" Tube	1 1/4" Tube	1 1/2" Tube
21.4 /-6.0	722	779	685	1446	1540	1374
16.6 /-8.5	1167	1247	1113	2282	2412	2189
11.3 /-11.5	1754	1858	1685	3356	3522	3248
5.5 /-15.7	2542	2674	2462	4769	4982	4664
-1.0 /-18.3	3668	3840	3589	6758	7040	6685

Total Heat Rejection is based on pulldown of 105°F SDT and are nominal values based on open drive reciprocating compressor.

Consult factory for condenser sizing if desired.

TABLE 3-3
Total Heat Rejection (MBH)

The condenser water pump should be sized on GPM required for condenser at 80 ft. total discharge head for a typical installation. However, due to cooling tower location and pressure drop through water lines, the water pump should be sized for each installation.

INSTALLING YOUR TUBE-ICE MACHINE

If the condenser inlet water temperature is expected to be below 75°F/24°C, a water regulating valve should be installed in the condenser water inlet line and adjusted to maintain a head pressure of not less than 175 psig.

See FIGURES 3-5 through 3-8 for possible cold climate installations with indoor sump.

Safety Valves. Two safety pressure relief valves are an integral part of the packaged Tube-Ice[®] machine. They are located on the suction accumulator of the freezer. Vent each of the pressure relief valves to the atmosphere in such a manner as to comply with local and national codes. Refer to the International Institute of Ammonia Refrigeration (IIAR) standard for specific requirements and instructions.

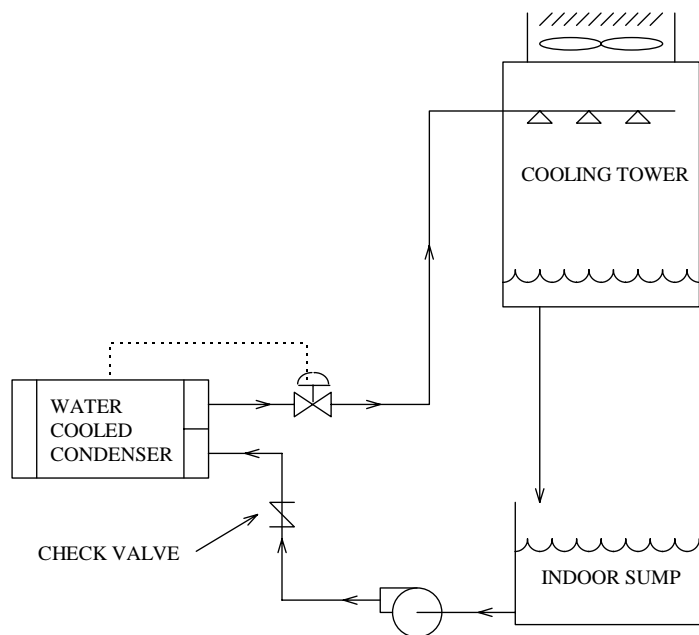

FIGURE 3-8
1 PUMP/2-WAY VALVE
*** Poor Freeze Protection**

Because low flow rate = high freeze chance

INSTALLING YOUR TUBE-ICE MACHINE

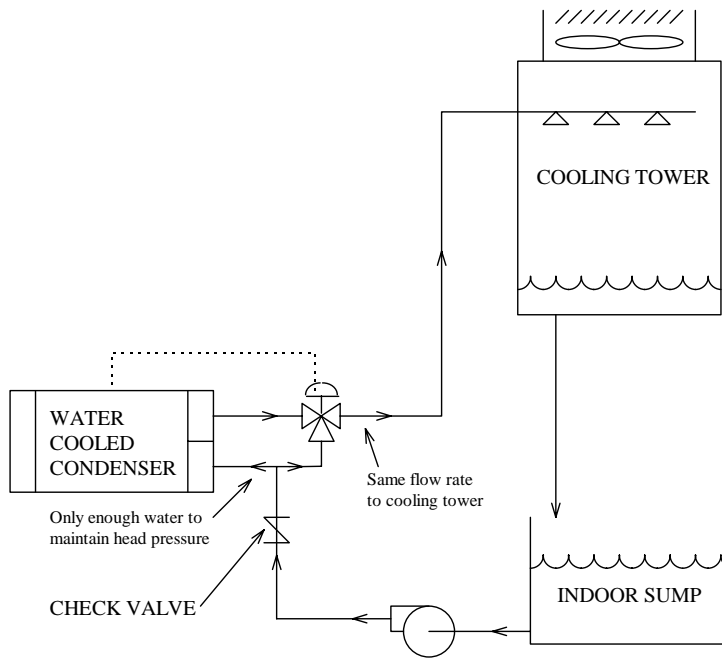

FIGURE 3-9
1 PUMP/3-WAY VALVE
*** Better Freeze Protection**

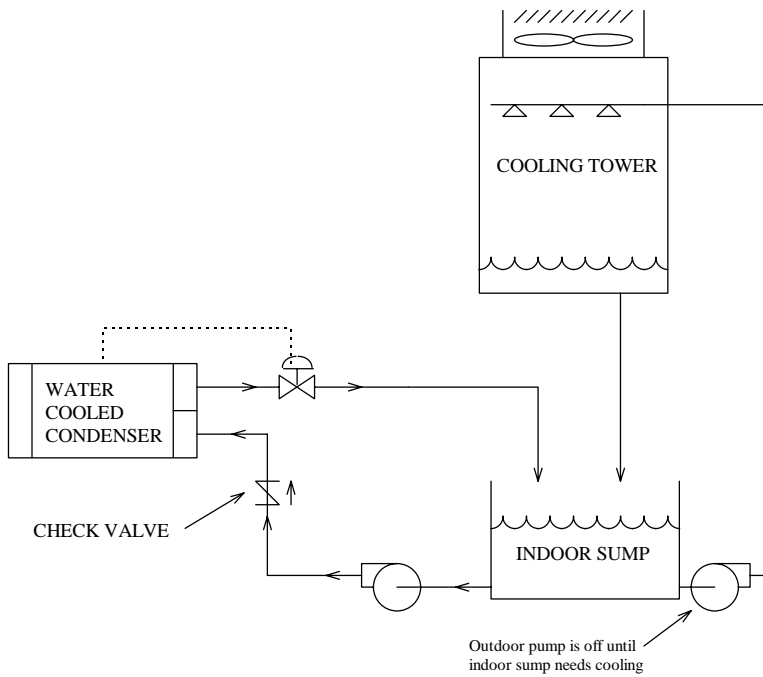

FIGURE 3-10
2 PUMP/2-WAY VALVE
*** Best Freeze Protection**

INSTALLING YOUR TUBE-ICE MACHINE

Wiring and Electrical Connections.

! WARNING !
Only service personnel experienced in refrigeration and qualified to work with high voltage electrical equipment should be allowed to install or work with the Tube-Ice[®] machine.
! WARNING !

A fused disconnect must be provided near the Tube-Ice[®] machine. The control panel and transformer (if required) are attached to the structurals on the front of the Tube-Ice[®] machine (see FIGURE 3-11). Incoming 3 phase power will be connected at the cutter motor circuit breaker (CB3). Terminals L1, L2, L3 for operation of the Tube-Ice[®] machine and its controls. Rotation checking of the, cutter motor, and water pump and auxiliary equipment is required (see rotation check). Also, if one leg of the 3 phase power is higher or lower (“wild”), then it should be connected to terminal L3. Connect the ground wire to the “ground” terminal provided.

Make sure wires #22 and #27 are connected to the elapse time (ET) indicator in the control panel.

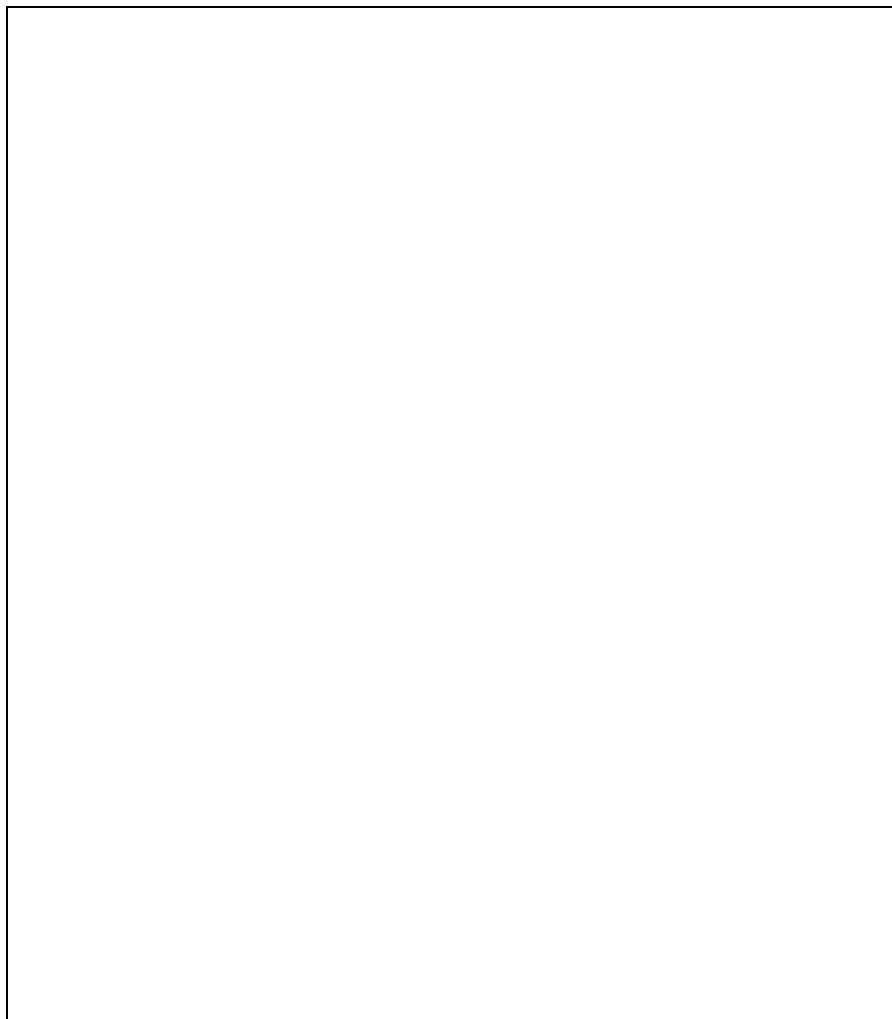

FIGURE 3-12
Power Supply Connections

INSTALLING YOUR TUBE-ICE MACHINE

Voltage Unbalance Voltage unbalance can cause motors to overheat and fail. Voltage imbalance between any two legs should be no greater than 2%.

Example: Supply voltage = 230-3-60

Voltage Readings: AB = 220 Volts
BC = 225 Volts Average = $(220 + 225 + 227)/3 = 224$ Volts
AC = 227 Volts

(AB) $224 - 220 = 4$ Volts (Highest Deviation)

(BC) $225 - 224 = 1$ Volts

(AC) $227 - 224 = 3$ Volts

% Voltage Unbalance = $100 \times (4/224) = 1.78\%$ "Acceptable"

Important: If the supply voltage phase unbalance is more the 2%, contact your local electric utility company.

Current Unbalance Voltage unbalance will cause a current unbalance, but a current unbalance does not necessarily mean that a voltage unbalance exists. A loose terminal connection or a buildup of dirt or carbon on one set of contacts would cause a higher resistance on that leg than on the other two legs. Current follows the path of least resistance, therefore if terminal connection L1 is loose or dirty, L2 and/or L3 will have higher current.

Higher current causes more heat to be generated in the motor windings. The maximum acceptable current unbalance is 10%.

Example:

Current Readings: L1 = 96 Amps
L2 = 91 Amps Average = $(96 + 91 + 98)/3 = 95$ Amps
L3 = 98 Amps

(L1) $96 - 95 = 1$ Amps

(L2) $95 - 91 = 4$ Amps (Highest Deviation)

(L3) $98 - 95 = 3$ Amps

% Current Unbalance = $100 \times (4/95) = 4.2\%$ "Acceptable"

Rotation Check. The compressor, cutter, and pump motor rotation are factory synchronized, but must be checked at installation. For cylinder ice production, the cutter disc as viewed at the ice discharge opening should turn from left to right.

Check rotation by the following procedure:

1. Turn the power to the machine on and check voltages.
2. Make sure the water tank is full of clean water.
3. Turn the Hand-Auto switch (ISS) to HAND position. The water pump will start and the freezing (1LT) and the liquid feed (2LT) pilot lights will illuminate. Check pump rotation.

INSTALLING YOUR TUBE-ICE MACHINE

4. Push the MANUAL HARVEST button. The water pump will stop, the “Freezing and Liquid Feed” lights will go out, and after 20-30 seconds, the cutter motor will start. The thawing gas solenoid valve will open and the “Thawing” pilot light (3LT) will illuminate.
5. Check the cutter disc rotation. It should be turning from left to right (CCW looking from the top).
6. Turn the HAND-AUTO switch to AUTO to stop the cutter.

To change rotation, follow this procedure:

1. Disconnect power to the machine and lock it out to make sure it can't be turned back on.
2. Check for power at L1, L2, L3 with a volt meter to make sure it is off.
3. At the cutter motor circuit breaker (CB3) or at the power disconnect, reverse wires L1 and L2.
4. Make sure these terminals are tight and restore power to the machine.
5. Perform rotation check again to confirm that it is correct.

! CAUTION !
Do not attempt to start the machine until first making sure all conditions listed in the Installation Review Checklist and all necessary valves have been opened for operation.
! CAUTION !

Auxiliary Controls or Equipment. When connecting other equipment such as high/low pressure swith, conveyor motors, bin level control, etc., refer to the control panel wiring drawing for the proper connecting terminals and instructions. See Figure 6-3.

INSTALLING YOUR TUBE-ICE MACHINE

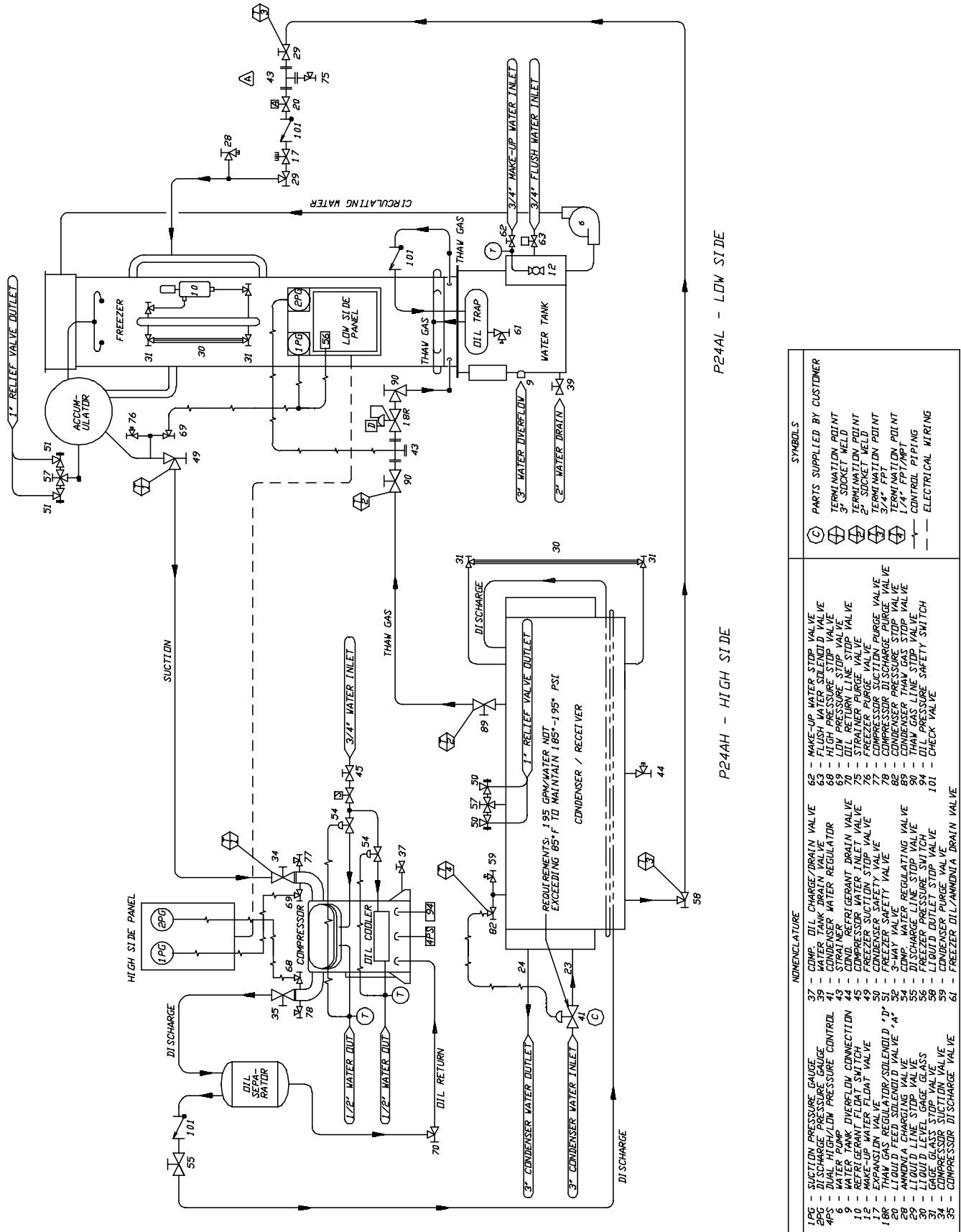
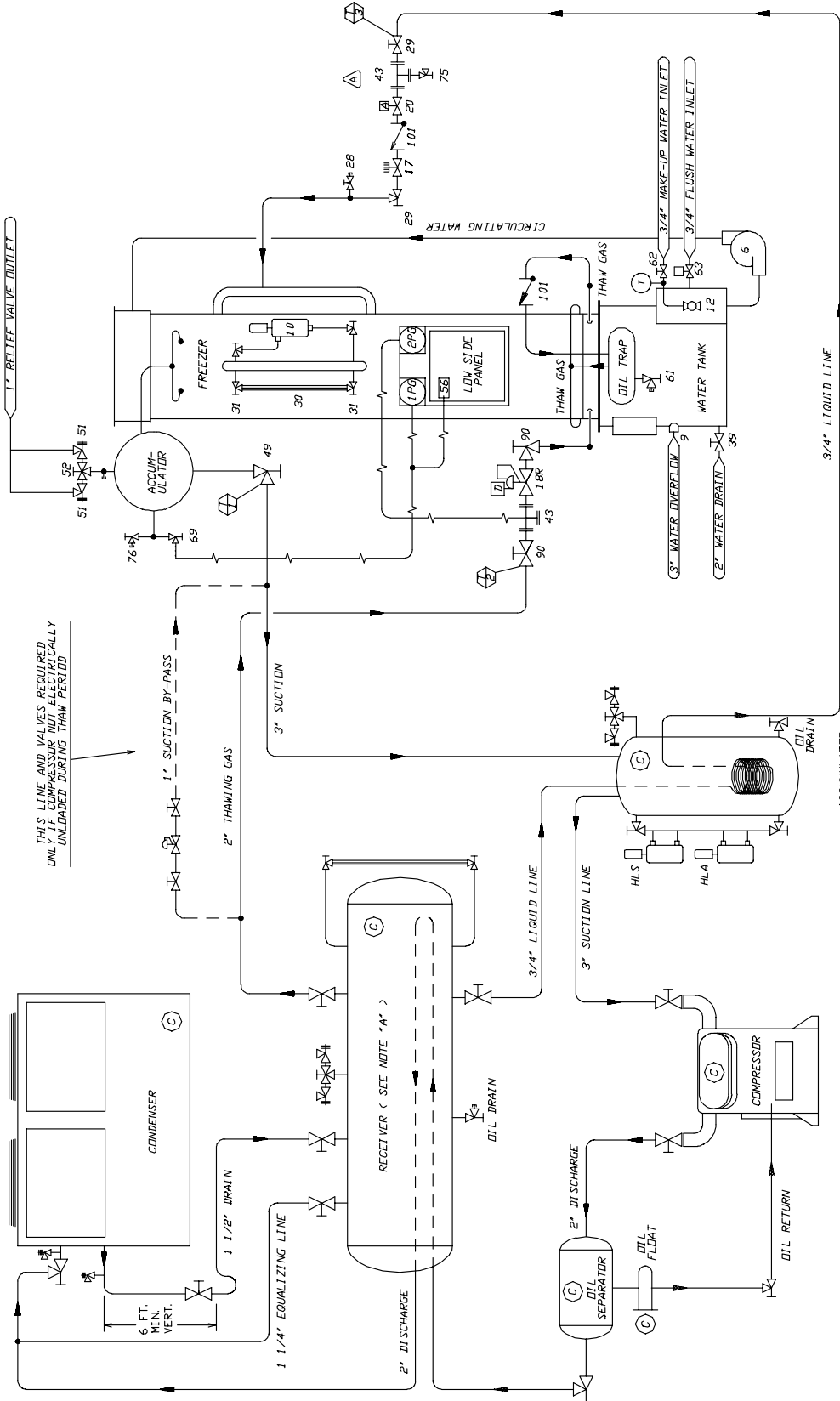

FIGURE 3-12
Interconnecting Piping for Vogt P24AL and Vogt 24AHS

NOMENCLATURE		SYMBOLS	
1 PG	SUCTION PRESSURE GAUGE	(C)	PARTS SUPPLIED BY CUSTOMER
2 PG	DISCHARGE PRESSURE GAUGE	(T)	TERMINATION POINT
3 PG	WATER TANK OVERFLOW	(S)	3" SOCKET WELD
4 PG	WATER TANK DRAIN	(F)	5" SOCKET WELD
5	WATER PUMP	(P)	3/4" FPT
6	WATER TANK OVERFLOW CONNECTION	(M)	TERMINATION POINT
9	REFRIGERANT FLOOD SWITCH	(R)	TERMINATION POINT
10	REFRIGERANT WATER INLET VALVE	(W)	1/4" FPT/MPT
11	REFRIGERANT WATER STOP VALVE	(E)	CONTROL PIPING
12	REFRIGERANT WATER PURGE VALVE	(D)	ELECTRICAL WIRING
13	REFRIGERANT WATER STOP VALVE		
14	REFRIGERANT WATER PURGE VALVE		
15	REFRIGERANT WATER STOP VALVE		
16	REFRIGERANT WATER PURGE VALVE		
17	REFRIGERANT WATER STOP VALVE		
18	REFRIGERANT WATER PURGE VALVE		
19	REFRIGERANT WATER STOP VALVE		
20	REFRIGERANT WATER PURGE VALVE		
21	REFRIGERANT WATER STOP VALVE		
22	REFRIGERANT WATER PURGE VALVE		
23	REFRIGERANT WATER STOP VALVE		
24	REFRIGERANT WATER PURGE VALVE		
25	REFRIGERANT WATER STOP VALVE		
26	REFRIGERANT WATER PURGE VALVE		
27	REFRIGERANT WATER STOP VALVE		
28	REFRIGERANT WATER PURGE VALVE		
29	REFRIGERANT WATER STOP VALVE		
30	REFRIGERANT WATER PURGE VALVE		
31	REFRIGERANT WATER STOP VALVE		
32	REFRIGERANT WATER PURGE VALVE		
33	REFRIGERANT WATER STOP VALVE		
34	REFRIGERANT WATER PURGE VALVE		
35	REFRIGERANT WATER STOP VALVE		
36	REFRIGERANT WATER PURGE VALVE		
37	COMP. DIL. CHARGE DRAIN VALVE		
38	CONDENSER DRAIN VALVE		
39	CONDENSER WATER REGULATOR		
40	STRAINER		
41	CONDENSER WATER REGULATOR		
42	CONDENSER WATER PURGE VALVE		
43	CONDENSER WATER STOP VALVE		
44	COND. REFRIGERANT DRAIN VALVE		
45	COND. REFRIGERANT WATER INLET VALVE		
46	COND. REFRIGERANT WATER STOP VALVE		
47	COND. REFRIGERANT WATER PURGE VALVE		
48	COND. REFRIGERANT WATER STOP VALVE		
49	COND. REFRIGERANT WATER PURGE VALVE		
50	COND. REFRIGERANT WATER STOP VALVE		
51	COND. REFRIGERANT WATER PURGE VALVE		
52	COND. REFRIGERANT WATER STOP VALVE		
53	COND. REFRIGERANT WATER PURGE VALVE		
54	COND. REFRIGERANT WATER STOP VALVE		
55	COND. REFRIGERANT WATER PURGE VALVE		
56	COND. REFRIGERANT WATER STOP VALVE		
57	COND. REFRIGERANT WATER PURGE VALVE		
58	COND. REFRIGERANT WATER STOP VALVE		
59	COND. REFRIGERANT WATER PURGE VALVE		
60	COND. REFRIGERANT WATER STOP VALVE		
61	COND. REFRIGERANT WATER PURGE VALVE		
62	COND. REFRIGERANT WATER STOP VALVE		
63	COND. REFRIGERANT WATER PURGE VALVE		
64	COND. REFRIGERANT WATER STOP VALVE		
65	COND. REFRIGERANT WATER PURGE VALVE		
66	COND. REFRIGERANT WATER STOP VALVE		
67	COND. REFRIGERANT WATER PURGE VALVE		
68	COND. REFRIGERANT WATER STOP VALVE		
69	COND. REFRIGERANT WATER PURGE VALVE		
70	COND. REFRIGERANT WATER STOP VALVE		
71	COND. REFRIGERANT WATER PURGE VALVE		
72	COND. REFRIGERANT WATER STOP VALVE		
73	COND. REFRIGERANT WATER PURGE VALVE		
74	COND. REFRIGERANT WATER STOP VALVE		
75	COND. REFRIGERANT WATER PURGE VALVE		
76	COND. REFRIGERANT WATER STOP VALVE		
77	COND. REFRIGERANT WATER PURGE VALVE		
78	COND. REFRIGERANT WATER STOP VALVE		
79	COND. REFRIGERANT WATER PURGE VALVE		
80	COND. REFRIGERANT WATER STOP VALVE		
81	COND. REFRIGERANT WATER PURGE VALVE		
82	COND. REFRIGERANT WATER STOP VALVE		
83	COND. REFRIGERANT WATER PURGE VALVE		
84	COND. REFRIGERANT WATER STOP VALVE		
85	COND. REFRIGERANT WATER PURGE VALVE		
86	COND. REFRIGERANT WATER STOP VALVE		
87	COND. REFRIGERANT WATER PURGE VALVE		
88	COND. REFRIGERANT WATER STOP VALVE		
89	COND. REFRIGERANT WATER PURGE VALVE		
90	COND. REFRIGERANT WATER STOP VALVE		
91	COND. REFRIGERANT WATER PURGE VALVE		
92	COND. REFRIGERANT WATER STOP VALVE		
93	COND. REFRIGERANT WATER PURGE VALVE		
94	COND. REFRIGERANT WATER STOP VALVE		
95	COND. REFRIGERANT WATER PURGE VALVE		
96	COND. REFRIGERANT WATER STOP VALVE		
97	COND. REFRIGERANT WATER PURGE VALVE		
98	COND. REFRIGERANT WATER STOP VALVE		
99	COND. REFRIGERANT WATER PURGE VALVE		
100	COND. REFRIGERANT WATER STOP VALVE		
101	COND. REFRIGERANT WATER PURGE VALVE		

INSTALLING YOUR TUBE-ICE MACHINE



NOTE: THIS DRAWING IS FOR REFERENCE ONLY. IT IS NOT INTENDED TO BE USED FOR CONSTRUCTION OR INSTALLATION PURPOSES. THE INSTALLER SHALL BE RESPONSIBLE FOR THE LOCATION, POSITION, SIZE, SELECTION AND LOCATION OF SERVICE, CONTROL, RELIEF VALVES, AND RELATED PIPING ARE THE RESPONSIBILITY OF THE INSTALLER OR OTHERS. THE HENRY VOGT MACHINE COMPANY IS NOT PROVIDED BY OTHERS.

THIS LINE AND VALVES REQUIRED ONLY IF COMPRESSOR NOT ELECTRICALLY UNLOADED DURING THAW PERIOD

NOTE 'A'

RECEIVER REQUIREMENTS		
30	CUBIC FEET	MINIMUM WITH HEATING COIL
45	CUBIC FEET	MINIMUM WITH OUT HEATING COIL
HEATING COIL RECOMMENDED TO ASSURE THAT COIL REMAINS FULLY SUBMERGED THROUGHOUT ENTIRE THAW PERIOD.		
APPROX. TOTAL AMMONIA CHARGE IS 1000 LBS. USE 30" F SUCTION AND 100" F DISCHARGE WHEN SIZING CONDENSER.		

SYMBOLS		
(C)	PARTS SUPPLIED BY CUSTOMER	
(T)	TERMINATION POINT	
(S)	9" SOCKET WELD	
(P)	TERMINATION POINT	
(D)	TERMINATION POINT	
(V)	3/4" MPT	
(H)	VALVES SHOWN SHARDED, INSTALLED AT FACTORY. ALL OTHER VALVES ARE SUPPLIED BY CUSTOMER.	

NOMENCLATURE		
49	FREZZER SUCTION STOP VALVE	
50	3-WAY VALVE	
52	FREZZER PRESSURE SWITCH	
56	FRZR. DIL/AMMONIA DRAIN VALVE	
61	FRZR. DIL/AMMONIA DRAIN VALVE	
62	MAKE-UP WATER STOP VALVE	
69	LOW PRESSURE STOP VALVE	
75	STRAINER PURGE VALVE	
76	FREZZER PURGE VALVE	
90	THAW GAS LINE STOP VALVE	
91	THAW GAS LINE STOP VALVE	
94	HIGH LEVEL ALARM	
HLS	HIGH LEVEL SHUT-OFF	
T	THERMOMETER	

1PG	SUCTION PRESSURE GAUGE
EPG	REFRIGERANT PRESSURE GAUGE
9	WATER PUMP
9	WATER TANK DIVERFLOM CONNECTION
10	REFRIGERANT FLOD/AT SWITCH
12	MAKE-UP WATER FLOD/AT VALVE
1BR	THAW GAS REGULATOR/SOLENOID 'D'
20	LIQUID FEED SOLENOID VALVE 'A'
28	AMMONIA CHARGING VALVE
29	LIQUID LINE STOP VALVE
30	LIQUID LINE STOP VALVE
39	GAGE GLASS STOP VALVE
43	WATER TANK DRAIN VALVE
43	STRAINER

FIGURE 3-13
Interconnecting Piping for Vogt P24AL and Dedicated High Side

INSTALLING YOUR TUBE-ICE MACHINE

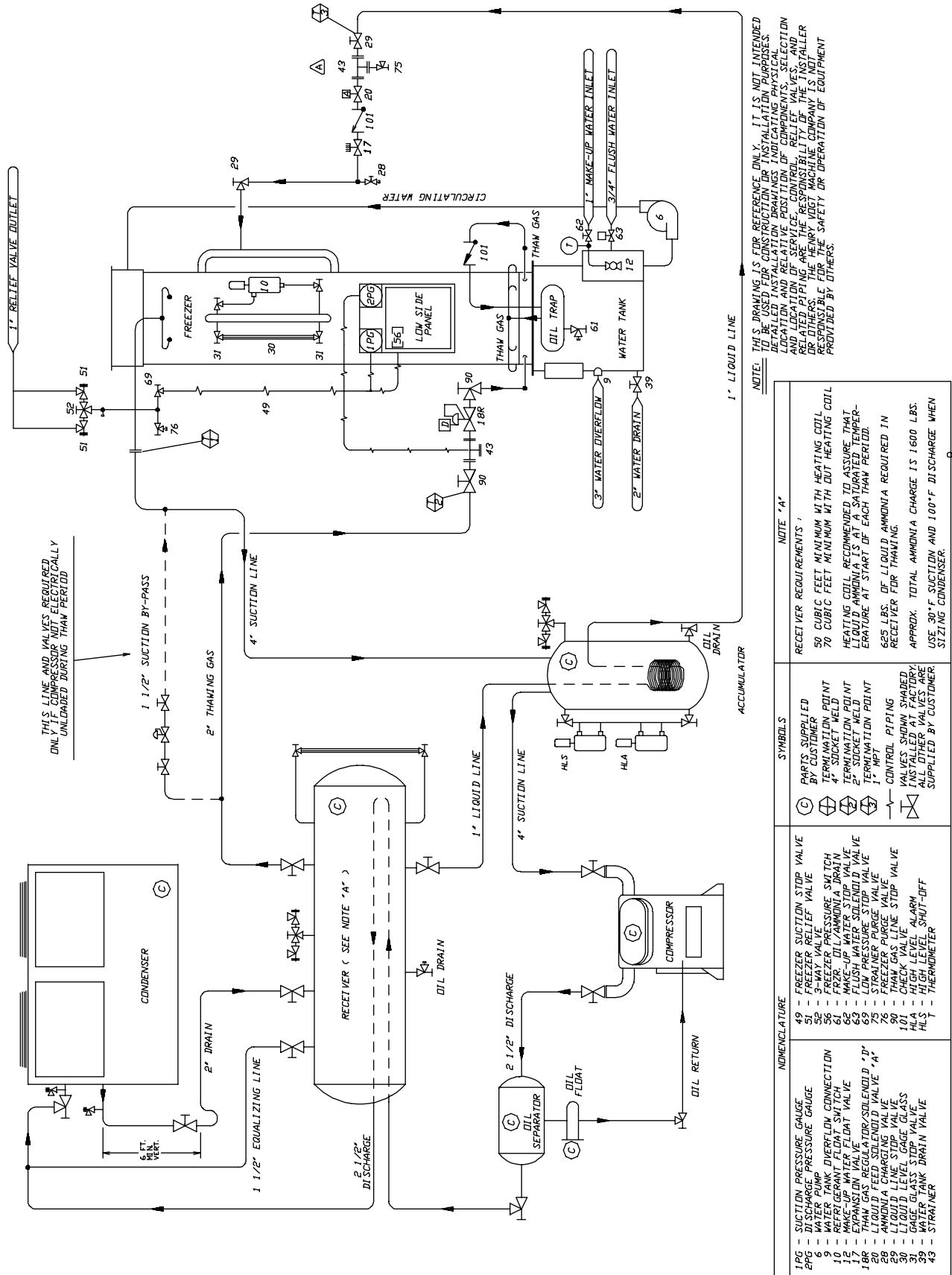
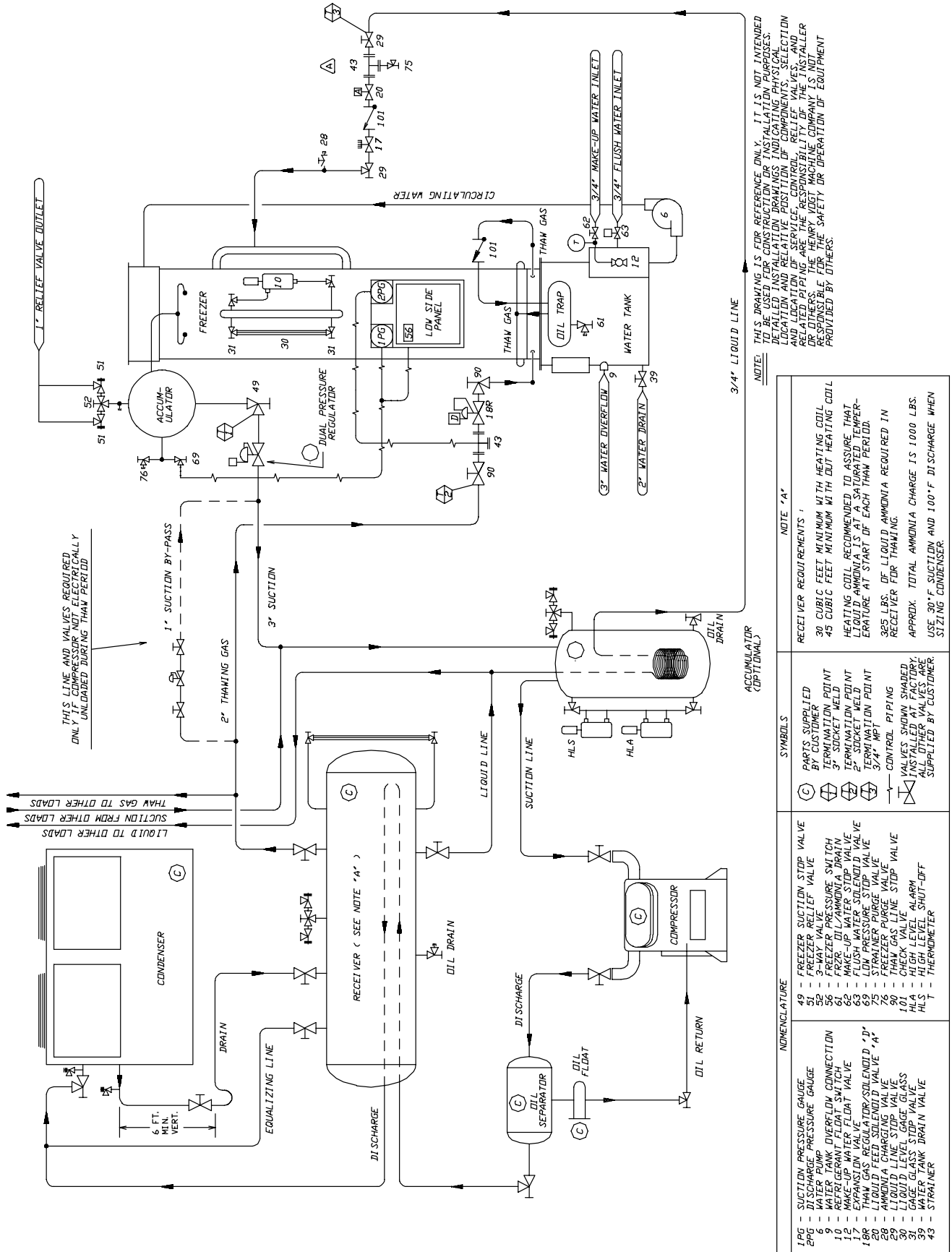

FIGURE 3-14
Interconnecting Piping for Vogt P34AL and Dedicated High Side

INSTALLING YOUR TUBE-ICE MACHINE



NOTE: THIS DRAWING IS FOR REFERENCE ONLY. IT IS NOT INTENDED TO BE USED FOR CONSTRUCTION OR INSTALLATION PURPOSES. LOCATION AND RELATIVE POSITION OF COMPONENTS, SELECTION AND LOCATION OF SERVICE, CONTROL, RELIEF VALVES, AND RELATED PIPING ARE THE RESPONSIBILITY OF THE INSTALLER OR SERVICE PERSONNEL. THE MANUFACTURER'S INSTRUCTIONS AND SAFETY INFORMATION SHOULD BE READ AND OBSERVED AT ALL TIMES. THE SAFETY ON OPERATION OF EQUIPMENT PROVIDED BY OTHERS.

THIS LINE AND VALVES REQUIRED ONLY IF COMPRESSOR NOT ELECTRICALLY UNLOADED DURING THAW PERIOD

NOMENCLATURE	SYMBOLS	NOTE 'A'
1PG - SUCTION PRESSURE GAUGE	(C)	RECEIVER REQUIREMENTS :
EPG - WATER PUMP	(P)	30 CUBIC FEET MINIMUM WITH HEATING COIL
9 - WATER TANK OVERFLOW CONNECTION	(T)	45 CUBIC FEET MINIMUM WITH OUT HEATING COIL
10 - REFRIGERANT FLOAT SWITCH	(F)	HEATING COIL RECOMMENDED TO ASSURE THAT
15 - MAKE-UP WATER STOP VALVE	(S)	LEAKAGE AT START UP EACH THAW PERIOD.
16 - THAW GAS REGULATOR/SOLENOID 'D'	(R)	365 LBS. OF LIQUID AMMONIA REQUIRED IN
20 - LIQUID FEED SOLENOID 'D'	(D)	RECEIVER FOR THAWING.
28 - AMMONIA CHARGING VALVE	(A)	APPROX. TOTAL AMMONIA CHARGE IS 1000 LBS.
29 - LIQUID LINE STOP VALVE	(V)	USE 30°F SUCTION AND 100°F DISCHARGE WHEN
31 - GAGE GLASS STOP VALVE	(G)	SIZING CONDENSER.
39 - WATER TANK DRAIN VALVE	(D)	
43 - STRAINER	(S)	
49 - FREEZER SUCTION STOP VALVE	(F)	
56 - FREEZER RELIEF VALVE	(R)	
58 - FREEZER PRESSURE SWITCH	(P)	
61 - FRZR. DIL/AMMONIA DRAIN	(D)	
62 - MAKE-UP WATER STOP VALVE	(S)	
63 - LIQUID PRESSURE STOP VALVE	(V)	
75 - STRAINER PURGE VALVE	(S)	
76 - FREEZER PURGE VALVE	(P)	
90 - THAW GAS LINE STOP VALVE	(V)	
91 - CHECK VALVE	(C)	
HLS - HIGH LEVEL ALARM	(A)	
HLA - HIGH LEVEL SHUT-OFF	(S)	
T - THERMOMETER	(T)	
49 - FREEZER SUCTION STOP VALVE	(F)	
56 - FREEZER RELIEF VALVE	(R)	
58 - FREEZER PRESSURE SWITCH	(P)	
61 - FRZR. DIL/AMMONIA DRAIN	(D)	
62 - MAKE-UP WATER STOP VALVE	(S)	
63 - LIQUID PRESSURE STOP VALVE	(V)	
75 - STRAINER PURGE VALVE	(S)	
76 - FREEZER PURGE VALVE	(P)	
90 - THAW GAS LINE STOP VALVE	(V)	
91 - CHECK VALVE	(C)	
HLS - HIGH LEVEL ALARM	(A)	
HLA - HIGH LEVEL SHUT-OFF	(S)	
T - THERMOMETER	(T)	

FIGURE 3-15

Interconnecting Piping for Vogt P24AL and Central High Side

INSTALLING YOUR TUBE-ICE MACHINE

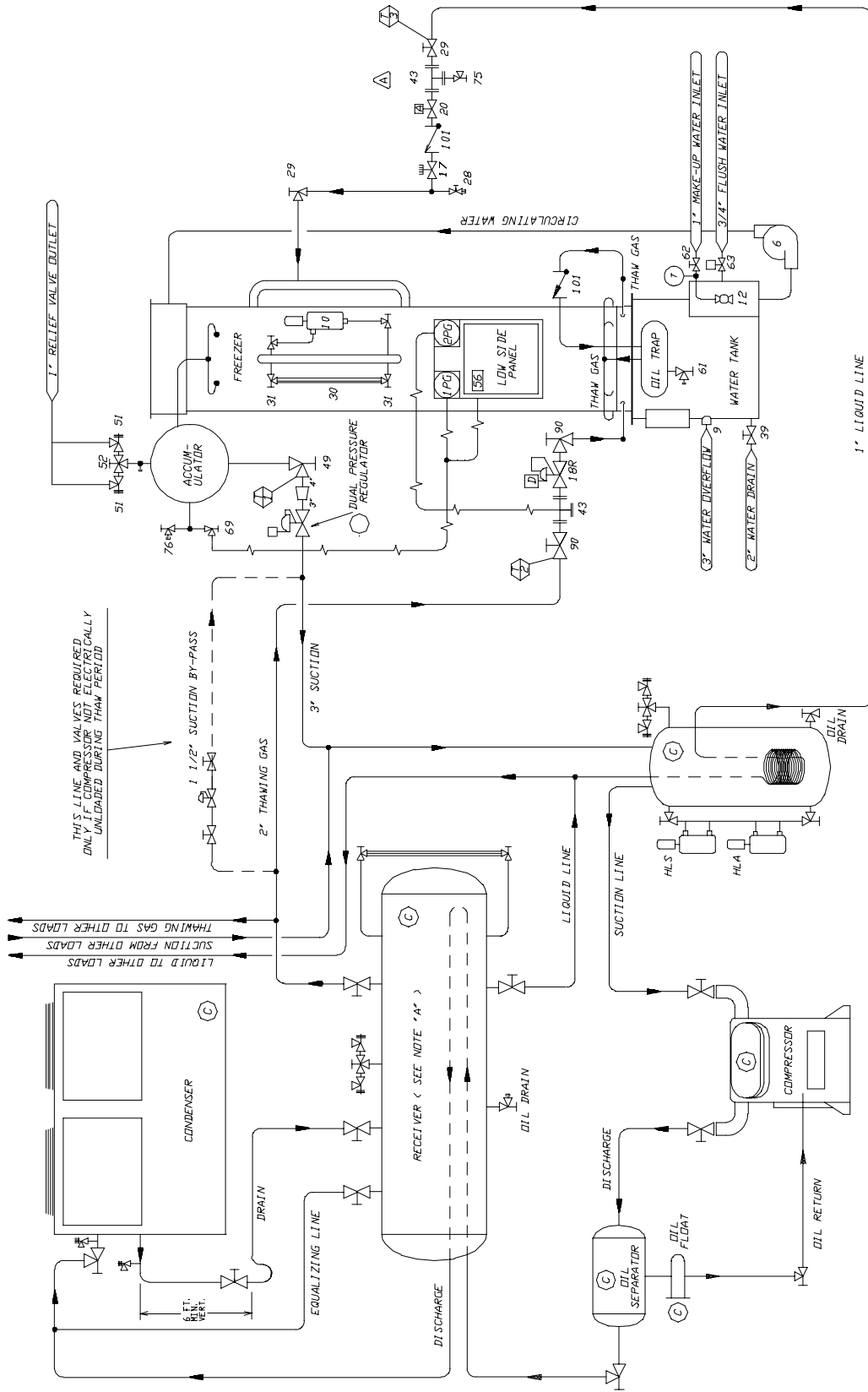

NOTE: THIS DRAWING IS FOR REFERENCE ONLY. IT IS NOT INTENDED TO BE USED AS A BASIS FOR INSTALLATION. DETAILED INSTALLATION DRAWINGS INDICATING PHYSICAL LOCATION AND RELATIVE POSITION OF COMPONENTS, SELECTION AND LOCATION OF SERVICE CONTROL, RELIEF VALVES, AND OTHERS, THE HENRY WOOD MACHINE COMPANY IS NOT RESPONSIBLE FOR THE SAFETY OR OPERATION OF EQUIPMENT PROVIDED BY OTHERS.

NOMENCLATURE		SYMBOLS		NOTE "A"	
1 PG - SUCTION PRESSURE GAUGE	49 - FREEZER SUCTION STOP VALVE	(C) - PARTS SUPPLIED BY CUSTOMER	(C) - RECEIVER REQUIREMENTS	50 - 50 CUBIC FEET MINIMUM WITH HEATING COIL	70 - 70 CUBIC FEET MINIMUM WITH HOT HEATING COIL
2 PG - DISCHARGE PRESSURE GAUGE	51 - FREEZER RELIEF VALVE	(D) - TERMINATION POINT	76 - HEATING COIL RECOMMENDED TO ASSURE THAT LIQUID AMMONIA IS AT SATURATED TEMPERATURE AT START OF EACH THAW PERIOD.	825 - 825 LBS. OF LIQUID AMMONIA REQUIRED IN RECEIVER FOR THAWING.	APPROX. TOTAL AMMONIA CHARGE IS 1600 LBS. USE 30°F SUCTION AND 100°F DISCHARGE WHEN SIZING CONDENSER.
6 - WATER TANK OVERFLOW CONNECTION	56 - 9-WAY VALVE	(E) - SOCKET WELD	1 - 1" MPT		
10 - REFRIGERANT FLOT SWITCH	61 - FREEZER PRESSURE SWITCH	(F) - SOCKET WELD			
17 - EXPANSION VALVE FLOT VALVE	65 - FLUSH WATER SOLENOID VALVE	(G) - TERMINATION POINT			
18R - THAW GAS REGULATOR/SOLENOID VALVE "A"	69 - LOW PRESSURE STOP VALVE				
28 - AMMONIA CHARGING VALVE	76 - FREEZER PURGE VALVE				
30 - LIQUID FEED SOLENOID VALVE "A"	78 - CHECK VALVE				
31 - LIQUID LEVEL GAUGE (GLASS)	101 - CHECK VALVE				
39 - WATER TANK DRAIN VALVE					
43 - STRAINER					

FIGURE 3-16
Interconnecting Piping for Vogt P34AL and Central High Side

INSTALLING YOUR TUBE-ICE MACHINE

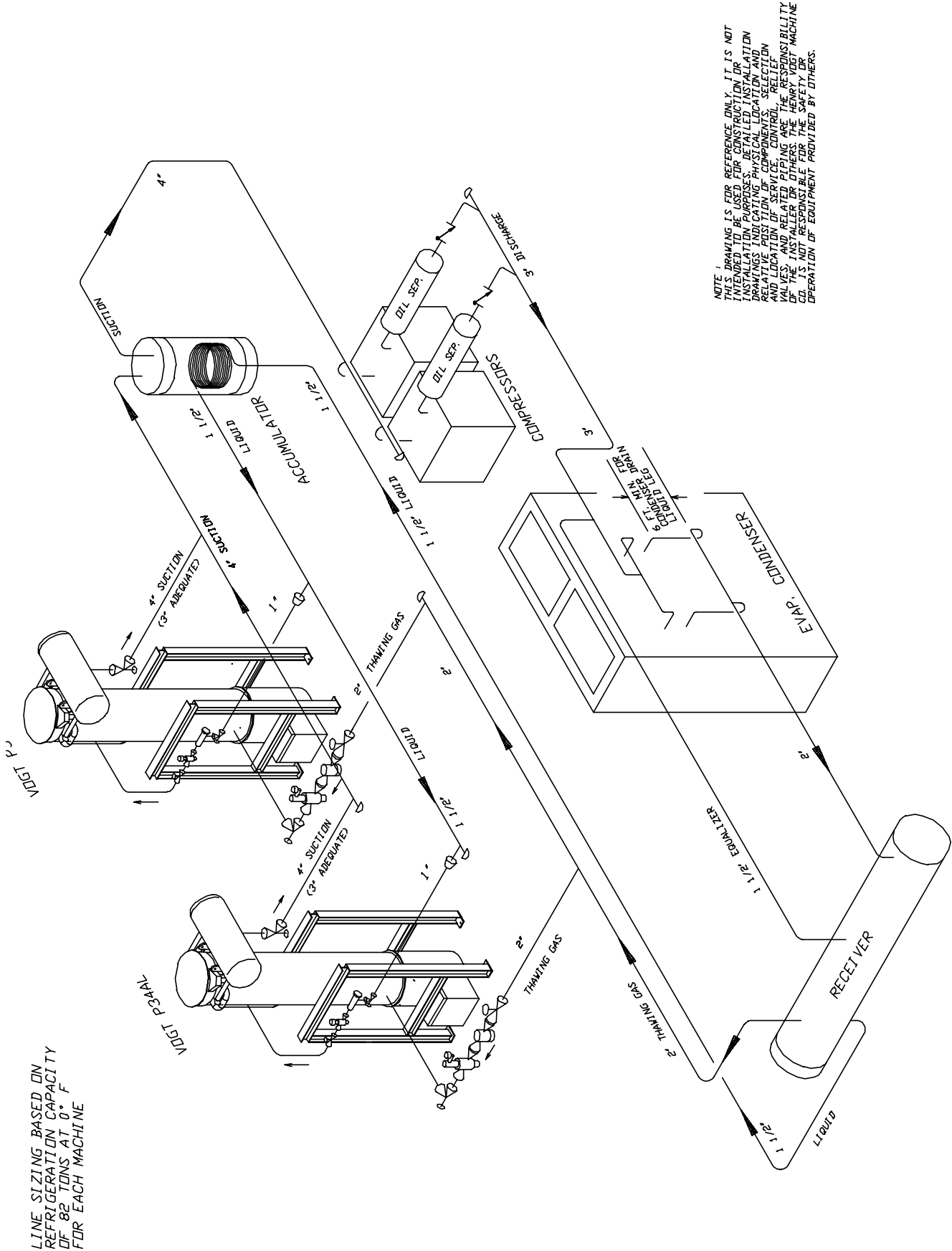

NOTE: THIS DRAWING IS FOR REFERENCE ONLY. IT IS NOT TO BE USED FOR INSTALLATION PURPOSES. CONSULT THE INSTALLATION MANUAL FOR DETAILED INFORMATION ON THE LOCATION AND POSITIONING OF COMPONENTS. SELECTION AND LOCATION OF SERVICE, CONTROL, RELIEF VALVES, AND OTHER ITEMS ARE THE RESPONSIBILITY OF THE USER. THE MANUFACTURER ASSUMES NO LIABILITY FOR THE SAFETY OR OPERATION OF EQUIPMENT PROVIDED BY OTHERS.

LINE SIZING BASED ON REFRIGERATION CAPACITY OF 82 TONS AT 0° F FOR EACH MACHINE

FIGURE 3-17
Interconnecting Piping for 2-Vogt P34AL and Central High Side

INSTALLING YOUR TUBE-ICE MACHINE

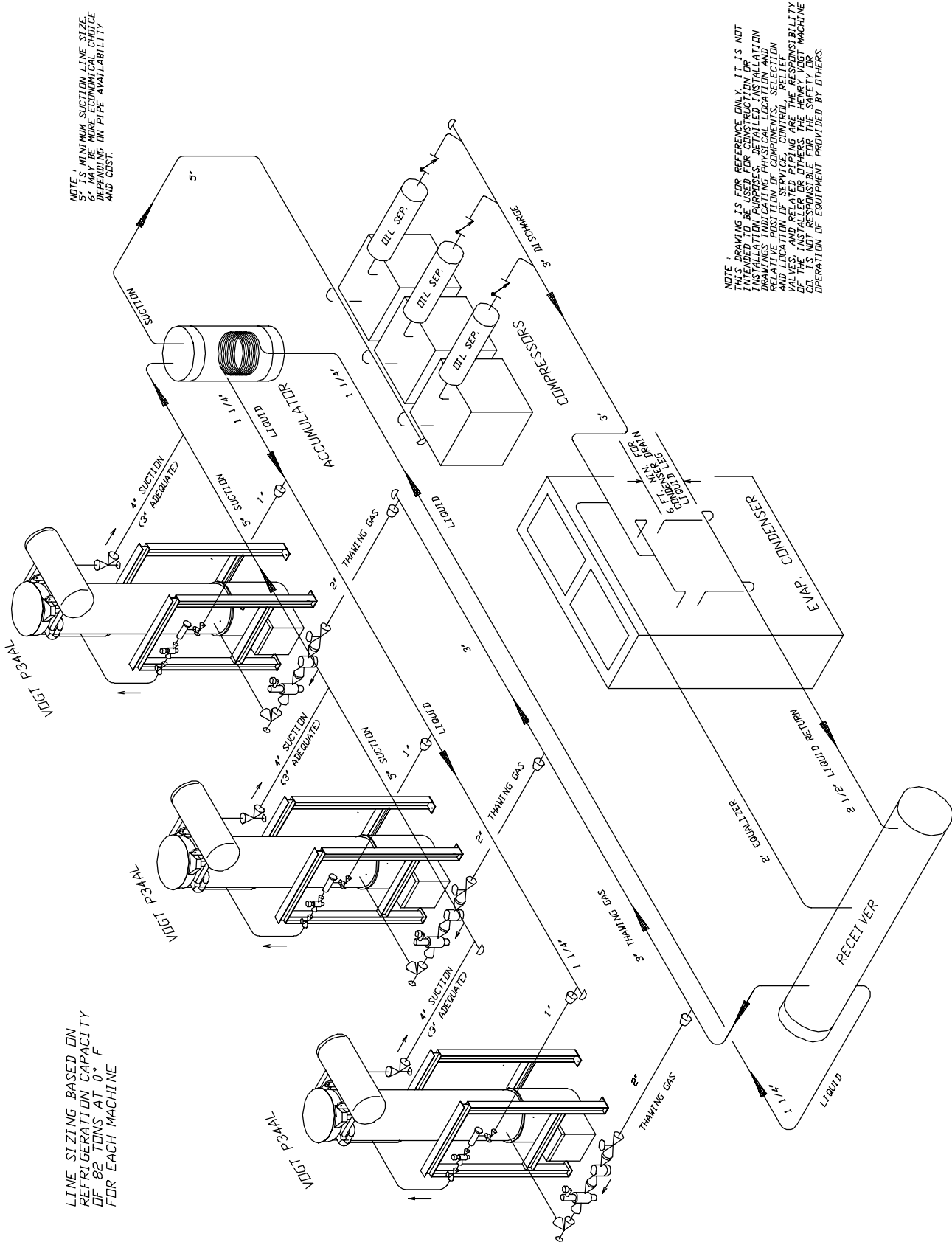

NOTE: 1/2" MINIMUM SUCTION LINE SIZE. 5" IS MORE ECONOMICAL CHOICE DEPENDING ON PIPE AVAILABILITY AND COST.

NOTE: DRAWING IS FOR REFERENCE ONLY. IT IS NOT TO BE USED FOR DIMENSIONED INSTALLATION PURPOSES. DETAILED INSTALLATION DRAWINGS INDICATING PHYSICAL LOCATION AND ALL DIMENSIONS OF COMPRESSOR, SELECTION VALVES AND RELATED FITTINGS ARE THE RESPONSIBILITY OF THE INSTALLER OR OTHERS. THE HENRY VOGT MACHINE CO. IS NOT RESPONSIBLE FOR THE SAFETY OR OPERATION OF EQUIPMENT PROVIDED BY OTHERS.

LINE SIZING BASED ON REFRIGERATION CAPACITY OF 82 TONS AT 0° F FOR EACH MACHINE

FIGURE 3-18
Interconnecting Piping for 3-Vogt P34AL and Central High Side

INSTALLING YOUR TUBE-ICE MACHINE

! IMPORTANT !

Be sure to follow the wiring schematic when incorporating overloads of conveyor (5 MOL). Also remove jumpers as instructed.

This is necessary to provide proper protection for the Tube-Ice® machine and its component parts.

! IMPORTANT !

Installation Review: A Checklist. Make a visual check to be sure these steps have been taken BEFORE continuing.

CHECK: _____ PRIOR TO OPENING VALVES, check all joints for leaks which may have developed during shipment. (NOTE: the machine was shipped with a positive pressure of 20-25 PSIG, which should be indicated on the suction and discharge gages.)

CHECK: _____ The system is properly evacuated to 500 microns.

CHECK: _____ All refrigerant piping, water supply and drain connections for conformity to requirements stipulated in this manual and properly connected to inlets and outlets.

CHECK: _____ Electrical supply for proper size of fuses and for compliance to local and national codes. See the machine nameplate for minimum circuit ampacity and maximum fuse size.

CHECK: _____ All field installed equipment (augers, conveyors, cooling towers, bin level controls, etc.) for proper installation.

CHECK: _____ The applicable portion of the warranty registration/start-up report for proper completion.

CHECK: _____ Cutter gear reducer oil level oil should run out of side pipe plug when removed.

CHECK: _____ The water distributors at top of freezer to make sure they are all in position (one seated firmly in each tube with a vent tube in each distributor).

! CAUTION !

The compressor crankcase heater should be energized for a minimum of four hours and the oil temperature should be 100-110°F before attempting to start the compressor.

! CAUTION !

4. How Your Tube-Ice Machine Works

Operating Features. Your Vogt low side Tube-Ice[®] machine is an efficient ice producing plant. If installed and maintained properly, it will give many years of operation with a minimum amount of repairs. Refer to piping schematics, FIGURE 4-1 and 4-2 to identify component parts while following the information and instructions in this manual.

The machine is manually started and stopped by the START and STOP push buttons. The machine will automatically stop by safeties such as, cutter and pump overloads, as well as other auxiliary motor overloads. It will also stop automatically by high head pressure, low suction pressure (if field wired to the high side). The circulating water pump can be operated independently for chemically cleaning the freezer tubes and water tank by use of the HAND/AUTO selector switch. The machine can be manually forced into a harvest cycle with the manual harvest push button.

Principle of Operation. The freezer (2) is a shell and tube-type vessel. During the freezing period (cycle), water is constantly recirculated through the vertical tubes of the freezer by a centrifugal pump (6). Make-up water is maintained by a float valve (12) in the water tank (7). The refrigerant float switch (10) opens and closes the liquid feed “A” solenoid valve (20) and maintains the desired refrigerant level in the freezer (2) (evaporator).

Refrigerant gas from the top of the freezer (2) passes through the suction accumulator (88) to the suction header and back to the compressor. The cool gas from the evaporator is compressed to a high temperature, high pressure gas which discharges through the oil separator (then through the heat coil of the receiver, when installed) and to the condenser. In the condenser, heat is removed and the gas is condensed to a high temperature, high pressure liquid. The high pressure liquid passes through the liquid line through a strainer (43), liquid “A” solenoid valve (20) check valve (101), and hand expansion valve (17). At the hand expansion valve (17), the refrigerant expands from a saturated high pressure liquid state to a low pressure, low temperature liquid. This cold liquid enters the freezer (2) where it absorbs heat from the circulating water in the freezer tubes. Cool gas is again pulled out of the freezer through the suction outlet, thereby completing the circuit.

The freezing period is completed by action of the freeze timer (1TR) in the control panel. The water pump (6) stops and the “A” solenoid valve (20) closes. After a delay of 20-30 seconds, the cutter motor starts, the thawing gas “D” solenoid valve (18R) opens, and the harvest (thawing) timer (2TR) is activated. Warm gas from the receiver is discharged through the thawing chamber (16), check valve (101), and into the freezer. There it warms the refrigerant and the outer surface of the freezer tubes, allowing the ice to release on the inside of the tubes and drop down onto the rotating cutter for sizing. After sizing, the ice drops on the tines cutter disc and is discharged through the ice discharge opening.

See “Freeze Period” and “Harvest Period” for more detailed description of machine.

Freeze Period. The Tube-Ice[®] is frozen inside the stainless steel tubes of the freezer (2) by the direct application of refrigerant to the outside shell side of the tubes. Ice is produced from constantly recirculating water down each tube. As the ice thickness increases, the freezer suction pressure decreases. At a set time the freeze timer (1TR) energizes the relay (1CR), which stops the water pump, closes the “A” liquid feed solenoid valve (20), de-energizes the suction regulator (when installed), turns out the two pilot lights, ammonia feed and freezing.

HOW YOUR TUBE-ICE MACHINE WORKS

Harvest Period. About 20-30 seconds after the 1CR relay is energized, the thaw gas valve (18) opens, the “H” water flush solenoid valve (63) opens, the compressor unloads (when required), the cutter motor starts, the thaw timer (2TR) is energized, the red thawing gas light illuminates, and auxiliary equipment such as conveyors etc. start. When the refrigerant in the freezer is warmed sufficiently, approximately 40°F / 5°C to allow the ice in the tubes to release and be sized. The ice is then discharged into the customers ice handling equipment. See “Ice Handling” for more information on this subject. **The thaw timer (2TR) is adjustable and should be set for the time required for all the ice to clear the freezer plus 30 seconds more.**

! CAUTION !

Make sure all the ice clears the freezer with at least 30 seconds to spare before the next freezer period begins. This is to prevent refreezing and to allow the ice moving augers etc. to clear.

! CAUTION !

1	Control Panel	36	Oil Trap
1PG	Suction Pressure Gauge	39	Water Tank Drain Valve
2PG	Discharge Pressure Gauge	43	Strainer
2	Freezer	44	Receiver Drain Valve
5M	Cutter Motor	46	Filter Drier
5R	Gear Reducer	49	Freezer Suction Stop Valve or Regulator
6	Water Pump	50	Receiver Safety Valve
7	Water Tank (includes cutter assembly)	51	Freezer Safety Valve
8	Water Distributing Chamber	52	3-Way Valve
9	Water Tank Overflow (3" FPT)	56	Freezer/Pressure Switch (2PS)
10	Refrigerant Float Switch	61	Freezer Oil/Ammonia Drain Valve
12	Make-Up Water Float Valve	62	Make-up Water Inlet Valve
16	Thawing Chamber	63	Water Flush Solenoid Valve
17	Hand Expansion Valve	69	Low Suction Pressure Stop Valve
18	Thawing Gas Regulator/Solenoid Valve "D"	75	Strainer Purge Valve
20	Liquid Feed Solenoid Valve "A1"	76	Freezer Purge Valve
28	Refrigerant Charging Valve	82	Thaw Gas Pressure Gage Stop Valve
29	Liquid Line Stop Valve	88	Accumulator
29A	Float Switch Stop Valve	90	Thawing Gas Stop Valve
30	Sight Glass	101	Check Valve
31	Gage Glass Stop Valve		

Piping Nomenclature

HOW YOUR TUBE-ICE MACHINE WORKS

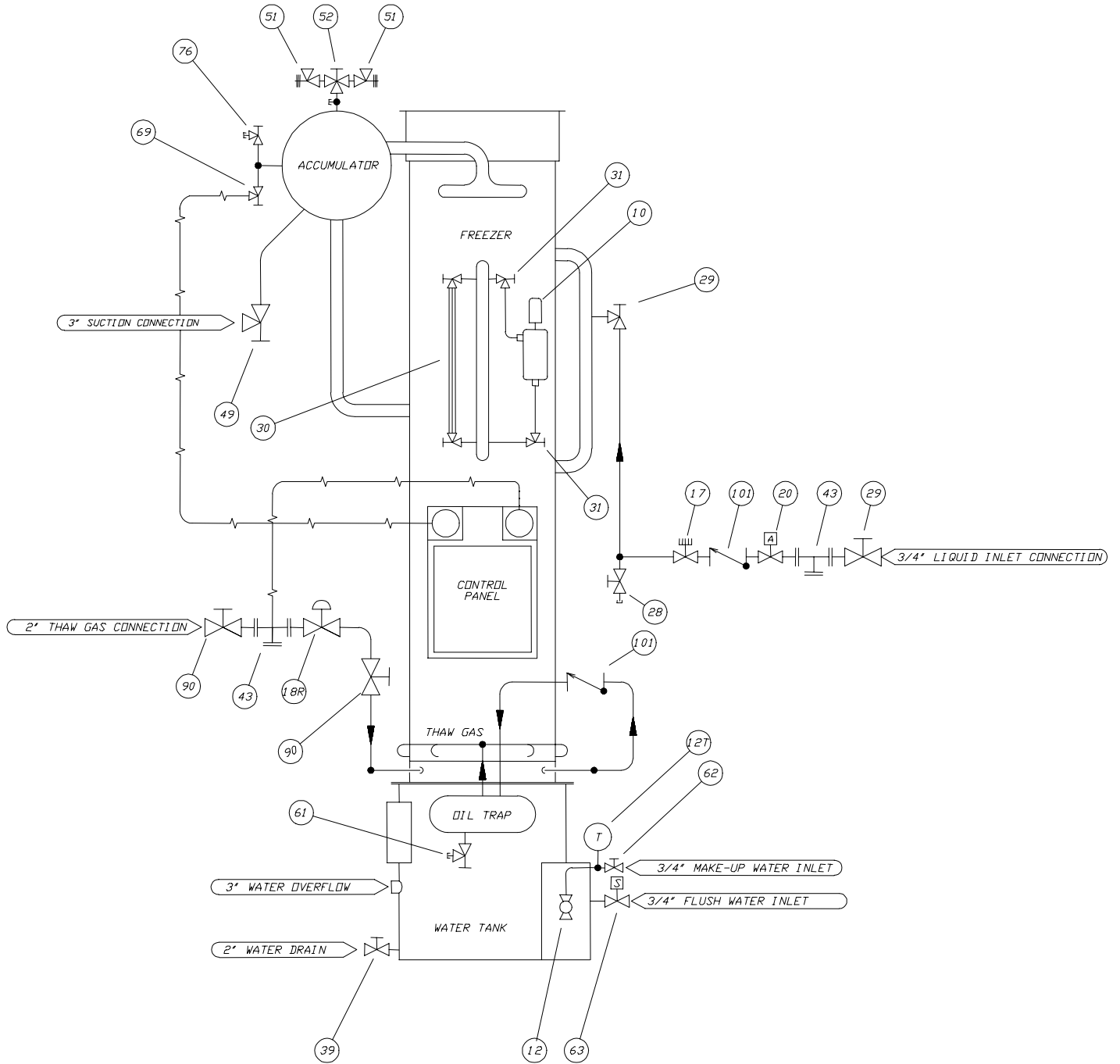

FIGURE 4-1
Piping Schematic for P24AL

HOW YOUR TUBE-ICE MACHINE WORKS

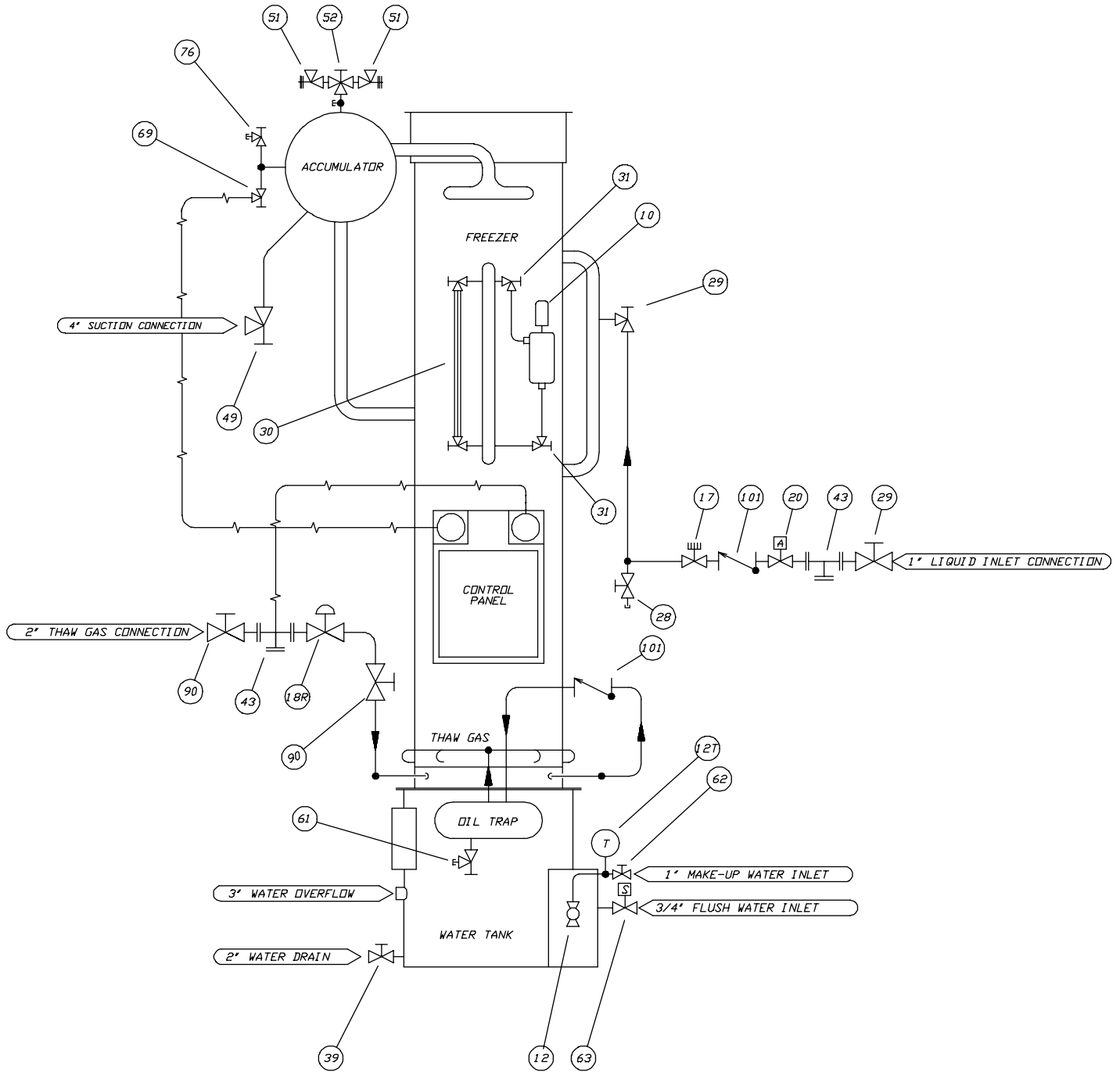

FIGURE 4-2
Piping Schematic for P34AL

5. Start-Up & Operation

Refrigeration System Review. The refrigeration system uses anhydrous ammonia (R-717) refrigerant. Following the piping schematic (Figure 3-12 to 3-16 and 4-1 or 4-2), you will see that during the machine's freeze cycle, the compressor discharge gas goes through the oil separator to remove any oil present in the discharge gas and return the oil to the compressor crankcase. It is then discharged into the condenser and condensed into a liquid by the removal of heat by water passing through the condenser tubes. A reservoir of liquid R-717 (approximate 325 lbs for P24AL and 625 lbs. for P34AL) is accumulated in the receiver and is required for thawing purposes (see Table 3-2). Liquid from the receiver flows through the strainer to the "A" solenoid valve (20) which opens and closes by action of the low side float switch (10). The liquid is then expanded through the hand expansion valve (17) and into the evaporator (2) (freezer). The cold wet R-717 refrigerant floods the evaporator and is in contact with the outside of the ice making tubes which water is being circulated through. The heat contained in the water passes through the wall of the tubes, lowering the temperature of the water causing it to freeze and form a long tube of ice that adheres to the inside of freezer tubes. Since the purest water freezes first, the circulating water continues to wash the dissolved solids down into the sump area of the water tank. The flushing valve helps to rid the water tank of increased dissolved solids by flushing them out the overflow during the harvest (thawing) period.

The wet suction gas leaves the freezer and passes through the suction accumulator (88), where liquid droplets are removed, allowing dry gas to enter the suction side of the compressor. The suction gas is then compressed and discharged once again, completing the cycle. As ice continues to form in the freezer tubes, the suction pressure steadily decreases, when the freeze timer (1TR) times out the contact closes, initiating the thaw (harvest) cycle.

Note: Freezing time will vary, depending on make-up water temperature and thickness of ice produced. The freeze timer (1TR) should be set to provide the correct time to produce ice at the required thickness under the current operating conditions.

During the harvest period, the "D" thawing gas valve (18) opens and the compressor unloads (when required), allowing the warm high pressure gas from the receiver to enter the freezer. As the tubes warm up to slightly above freezing (approximately 40°F / 5°C), the ice inside the tubes releases and falls down onto the rotating cutter for sizing and discharging. Harvesting requires about three minutes, but can vary depending on ice thickness, suction pressure, discharge pressure (thawing gas temperature) and distance from the receiver to the freezer.

! IMPORTANT !

It is a good idea and will be profitable for you to observe and become familiar with the proper operating characteristics of your Tube-Ice[®] machine. It will help you to recognize and correct minor irregularities as they occur in order to help prevent major problems.

“An ounce of prevention is worth a pound of cure.”

! IMPORTANT !

START-UP & OPERATION

Start-up Checklist. Be sure to complete and return the “Warranty Registration/Start-up Report” located in the front of the manual.

1. See that the water-inlet connections are attached properly. The water inlet shutoff valve (62) for the water tank should be open. The water level in the water tank should be at a height where the make-up float valve will be closed when the machine is idle and water is not running out of the overflow (9).
2. Fill the cooling tower sump and check the tower manufacturer’s installation and operation instructions to make sure it is ready to run.
3. Check condenser cooling water pump rotation.
4. Check rotation of augers or ice handling equipment to make sure they are rotating the proper direction.
5. Check all tagged valves and make sure they are in their correct operational position (opened, closed, or automatic).
6. See that the electrical disconnect is closed and the proper power is supplied to the machine.
7. See that the compressor oil temperature is 100-110°F and there is no liquid ammonia in the crankcase. The oil level should be 1/2-3/4 of the sight glass.
8. Check the elapsed time indicator (ET) and make sure wire #22 and #27 are attached.
9. Reconfirm “Rotation Check” for cutter and water pump (See Section 3).

Refrigerant Charge. Prior to charging the machine with anhydrous ammonia (R-717) make sure the system is leak tight and free of non-condensibles or other contaminants.

The machine will require a full charge of pure anhydrous ammonia. Make sure it is from a reputable supplier who can and will furnish quality ammonia of Refrigeration or Federal Technical grade.

Grade	Minimum Ammonia Content	Maximum Water Content	Maximum Oil Content	Maximum Non-condensable
Fertilizer	99.50%	5000 PPM	5 PPM	N/A
Refrigeration	99.98%	150 PPM	3 PPM	.2 ml/g
Federal Technical	99.98%	200 PPM	5 PPM	None
Metallurgical	99.99%	33 PPM	2 PPM	10 ml/g
Research	99.999%	5 PPM	1 PPM	7 PPM

TABLE 5-1
Ammonia Specification By Grade
(Reference IAR Ammonia Data Book Chapter 1, General Information)

NOTE: Do not use Fertilizer grade ammonia.

Total ammonia (R717) charge required is approximately;

Dedicated System - P24AL = 1000 lbs.

P34AL = 1600 lbs.

Evaporator only - P24AL = 500 lbs.

P34AL = 950 lbs.

Special precautions to be observed when charging refrigeration systems. Only technically qualified persons, experienced and knowledgeable in the handling of anhydrous ammonia refrigerant and operation of refrigeration systems should perform the operations described in this manual. All local, federal, and EPA regulations must be strictly adhered to when handling ammonia (R717) refrigerants. See “Material Safety Data Sheet”, MSDS Code5B81-83, located in the Appendix A.

Charging From Tank Truck (dedicated high side only). The system may be charged by bulk from a tank truck and be pumped directly into the receiver through the drain valve.

Follow these instructions with caution:

1. Using a ammonia approved charging hose, connect one end to the drain/charging valve in the bottom of the high pressure receiver.
2. Connect the other end of the charging hose to the tank truck. It is best to have a gage in this line to indicate pressure.
3. Open the drain/charging valve and the fill valve from the tank truck.
4. While observing the sight glass on the high pressure receiver, fill the receiver to the proper volume.
5. Make sure the charging valve is closed and the cylinder valve is closed before attempting to disconnect the hose. Use caution when disconnecting the charging hose, it will contain liquid ammonia and should be disposed of in accordance with local, state and federal safety and environmental rules.

! CAUTION !
Do NOT attempt to bulk charge the machine through the freezer charging valve (28). The freezer will not hold the full charge without exposing the compressor to serious damage.
! CAUTION !

Charging From Cylinders (dedicated high side only). The machine may also be charged from refrigerant cylinders. To charge from cylinders, the compressor will have to operate to transfer the ammonia from the freezer to the receiver. Again, make sure all the necessary valves are opened for operation and the compressor crankcase heater has been energized for a minimum for four hours.

Follow these instructions with caution:

1. Using a approved for ammonia charging hose, connect one end to the charging valve (28) in the liquid line near the freezer.
2. Lay a full cylinder of anhydrous ammonia horizontally with the cylinder valve outlet pointing up to withdraw liquid and the bottom end raised about 2" higher than the top end.
3. Connect the other end of the charging hose to the cylinder valve. It is recommended that a gage be attached to this line to indicate cylinder pressure.
4. Close the liquid line stop valve (29) or at the receiver.
5. Open charging valve (28) and carefully purge air from the charging hose.
6. Open the cylinder valve slowly, checking for leaks in the line and allow the suction pressure to build up to approximately 40 psig and check again for leaks in the system.
7. Set the freeze timer (1TR) to maximum setting. If the machine contains a pressure switch (2PS) in place of the freeze timer, disconnect and locked out the power, open the control panel door and disconnect wire #24 from the freezer pressure switch (2PS), then turn the power back on.
8. Check compressor rotation by starting and stopping the compressor momentarily. If the compressor starter is wired to (3CR) then jog the compressor by using the green "Start" push button (2PB) and the red "Stop" push button (1PB). Correct compressor rotation is indicated by an arrow on the outer rim of the oil pump assembly (opposite the shaft end of the compressor).
9. Set the Hand/Auto switch (1SS) to the "Hand" position allowing the circulating water pump to circulate water through the freezer.

START-UP & OPERATION

10. As the pressure continues to rise in the freezer, start the compressor and pump the ammonia into the receiver. Make sure water is circulating through the condenser and freezer tubes.

If a refrigeration system is being charged from refrigerant cylinders, disconnect each cylinder when empty or when the system is fully charged. A gage should be installed in the charging line to indicate refrigerant cylinder pressure. The cylinder may be considered empty of liquid R-717 refrigerant when the gauge pressure is 25 pounds or less and there is no frost on the cylinder. Close the refrigerant charging valve and cylinder valve before disconnecting the hose from the cylinder. Loosen the union in the refrigerant charging line--carefully to avoid liquid ammonia release into the atmosphere.

! CAUTION !

Immediately close system charging valve at commencement of defrost or thawing cycle if refrigerant cylinder is connected. Never leave a refrigerant cylinder connected to system except during charging operation. Failure to observe either of these precautions can result in transferring refrigerant from the system to the refrigerant cylinder, over-filling it, and possibly causing the cylinder to rupture because of pressure from expansion of the liquid refrigerant.

! CAUTION !

Transferring refrigerant from a refrigeration system into a cylinder can be very dangerous and is not recommended.

As the machine is being charged, continually observe the following operating characteristics:

- a) Discharge pressure - 175 psi to 200 psi maximum
- b) Compressor oil pressure - Mycom W-Series, 18-27 psi, Vilter 450-Series, 35-50 psi.
- c) Liquid level in receiver
- d) Compressor oil level

While charging the machine, the low pressure switch will stop operation of the compressor at set point pressure. The switch will automatically reset at the differential pressure at which time you can restart the machine, (some low pressure switches may be manual reset). It is best to use warm water in the tank and open the tank drain valve somewhat to allow cold water to exit and warm water to enter continually. The idea is to prevent ice from freezing in the tubes as much as possible while charging. It may be necessary to initiate a short harvest cycle to dispel any ice made. To initiate a harvest cycle, close the charging valve and push the manual harvest push button (3PB) while the compressor is running. As soon as all the ice clears the cutter area, turn the Hand/Auto switch to "Hand" and then back to "Auto". This will stop the harvest and start another freeze to continue the charging procedure. When the liquid level in the receiver is near the pumpdown level and the freezer is down to 15 psi suction with little or no frost on the shell, you can stop the charging procedure and disconnect the cylinder. Make sure the charging valve is closed and the cylinder valve is closed before attempting to disconnect the cylinder. Loosen the union in the charging line gradually to relieve the ammonia pressure slowly.

When charging is complete, stop the machine, disconnect and lock-out the power. If the machine contains a pressure switch (2PS), open the control panel door and reconnect wire #24 to the freezer pressure switch. Open valve #29 and/or receiver liquid feed valve and you will hear liquid

refrigerant flowing through to the liquid solenoid valve #20. Turn main power disconnect to the on position and the machine is ready for start-up and ice production.

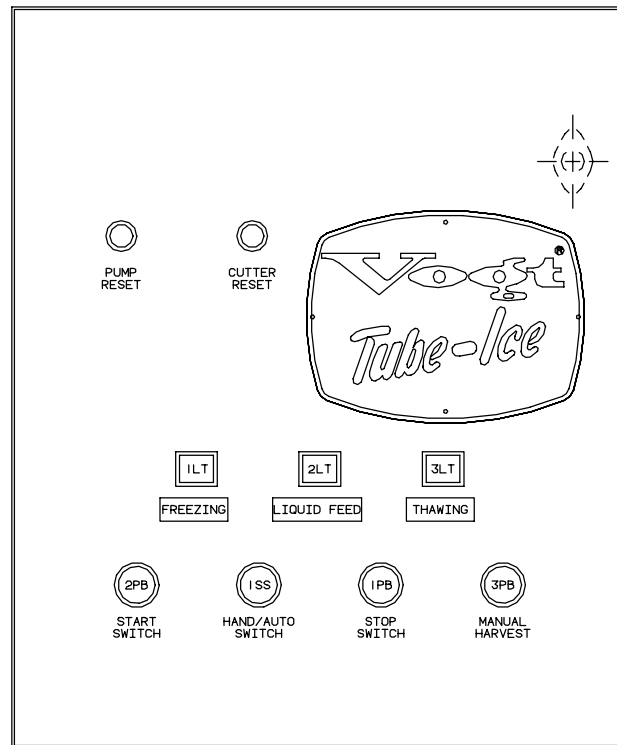

FIGURE 5-1.
Control Panel

Start-Up. Starting the machine in a freezing cycle can be accomplished as follows:

1. Make sure the crankcase oil temperature is approximately 100°F and there is no liquid ammonia in the compressor crankcase.
2. Turn the Hand/Auto switch (1SS) to the “Hand” position and allow the water tank to refill. **MAKE SURE THE DRAIN VALVE IS CLOSED.**
3. If the compressor motor starter is wired to the control relay (3CR) then push the green “Start” push button to start the compressor and immediately observe the oil pressure, the oil level, the discharge pressure, and listen for any unusual sounds. The compressor should start unloaded and will load automatically after several seconds of operation.
4. Turn the Hand/Auto switch to the “Auto” position.
5. When the discharge pressure increases to about 170 psi, push the “Manual Harvest” button to initiate the harvest cycle. See “Harvest Period”.
6. Set the thaw gas pressure regulator (18R) and the suction regulator (if used). See “Thaw Gas Regulator” and “Suction Regulator” for instructions.
7. When the suction pressure raises to 50-55 psig, any ice made should release and discharge. After all of the ice clears the cutter and auger, turn the Hand/Auto switch to “Hand” and back to “Auto”. This will interrupt the harvest cycle and start another freeze cycle. See “Freeze Cycle”.

As the machine continues its freezing cycle, the liquid ammonia will feed into the freezer until the level float switch (10) is satisfied. The float switch will open and close the liquid line solenoid valve

START-UP & OPERATION

(20) to maintain that level of ammonia in the freezer during the freeze cycle. When the freeze timer (1TR) times out the switch will close and initiate the harvest cycle. If a freezer pressure switch (2PS) has been installed, the suction pressure will decrease to the setting of the freezer pressure switch (2PS), the switch will close and initiate the harvest cycle. See “Harvest Period”.

Be sure to observe several complete cycles of ice production to confirm the satisfactory operation of the machine.

! IMPORTANT !
Complete the remaining part of the “Warranty/Registration Start-Up Report” and return it to the Henry Vogt Machine Co.
! IMPORTANT !

Check the refrigerant level at the receiver liquid gage glass to make sure it is near the operating level mark.

Adding Refrigerant. Add refrigerant while the machine is running by the following procedure:

1. With a cylinder of anhydrous ammonia laying on its side, cylinder valve outlet pointing up and bottom end raised two inches higher than the valve end, connect an “approved for ammonia” charging hose between the freezer charging valve (28) and the cylinder valve.
2. Purge all air from the charging hose and open the cylinder valve gradually to check for possible leaks around the packing nut or hose fittings. Then open the cylinder valve fully.
3. While the “ammonia feed light is not illuminated, open the charging valve (28) and ammonia will flow from the cylinder to the freezer.
4. Close the cylinder valve immediately when the ammonia feed light comes on and reopen it when the light goes out. Repeat until properly charged.

! CAUTION !
Do not leave a refrigerant cylinder attached to the machine unattended. Disconnect it immediately when the machine is charged or the cylinder is empty.
! CAUTION !

Operating Tips.

- Make sure the machine is left running in the “Auto” position. This will assure a complete shutdown if a safety or overload is tripped.
- To initiate a harvest cycle, simply push the Manual Harvest push button (3PB).
- To interrupt the harvest cycle (harvest timer #2TR) and revert to a freeze cycle, turn the Hand/Auto switch to “Hand” and back to “Auto”.
- The circulating water overflow tubing will show that water is being slightly lifted up the tubing near the end of the freezing cycle. If this action ceases and water begins overflowing from the top water box, it is an indication that the tubes are freezing solid and the machine should begin a harvest cycle. It is best not to freeze the ice solid with no hole.
- To cease ice production manually, allow the machine to complete the harvest period and start the freeze period. When the “liquid feed” light comes on at the beginning of the freeze period, push the “Stop” button to cease ice production.

Thaw Gas Regulating and Suction Regulating Valve Adjustment. The following is the procedure for regulating valve adjustment. On dedicated compressor systems the suction regulating valve is not required. However the compressor must unload by 50% or greater during the harvest or a hot gas bypass must be installed.

1. Install gauge and gauge valve in gauge port of regulator.
2. Turn high pressure stem (down stream pressure) on suction regulator into the milled flats, do not turn milled flats into packing nut.
3. Start the machine and initiate a harvest.
4. Adjust the thaw gas regulator to build pressure to 60 - 65 psig. (1 turn is approximately 13 psig)
5. Adjust (downstream) high pressure stem on suction regulator to begin regulating at 59-64 psig. (slightly below the thaw gas regulator)
6. After the machine has completed the harvest cycle and returned to the freeze cycle, adjust the low pressure (upstream pressure) on the suction regulator to maintain the required freezer pressure. For clear ice a minimum of 20 psig freezer pressure is required.

START-UP & OPERATION

6. Electrical Controls

Your packaged Tube-Ice[®] machine is equipped with a compressor motor starter contact (3CR) and a transformer (if required) for the control circuit power. The control panel and transformer are mounted on the machine front side (see Figures 1-1 or 1-8).

The control panel wiring schematic, FIGURE 6-3, illustrates these components as well as provisions for auxiliary equipment which may be incorporated by the customer such as:

- (FU1) Main power disconnect
- (5M) Conveyor motor starter and overload (5MOL)
- (C-SOL) Suction regulating valve

When adding motor starters for auxiliary equipment, be sure to incorporate the overload protection as indicated between terminals #12-#13 and remove the jumper wire. This will assure that the machine will shutdown when any auxiliary equipment fails.

Bin Level Control. Included in the wiring schematic is provision for a bin level control (BLC). The NC contact of your control should be wired between terminals #8-#9 and the jumper wire removed as indicated. Installation in this manner will allow the machine to finish the harvest period before shutdown. However, the machine will still need to be manually started to resume production.

Safety Switches. The machine is not equipped with the following safeties and control switches, however they can be wired into the control circuit. Refer to the wiring schematic FIGURE 6-3 for their circuitry.

- High/Low dual pressure switch (1PS) to stop the machine if the compressor suction pressure goes too low (15-20 psi) or the compressor discharge pressure goes too high (225-250 psi). See “High/Low Pressure Switch”.

ELECTRICAL CONTROLS

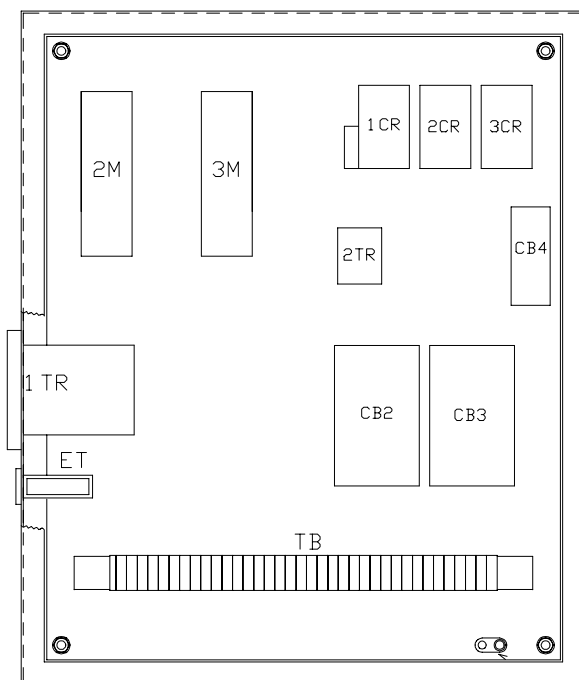
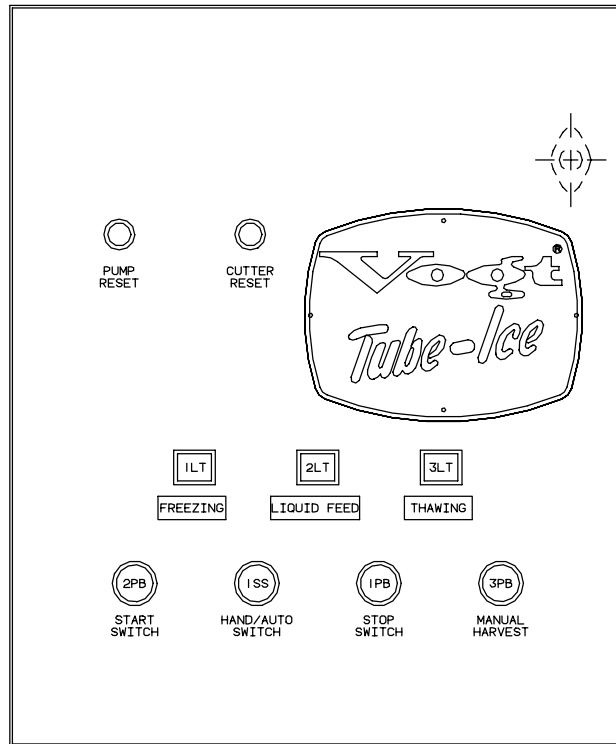

FIGURE 6-1
Control Panel (Door Opened)

(3CR)	Compressor Motor Starter contact and holding relay	Holding relay for safety and bin level control. Auxiliary contact provides control power to the compressor motor starter. Continuously energized during freezing and thawing.
(2M)	Pump Motor Starter	Provides power to the circulating water pump during the freezer period or when the Hand/Auto switch is in the "Hand" position to circulate water or ice machine cleaner, etc.
(3M)	Cutter Motor Starter	Provides power to the cutter during the harvest period.
(1CR)	Control Relay With Pneumatic Timer	For making and breaking various circuits during freezing and thawing period with pneumatic timer to delay the actual thawing process. Energized during thawing.
(2CR)	Control Relay	For making and breaking circuits during freezing and thawing. Energized during freezing, thawing, and hand. Momentarily de-energized at the end of the harvest.
(2TR)	Thawing Timer	Controls the time of the harvest (thawing) period. Energized during the harvest period.
(1TR)	Freeze Timer	Controls the length of time the machine is in the freeze cycle. When timed out initiates the harvest cycle.
(2PS) optional for dedicated high side	Freezer Pressure Switch	Controls the desired ice thickness (hole size) by sensing the freezer suction pressure and initiating the harvest period.
(ET)	Elapsed Time Indicator	Indicates total hours of machine operation. Is powered when the compressor is running.
(CB4)	Circuit Breaker	Overload and short circuit protection for crankcase heater and the control circuit.
(CB2)	Circuit Breaker	Secondary protection for the circulating water pump motor.
(CB3)	Circuit Breaker	Secondary short circuit protection for the cutter motor.
(TB)	Terminal Block	Numbered for multiple wire connections and ease of troubleshooting.

TABLE 6-1
Description of Control Panel Parts (Inside)



**FIGURE 6-2
Control Panel (Hinged Door)**

(1LT)	Amber Pilot Light - Freezing	Illuminated during the freeze period or whenever the circulating water pump is running.
(2LT)	Clear Pilot Light - Liquid Feed	Illuminated when the circulating water pump is running and the float switch (10) is closed. Indicates that the liquid line solenoid valve (20) is opened.
(3LT)	Red Pilot Light - Thawing	Illuminated when the machine is in a harvest period.
(2PB)	Green Push Button - Start	For starting the compressor motor and ice production. (NO)
(1PB)	Red Push Button - Stop	For stopping the compressor motor and ice production. (NC)
(3PB)	White Push Button - Manual Harvest	For manually initiating a harvest cycle. (NO)
(1SS)	Selector Switch - Hand/Auto	“Hand” position for running the circulating water pump independently at start-up or for cleaning the freezer tubes and water tank. “Auto” position for provision of automatic system shutdown if there is a control circuit power interruption.

**TABLE 6-2
Description of Control Panel Parts (Outer Door)**

ELECTRICAL CONTROLS

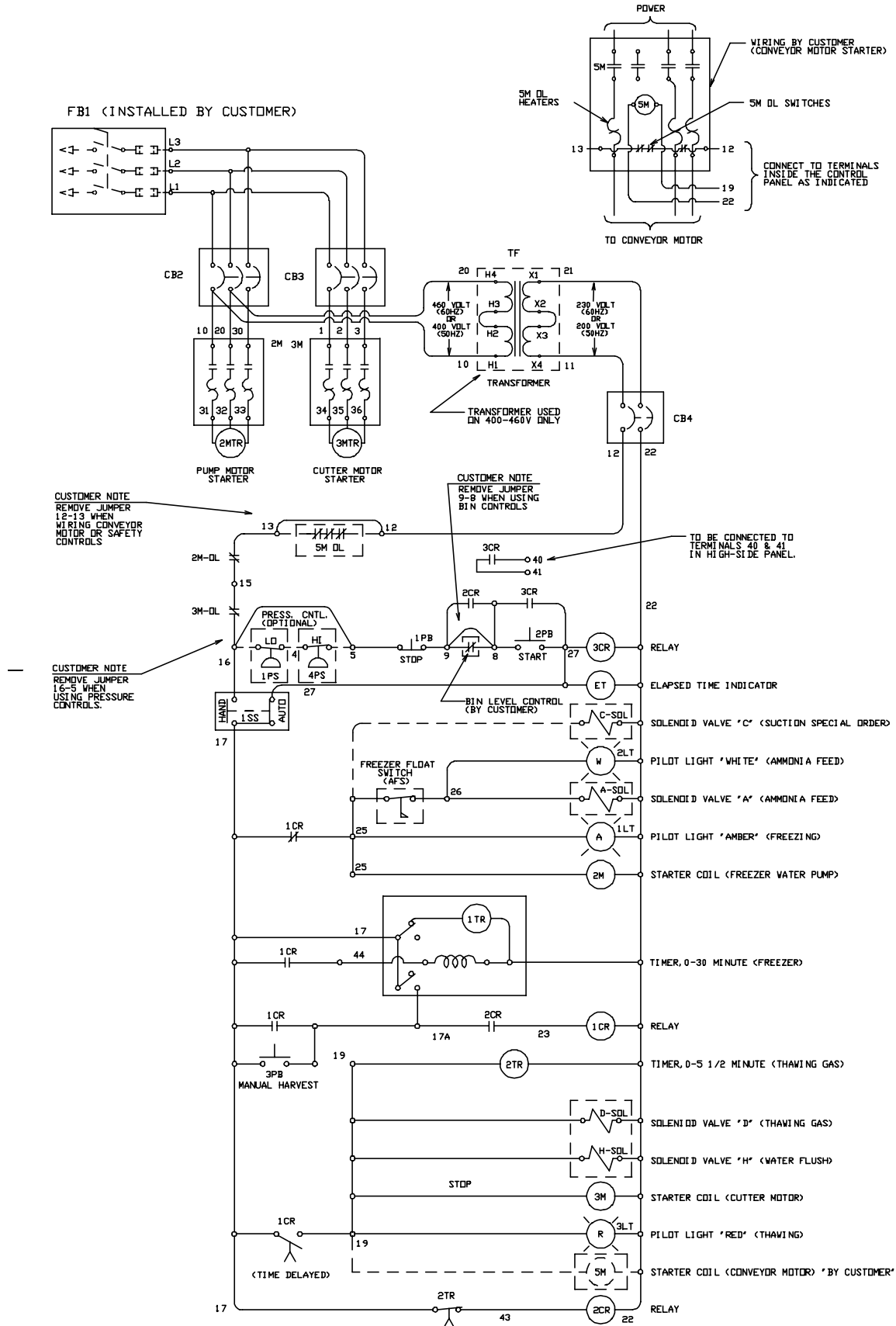

FIGURE 6-3
Electrical Schematic for P24AL and P34AL all Voltages, 50-60 Hz.

7. Maintenance

Preventative Maintenance. A careful inspection of the Tube-Ice[®] machine for leaks and correct operational functions at the time of installation and start-up will begin its long satisfactory life of service. In order to insure this degree of dependability, a systematic maintenance program is necessary. Therefore, the following schedule is suggested as a minimum.

A. Daily

- 1) Check operating pressures (suction, discharge, oil).
- 2) Check ice quality.
- 3) Check "ice out" time (maintain 30 seconds of continued harvest after last ice is out).
- 4) Check compressor oil level.
- 5) Check refrigerant operation level.
- 6) Check frost pattern on freezer shell and oil trap.
- 7) Check make-up water float valve adjustment.

B. Weekly (in addition to daily checks)

- 1) Check for leaks after 400 hours or four weeks of operation

C. Monthly (in addition to weekly checks)

- 1) Check calibration and operation of all controls (high and low pressure switches, oil pressure switch, etc.)
- 2) Check cooling tower spray nozzles and pump suction screen for scaling and algae (consult water treatment suppliers for corrective measures).
- 3) Check water distributors in freezer for scale accumulation.
- 4) Check water tank for solids to be removed.
- 5) Check all motor drive units (compressor, cutter and pump motors, cooling tower fan, and pump, etc) for abnormal noise and/or vibrations.
- 6) Check oil level in gear reducer.
- 7) Check one complete freeze/thaw cycle, record data and compare with production check of Registration/Start-up Report.

D. Yearly (in addition to weekly and monthly)

- 1) Check entire system for leaks.
- 2) Drain water from condenser and cooling tower and check condenser tubes. Check closely for damage by corrosion or scale.
- 3) Remove all rust from all equipment, clean, and paint.
- 4) Check all motors for shaft wear and end play.
- 5) Check operation and general condition of all electrical controls, relays, motor starters, and solenoid valves.
- 6) Check freezing time, ice release time, and ice out time.
- 7) Change oil in gear reducer box once a year.
- 8) Lubricate compressor motor bearings.

PREVENTATIVE MAINTENANCE FORM

This form can be removed and duplicated for record keeping.

Date: _____ Model #: _____ Serial #: _____

The following service performed and checked:

- Hour meter reading _____ , Ambient temperature (inside) _____ °F
- Make-Up water float valve adjusted properly
- Water distributors clean and in place
- All drains freely draining
- Cleaned and flushed water tank
- Compressor oil changed
- Cleaned and inspected inside compressor crankcase
- Changed compressor oil filter
- Checked/adjusted compressor belt tension or alignment
- Lubricate compressor motor bearings
- Check/change cutter gear reducer oil
- Check/adjust cutter drive gear meshing
- Leak check entire system
- Check liquid refrigerant level in receiver
- Drained oil from oil trap
- Compressor crankcase heater working
- Compressor net oil pressure (gage reading less suction)

Motor amps: Compressor _____ Cutter _____ Pump _____
 Suction psig (end of freeze) _____ Discharge psig (end of freeze) _____
 Suction psig (end of thaw) _____ Discharge psig (end of thaw) _____
 Compressor water out _____ °F Tower fan cycles ___ On ___ Off

Production Check

Test Cycle	Make-up Water Temp	Freezing Time Min/Sec	Harvest Time Min/Sec	First Ice Out Min/Sec	All Ice Out Min/Sec	Avg. Hole Size	Ice lb. Per Harvest (est)	Ice lb. Per Day (est)
#1								
#2								
#3								
#4								

Comments: _____

Name: _____

Ice Making Section. The ice making section of the Tube-Ice[®] machine should be cleaned at least twice a year (more often if water conditions cause mineral build up). Use an approved food-grade ice machine cleaner. The water pump is used to circulate the cleaner through the system. For complete instructions, follow the “Cleaning Procedure” below.

Cleaning Procedure.

1. Stop the machine at the end of harvest.
2. Shut off make-up water supply.
3. Drain the water tank, flushing out any loose sediment.
4. Close the drain valve and fill the tank with warm water. Warm water promotes faster cleaning.
5. Cover the ice discharge opening to prevent water from splashing out and contaminating any stored ice.
6. Add sufficient ice machine cleaner to the water tank.
 P24 tank = 2.5 gallons water per inch of water height in tank, 13” = 32.5 gallons
 P34 tank = 4.7 gallons water per inch of water height in tank, 13” = 60.6 gallons
 Mix cleaning solution according to manufacturer’s recommendations.
7. Remove top water box cover, inspect distributors, remove any hard particles from orifices, and make sure all distributors are in place. Replace cover.
8. Turn Hand/Auto switch to “Hand” position and circulate the cleaning solution until deposits are dissolved or the solution is neutralized. After draining, the pump may have to be stopped and restarted to dispel air.
9. Turn switch to “Auto” position to stop the pump. Drain and flush the water tank. Repeat cleaning as necessary.
10. After cleaning, fill the tank with fresh water, start the pump again, and circulate for 15 minutes.
11. Stop the pump, drain and flush the tank and again refill with fresh water.
12. Remove the cover from the ice discharge opening, and clean any area that may have been splashed with solution during cleaning.
13. Make sure the make-up water float valve is adjusted properly and the drain valve is closed.
14. Start and stop the pump again to make sure it is circulating water and it is not air bound.

You are now ready to produce ice.

Water Distributors. The water distributors are located under the top freezer cover. These distributors are similar in design to those used in mid-size and small machines (i.e. P18F, P118, etc.) except they have a small vent tube. It is important that this plastic vent tube remain in place in each distributor. The distributors may require occasional or periodic cleaning to remove solids, foreign particles, or mineral deposit accumulated from the circulating make-up (ice making) water. The frequency of cleaning operation will depend on the characteristics of the water supply. The distributors need inspection when the inside diameter of a large portion of the ice becomes irregular (due to channeling of water), if some of the ice is opaque or if there is a noticeable decrease in ice capacity and quality.

Tube Size	1 1/2”	1 1/4”	1”
-----------	--------	--------	----

Model	Number of Distributors		
	P24A	144	198
P34A	306	420	564

TABLE 7-1
Water Distributors

You may look through the plastic freezer cover to inspect the water distributors if the view is clear. For a closer inspection you should stop the unit, remove the nuts and retaining ring sections and lift off the top cover. Make sure the two orifices in the side of each distributor are open, the vent tubes are in place, and a distributor and vent tube assembly is installed firmly in each tube.

To remove the water distributors for cleaning:

1. Grip the top of the distributor body (not at the vent tube) with adjustable pliers.
2. Hold and twist the distributor while pulling upward.
3. Lift the distributor out of the hole.

To install the distributors:

1. Insert one in each tube hole and seat firmly by using a short piece of pipe or conduit.
2. Slide the pipe or conduit down over the vent tube and gently tap the distributor in place.
3. Do not allow the distributor to be recessed below the top of the tube sheet.

To replace the cover:

1. Replace water distributor box cover gasket.
2. Install the cover over the bolt studs.
3. Install the four (4) cover retaining rings sections and nuts.
4. Tighten the wing nuts firmly to prevent foreign materials from entering the water box.

Note: The freezer cover and gasket are not intended to hold the pressure of the circulating water in the event of a freeze up. Therefore every effort should be made to prevent the Tube-Ice[®] from freezing solid (with no hole).

Tube Size	1 1/2"	1 1/4"	1"
Hole Size	1/4"-3/8" Avg.	1/8"-3/16" Avg.	1/16"-1/8" Avg.

TABLE 7-2
Average Hole Size In Tube-Ice[®]

Water Tank. The production of opaque ice can indicate that the water in the water tank contains a concentrated amount of solids or salts. See Troubleshooting, "Poor Ice Quality".

To clean the water tank:

1. Stop the machine at the end of harvest.
2. Shut off the make-up water supply.

3. Open the drain valve and drain the tank.
4. Remove the water box cover and flush out any loose sediment from the tank. The wire mesh screen can be removed if necessary.
5. If further cleaning is needed, follow “Cleaning Procedure”.
6. If further cleaning is not needed, close the drain valve and refill the tank with fresh water.
7. Make sure the float valve is adjusted properly and install the water box cover.
8. Start and stop the pump again to make sure it is circulating water and is not air bound.

Water Cooled Condenser Cleaning (optional). As water evaporates from a cooling tower, the solid impurities remain and must be flushed from the system to prevent a scale build-up in the condenser and cooling tower. This can be accomplished by a continuous bleed off valve located in the pump discharge line. The valve should be adjusted to bleed off an equal amount of water which is evaporated. If water hardness is very high, a higher bleed off rate or chemical treatment may be required. Consult you local water treatment company for recommendations.

If after a period of time, scale has formed inside the tubes, mechanical cleaning may be necessary. See “Servicing Section--Condenser”.

Cooling Tower/Evap Condenser (optional).

1. Bleed off valve. The bleed off valve should be checked monthly to assure that is not blocked and that water is flowing as required. If the unit is controlled by a water treatment system, the bleed off valve may not be required.
2. Strainer. The pan or sump strainer is located in the bottom of the sump at the suction connection to the pump. The strainer should be inspected monthly and kept clean. Do not operate the unit without the strainer in place.
3. Make-up water float valve. This valve should be checked monthly for proper operation and adjustment. It should be adjusted to maintain a water level below the overflow and high enough to prevent the pump from cavitating when the system is in operation.
4. Spray nozzles. The spray nozzles should be checked monthly to make sure none are restricted and the spray pattern is complete and even.
5. Pump motor and fan motor. The motors should be checked and/or lubricated every six months according to the motor manufacturer’s recommendations.
6. Fan bearings. The fan bearings should be lubricated every six months. Make sure the proper grade of grease is used (normally conforms to NLCI-Grade 2) and it is best to use a hand grease gun.
7. Fan belts. The fan belt tension should be checked weekly for the first two weeks of operation, then monthly during continuous use.

The best tension for a V-belt is the lowest tension at which the belt will not slip under its full load. Never use dressing on V-belts. Keep belts and grooves clean and free of oil, grease, and foreign material. Clean with non-flammable, non-toxic degreasing agent or commercial detergent and water.

! CAUTION !
Follow all lock-out and tag-out procedures before servicing any electrical equipment.
! CAUTION !

Service/Frequency	Start-Up	Monthly	Six Months	Shutdown
Clean debris from unit	X	X		X
Clean strainer and flush sump	X	X		X
Check fan and pump rotation	X			
Clean spray nozzles	X	X		
Check belt tension	X	X		
Check for noise/vibration	X	X		
Check/adjust make-up water valve	X	X		
Check/adjust bleed rate	X	X		
Check/lubricate fan bearings	X		X	
Lubricate motor base adj. screw	X		X	X
Drain sump and piping				X

TABLE 7-3
Cooling Tower Maintenance Schedule

Compressor (optional). This section is only a guide, please consult the compressor manual for manufacturers recommended maintenance.

In starting and charging the unit, the oil sight glass should be continually checked to make sure an adequate oil level is maintained. The oil level should be 1/4-3/4 of the sight glass. If the oil level drops below 1/4 of the glass, add refrigeration oil as per the compressor manufacturer recommendations. Never allow the oil level to be out of sight, above or below the sight glass when the compressor is operating.

! CAUTION !
The crankcase heater should be energized for a minimum of four hours and the oil temperature should be 100°-110°F before attempting to start the compressor.
! CAUTION !

During operation, the specified net oil pressure should be maintained for proper lubrication and operation of the cylinder unloader mechanism.

Mycom N&W Series net oil pressure: 17-28 psig

Vilter 450 Series net oil pressure: 35-50 psig

Note: Net oil pressure is calculated by subtracting the compressor suction pressure from the oil pressure gage reading while the compressor is running.

Example: Oil pressure gage reading: 65 psig
 Suction pressure gage reading: 40 psig
 Net Oil Pressure: 25 psig

The compressor oil should be changed at close intervals during initial break-in operation and up to the first 1000 hours (see Table 7-4 below).

Note: It is the owner's responsibility to make sure normal maintenance is initiated to insure that the compressor is not subjected to premature wear or failure due to neglect or lack of sufficient maintenance and care.

	Frequency				
	1st	2nd	3rd	4th	Thereafter
Change oil	200 hr.	500 hr.	1500 hr.	4000 hr.	every 4000 hrs.
Clean suction strainer cloth	200 hr.	500 hr.	Remove if clogging is minimal		

TABLE 7-4
Compressor Maintenance

The above maintenance is only a guide. The compressor should be inspected anytime there is unusual noise, damage is suspected or the oil becomes discolored. The oil should be changed any time the compressor is opened. For specific recommendations and instructions, refer to the particular compressor manufacturer's manual. See "Compressor Oil Changing and Inspection"

Oil Trap. Although the compressor is equipped with an oil separator which has an automatic return, some oil will pass through the separator and eventually settle in the oil trap (36), which is offset from the base of the freezer. This oil trap will have evidence of frost on its surface during the freeze cycle and may be more pronounced at the end of a normal freeze cycle just before the harvest. Where there is oil in the trap, there will not be frost. Where there is frost, there will not be oil. When the trap is 1/2 to 3/4 full of oil, it should be drained.

The machine should be shutdown for at least 12 hours before attempting to drain oil from the trap. Follow the procedure outlined in the service section, "Draining Oil Trap".

! CAUTION !
Only qualified refrigeration service personnel familiar and experienced in the handling and use of anhydrous ammonia (R717) should be authorized to perform the "Draining Oil Trap" procedure.
! CAUTION !

Cutter Gear Reducer. The oil level of the gear reducer should be checked monthly or when there is any evidence of leakage. The correct level is indicated by the pipe plug in the side of the gear housing. The oil should run out of the hole when the plug is taken out. If low, add oil through one of the top plugged holes. A high grade lubricant such as Mobil 600W or SAE 140 gear oil should be used. The oil should be changed annually. Drain the oil and flush the gear case with mineral spirits. Drain the mineral spirits completely and refill with the proper oil.

Note: If a USDA high food grade lubricant is desired, use Chevron FM Lubricating Oil 460X.

! CAUTION !
Follow all lock-out and tag-out procedures before servicing any electrical equipment.
! CAUTION !

8. Troubleshooting

Note: Your machine's electrical system has several built-in safety and overload protection features to stop operation when a single component fails or there is a problem from an outside source such a power supply. Make sure all auxiliary equipment is connected to incorporate safety and overload circuits and protect all related equipment.

When the machine stops, it must be manually restarted by pushing the "Start" button. If it stopped while in a freeze cycle, it should be manually harvested to remove all ice from the freezer. This is done by pushing the white "Manual Harvest" button.

Always check the machine operation thoroughly after remedying the problem. Be sure to correct the source or cause of the problem to prevent the problem from occurring again.

<u>Symptom</u>	<u>Page</u>
Machine stopped	8-2
Freeze-up due to extended freeze period	8-4
Freeze-up due to ice failing to discharge	8-5
Low ice capacity	8-6
Poor ice quality	8-7
High discharge pressure	8-8
Low discharge pressure	8-9
High suction pressure	8-9
Compressor running unloaded during freeze	8-9
Compressor oil pressure low	8-10
Compressor loosing oil excessively	8-10
Machine short cycles	8-11
High compressor discharge temperature	8-11
Suction line frosting to compressor	8-12

Contact your distributor first for technical service assistance about operation problems not covered in this manual.

Also feel free to contact the factory for additional service (502) 635-3235.

TROUBLESHOOTING

Symptom: Machine Stopped

Possible Cause	Possible Remedy
Power failure or interruption	Check fused disconnect or circuit breaker supplying power to the machine. If power has been off, make sure the crankcase heater is energized and there is no liquid refrigerant in the compressor crankcase prior to restarting the compressor. If ice is in the freezer, initiate a manual harvest.
Circuit breaker (CB4) for control circuit tripped	Check compressor crankcase heater, coils of relays, contactors, starters, solenoid valves, and thawing timer for a ground. Repair or replace any defective part and reset circuit breaker. Make sure there is no liquid refrigerant in the compressor crankcase prior to restarting the machine.
Compressor motor starter overload tripped	Check for a loose connection on all motor starter and motor terminals which could cause excessive amp draw. Reset overload and restart the machine, check amperage, power supply, and head pressure. (Check delay timer in part wind starts only).
Water pump, cutter motor, conveyor motor, overload tripped	Check for loose connection on all terminals which could cause excessive amp draw. Reset the overload and manually run that particular motor to check actual voltage and amperage against motor rating.
Freezer water pump motor overload (2MOL) tripped	Check for loose terminal connections and/or defective breaker (CB2), reset the overload and start the pump by turning the selector switch (1SS) to "Hand". Check voltage and amperage against motor rating. Confirm proper rotation.
Cutter motor overload (3MOL) tripped	Check for loose terminal connections and blown fuse, reset the overload. Clear all ice that may have jammed cutter. Turn the selector switch (1SS) to "Hand" and push the "Manual Harvest" button. Check voltage and amps against motor rating. If tripping repeats but ice is not jammed, check the gear reducer for resistance, cutter bearings for wear, drive gear and ring gear for proper engagement, and reducer motor for defect or single phasing.
Bin level control (optional) open	Adjust or replace control as required. If bin level control is not used, make sure jumper wire #8 and #9 is installed at of the terminal block.

Symptom: Machine Stopped (con't)

Possible Cause	Possible Remedy
High/Low pressure safety switch (1PS or 4PS) tripped (optional)	<p>If the machine stops by low pressure cutout, the switch will reset automatically when the pressure raises to the “cut-in” setting. Check thaw gas valve (18) to make sure it opens during harvest time. Check Liquid feed valve (20) to make sure it is feeding during a freeze.</p> <p>If the machine stops by high pressure cutout, the switch will have to be manually reset after the pressure drops below the “cut-in” setting. Check the head pressure during the next freeze cycle.</p>
Low oil pressure tripped (OPS) located on compressor	<p>Manually reset the switch after the switch heater cools. Check the crankcase oil level (1/4-3/4 full). Add oil if below 1/4 glass before attempting to restart the machine.</p> <p>Restart the machine and check net oil pressure (net oil pressure = oil pump line pressure minus crankcase suction pressure).</p> <p>Net oil pressure range:</p> <p>Mycom = 17-28 psig Vilter = 35-50 psig</p>
Defective control panel component such as 1PB, 1SS, 1M contact, 2CR contact, 2TR	See FIGURE 6-3, Wiring Schematic, and check for open circuit. Refer to FIGURES 6-1 and 6-2, Control Panel to identify parts. Check for loose wires. Replace defective part, restart machine, check power supply, and current draw.
Circuit breaker (CB2 or CB3) for pump or cutter motor tripped.	Check for loose connection on all terminals, reset breaker and check amp draw against breaker rating. Check voltage and current unbalance, Section 3. Replace breaker if defective.

TROUBLESHOOTING

Symptom: Freeze-up due to extended freeze period

Possible Cause	Possible Remedy
Freeze timer (1TR) set to long	Adjust timer or replace if defective. See FIGURE 9-1.
Freezer pressure switch (2PS) set too low or defective (optional)	Adjust switch or replace if defective. See FIGURE 9-1.
Water tank drain valve, make-up water float valve or flushing valve stuck or opened (if 2PS is used)	Close, repair, or replace valve as needed. The float valve should be adjusted low enough that water should not run out the tank overflow during the freeze cycle.
Thaw gas solenoid valve (18) leaking through during freeze(if 2PS is used)	Check the manual opening stem to make sure it is in the automatic position (stem screwed in). Check for leakage by sound, temperature difference and frost during the freeze cycle. Leakage should stop by closing the hand stop valve downstream of thaw gas valve. Isolate and repair or replace the valve as needed.
Compressor running unloaded	<p>If the compressor is running unloaded, the motor amp draw will only be 60%-70% of the normal amp draw of a loaded compressor.</p> <p>Check the load delay timer electrical circuit to make sure the “UR-SOL” coil is not energized.</p> <p>Refer to the compressor manual for normal oil pressure needed to load the compressor cylinders and any further procedures to check the mechanical function of the unloader mechanism.</p>

Symptom: Freeze-up due to ice failing to discharge

Possible Cause	Possible Remedy
Freeze timer (1TR) set to long	Adjust timer or replace if defective. See FIGURE 9-1.
Extended freeze period (if 2PS is used)	Check freezer pressure switch (2PS) adjustment. See FIGURE 9-1 for adjustment and TABLE 7-2 for average hole size. Make sure all water distributors are in place (one in each tube).
Thaw time too short (2TR)	Adjust thaw timer (2TR) to allow all ice to clear the cutter and ice discharge opening with at least 30 seconds to spare. Replace defective timer. See pressure regulating valve adj.
Thaw pressure too low	The thaw gas regulator should be adjusted to increase the pressure in the freezer to 60-65 psi during a harvest. Isolate and repair or replace the valve as needed.
Insufficient heat for thawing due to low condensing pressure	The head pressure should be maintained from 175-190 psi (maximum 200) usually by a water regulating valve or fan cycling switch. Check to make sure these controls are working properly. Cold prevailing wind can also be a factor.
Insufficient heat due to non-condensables (usually air) in the system	If non-condensables are present with the refrigerant, the saturated temperature will not relate to the pressure reading at the receiver and the refrigerant will be cooler, although pressure will be high. Air can be purged from the system by following the procedure in the Section 9, "Purging Non-Condensables".
Insufficient heat due to low refrigerant charge	The refrigerant level in the receiver should be near the operating mark at the end of a freezing cycle to provide enough volume of warm gas for harvesting. DO NOT OVERFILL RECEIVER. See Table 3-2
Cutter or cutter disc does not turn	Check cutter gear reducer and drive gear for proper operation and alignment. Check for broken gear teeth or sheared shaft key. Replace defective parts.
Compressor not running unloaded during thaw cycle. (for dedicated high side only)	Check compressor motor Amp draw. During the thaw cycle, the compressor motor Amp draw should be 60 - 70% of normal amp draw during the freeze cycle. Check compressor unloader solenoid coil (UR) to make sure it is energized and the valve opening during the thaw cycle.

TROUBLESHOOTING

Symptom: Low ice capacity.

Suspicious of low ice capacity should be confirmed by accurate calculations of actual ice product. Much weight can be lost by melting and off fall through augers and other ice handling equipment.

1. Time the total freeze and thaw cycle for the cycle which is to be caught and weighed.
2. Catch all the ice at the ice discharge opening of the machine.
3. Weight the total amount of ice caught.

Lbs. ice per cycle

Cycle time minutes X 1440 = _____ lbs. production per 24 hours

More than one cycle should be caught and weighed to get an accurate average.

Possible Cause	Possible Remedy
Inadequate water for ice making	Water pressure of 40 psig minimum is required to assure proper water supply. Check water pressure. Check for a restriction in the incoming line or at the make-up water float valve.
Water distributors may be stopped up	Check distributors and clean orifices as needed.
Freeze timer, Freezer pressure switch or thaw timer out of adjustment	Check hole size in Tube-Ice (See TABLE 7-2). Crushed ice should be 3/16"-1/4" thick. Check and adjust thawing time. Thawing should be 30 seconds longer than it takes for all the ice to clear the freezer.
Excessive ice chips in the water tank, causing short cycling	Check incoming water temperature (45°F minimum). Check flushing valve to make sure ice chips are being melted and flowing out the tank overflow during the harvest cycle.
Compressor running unloaded or not pumping full volume	Check compressor motor amp draw. Check for belt slippage and tighten as needed. Check for leaking compressor suction or discharge valves. Refer to your compressor manual. See other related symptoms.
Restriction in the refrigerant liquid line or float switch not operating properly	Check for a partially closed valve or an obstruction at the strainer, solenoid valve, or hand expansion valve. The liquid line will normally have frost on the downstream side of a restriction, especially as the suction pressure decreases.
Low refrigerant charge, causing re-freeze	Check the receiver gage glass mark for the proper level. Check for and repair leaks. Add refrigerant.
Warm make-up water for ice making	Capacity of the machine is proportional to ice making water temperature. Warmer water will reduce the ice making capacity. Refer to Section 10, Capacity Table. Check float adjustment and water tank drain valve.

Symptom: Low ice capacity (cont.)

Possible Cause	Possible Remedy
Excessively high head pressure	Check cooling tower or evap condenser to make sure sufficient water is provided for cooling and the equipment is operational to cool the water. Also see "Symptom High Head Pressure".
Suction regulator out of adjustment or defective (optional)	Check the freezer pressure and compare to the main suction pressure. The suction regulator should regulate the freezer pressure and create a 2 psi pressure drop across the valve. Adjust pressure regulator. Repair or replace defective valve.
Thawing gas solenoid valve (18) leaking through during freeze cycle	Check the manual opening stem to make sure it is in the automatic position (stem screwed in). Check for leak by sound, temperature difference and frost during a freeze cycle. Close the stop valve (90) to confirm suspicion of leakage. Repair or replace the valve.

Symptom: Poor ice quality

Possible Cause	Possible Remedy
Excessive concentration of solids in the water tank usually indicated by a build-up of mineral deposit on the sides and bottom of the tank and opaque ice production. Also, water distributors restricted.	Perform a cleaning procedure as well as removing the freezer cover and cleaning the water distributors. Make sure the flushing valve (63) is functioning and the tank overflow piping is not restricted.
Insufficient water supply indicated by a low level in the tank	Check water pressure, 40 psig is recommended minimum. Check for a water line restriction, partially closed valve, or defective make-up water float valve. Make sure the water tank drain is closed.
Water pump rotation wrong direction	Check rotation in relation with arrow on pump housing and reverse two wires at the motor if necessary.
Low refrigerant charge, causing an ice out problem and re-freeze	Check refrigerant level mark on the receiver and on the painted portion of the gage glass guard. Be sure to keep the gage glass cocks closed when finished checking the level.
Suction Pressure to low	Adjust suction regulator valve
Restriction in liquid line, causing short freeze cycle	Check for closed valve, defective solenoid valve (20), float switch defective or strainer restricted. The liquid line will normally have frost on the down-stream side of a restriction, especially as the suction pressure decreases.

TROUBLESHOOTING

Symptom: High discharge pressure (check gage accuracy)

Possible Cause	Possible Remedy
Insufficient water flow through the cooling tower or condenser	Check the condenser water pump to make sure it is pumping enough water as specified in TABLE 3-2. Check sump strainer screen and clean. Check condenser pump direction of rotation.
Fan control out of adjustment	Check adjustment. Replace if defective.
Non-condensable in system.	If non-condensables are present with the refrigerant, the saturated temperature will not relate to the pressure reading at the receiver. The refrigerant will be cooler, although the pressure will be high. Air can be purged from the system by following instructions in Section 9, "Purging Non-Condensables".
Cooling tower or evap condenser in need of maintenance	Check fan motor and fan belts for proper operation and tension. Check spray nozzles, tubes, sump, and sump screen, for accumulation of mineral deposit and clean as required. Check tower blowdown and chemical treatment if applicable.
Dirty condenser tubes	Visually inspect the condenser tubes to see if there is any build-up of mineral deposit which would reduce the cooling effect of the tubes and water. Clean chemically or mechanically as applicable.
Too much liquid in condenser covering tubes causing inefficiency	Remove refrigerant so all tubes will be above liquid refrigerant level.

Symptom: Low discharge pressure (check gage accuracy)

Possible Cause	Possible Remedy
Fan cycling switch out of adjustment or defective	Check adjustment. Replace if defective.
Compressor running unloaded or not pumping efficiently	Check compressor motor amp. If the compressor is running unloaded, the amperage will only be approximately 60% of normal amp draw (FLA). Refer to the compressor manual.
Ambient temperature low and prevailing winds blowing through tower	Shield tower from prevailing winds to prevent excessive cooling. Install an indoor sump.
Too much cold water circulating through condenser	Install a water regulating valve in the water line from the condenser and control flow by receiver pressure.
Thaw gas valve #18 leaking through	Make sure manual opening stem is in the automatic (screwed in) position. Repair or replace defective parts.

Symptom: High suction pressure (check gage accuracy)

Possible Cause	Possible Remedy
Compressor running unloaded or not pumping efficiently	Check compressor motor amp. If the compressor is running unloaded, the amperage will only be approximately 60% of normal amp draw. Refer to the compressor manual.
Thaw gas valve #18 leaking through	Make sure manual opening stem is in the automatic (screwed in) position. Repair or replace defective parts.
Suction Pressure too low	Adjust suction regulator valve
Defective gage	Check pressure with accurate gage and replace as necessary.

Symptom: Compressor running unloaded during freeze (dedicated compressor only)

Possible Cause	Possible Remedy
Low oil pressure	Check compressor net oil pressure. Net oil pressure = oil pressure gage reading less suction pressure. Mycom = 17-28 psig Vilter = 35-50 psig. Refer to the compressor manual for "Oil Pressure Adjustment".
Unloader solenoid valve open	Check solenoid coil to make sure it is not energized. If valve is stuck open, replace valve.
Unloader mechanism not working properly	Refer to compressor manual. Mycom compressor can be loaded manually.

TROUBLESHOOTING

Symptom: Compressor oil pressure low (check gages)

See Section 7, for compressor oil pressure requirements.

Possible Cause	Possible Remedy
Oil diluted with refrigerant	Oil will be very foamy. Check liquid feed control for overfeed problem.
Oil pressure regulating valve out of adjustment	Adjust valve to increase oil pressure. Turn stem in to increase, out to decrease.
Compressor rotation incorrect	Check rotation direction by arrow indication. Reverse rotation, if necessary.
Restriction strainer, oil filter, pick-up tube or oil passage	Clean strainer or restriction in passage or replace filter.
Compressor thrust bearing installed upside down	The Mycom compressor thrust bearing on the shaft seal end has an oil passage hole which has to be in the proper position when installing the thrust bearing. Hole up for "WA" and "WB" series Mycom compressor. Refer to your compressor manual.

Symptom: Compressor loosing oil excessively

Possible Cause	Possible Remedy
Non-effective oil separator or float	The oil separator will normally return a good portion of oil leaving the compressor, if it is working properly. Check the oil float and return line to see it is not restricted.
Liquid refrigerant in crankcase	Check liquid feed to make sure it is not overfeeding and that the solenoid valve #20 is not leaking through when the machine is stopped.
Compressor piston rings seized or broken	Check compressor efficiency. If rings are seized or broken, replace defective parts.
Leaking shaft seal	A few drops per minute is okay. If ammonia is leaking, replace the seal.

Symptom: Machine short cycles (using freeze pressure switch (2PS) only)

Possible Cause	Possible Remedy
Freezer pressure switch (2PS) set too low or defective	Adjust switch or replace if defective. See FIGURE 9-3.
Freeze-up	See “Freeze-up due to extended freezer period” and “Freeze-up due to ice failing to discharge”.
Clogged water distributors	Clean water distributors.
Lack of water for making ice	Check water tank for sufficient water level. Check for restriction in water line, defective float valve, open drain valve, excessive ice chips or low water pressure and correct.
Lack of sufficient liquid refrigerant feed	Check float and float switch, solenoid valve and coil #20 in liquid line, strainer, and refrigerant level in receiver.
Water pump rotation incorrect or pump defective	Check pump motor rotation. Check for leaking pump seal or defective motor and repair or replace as needed.

Symptom: High compressor discharge temperature

Possible Cause	Possible Remedy
High head pressure	Check gage accuracy and “High discharge pressure”.
Defective suction or discharge valves	Feel the compressor heads for hot spots or one head running hot. Replace worn or leaking valves.
Restriction in the discharge gas line	Check all hand and check valves to make sure they are fully opened and not stuck. Repair or replace as needed.
Internal relief valve leaking	Check the compressor manual to see if your compressor is so equipped. Replace accordingly.

Symptom: Suction line frosting to compressor

Possible Cause	Possible Remedy
Liquid refrigerant overfeed	Check float switch to make sure it is functioning properly. Replace if defective. Check solenoid valve #20 to make sure it is not leaking through. Repair or replace if defective.
Refrigerant contaminated with water	Test refrigerant or oil for water contamination. Completely pump the freezer out (pumpdown) and blow excess water out through the oil trap drain valve #61. Refer to Service, Section 9 “Removing Excess Water”.

TROUBLESHOOTING

9. Servicing Operations

Automatic Blowdown (harvest cycle). A feature of this machine is a solenoid activated flushing valve (63) which is provided to eliminate or reduce the necessity for frequent flushing or cleaning of the water tank. This flushing during the harvest cycle helps to remove salts or solids accumulated in the water as a result of the freezing action. It also helps melt ice chips which fall into the water tank during harvest. The flushing valve is opened (energized) during each thaw cycle when the water pump stops and the water in the freezer tubes returns to the water tank. If water quality is superior, this blowdown can be reduced by installing a smaller reducer bushing in the outlet elbow.

The flushing action carries accumulated salts, solids, and ice chips (fines) out through the water tank overflow pipe. This overflow should be kept open at all times to allow the water to drain freely and keep the water level below the cutter disc and ice discharge opening. If the flushing solenoid valve leaks through during the freeze cycle, it can be disassembled and cleaned, then reassembled.

Cleaning Ice Making Section. Refer to Section 7, Maintenance for instructions for cleaning the circulating water tubes, water distributors, and water tank.

Float valve (make-up water). The make-up water float valve (12) maintains the proper pumping level in the water tank for ice making. The valve should be set to maintain a water level in the water tank during the freezing period, so that there will be a quantity of blowdown only during the thaw mode. The water level during the freeze mode should always be below the overflow piping to prevent excessive waste of cold water, resulting in loss of ice capacity.

If it should become necessary to clean the float valve, close the stop valve in the make-up water line to the machine and remove the float valve. After the valve has been cleaned and reinstalled, check to ascertain if the proper water level is being maintained. After the machine is stopped and the water in the tank seeks its normal level, there should be no water flow through the float valve or out the overflow.

It is advisable to install a large area strainer in the water supply line to protect the float valve from dirt or solids in the water which would necessitate frequent cleaning. A strainer of 40 mesh screen is usually satisfactory.

Float Switch. The float switch is installed on a header assembly that is attached to the freezer shell. Valves are provided for isolation of the float switch assembly if replacement or servicing is necessary. The float switch closes as the level of refrigerant in the freezer rises and opens as the level falls.

The float switch is connected to the "A1" solenoid valve coil. This is the solenoid valve directly before the hand expansion valve. Therefore when the refrigerant level in the freezer drops, the float switch closes, thereby energizing and opening the "A1" liquid feed solenoid until sufficient level has been reached to open the float switch. The float switch has a fixed 1/2" differential.

The float switch is installed at the correct height at the factory and should not need to be adjusted. The float switch is installed at the position which provides highest capacity. The correct height will produce compressor superheat which climbs throughout the freeze cycle to a minimum of 30° F.

SERVICING OPERATIONS

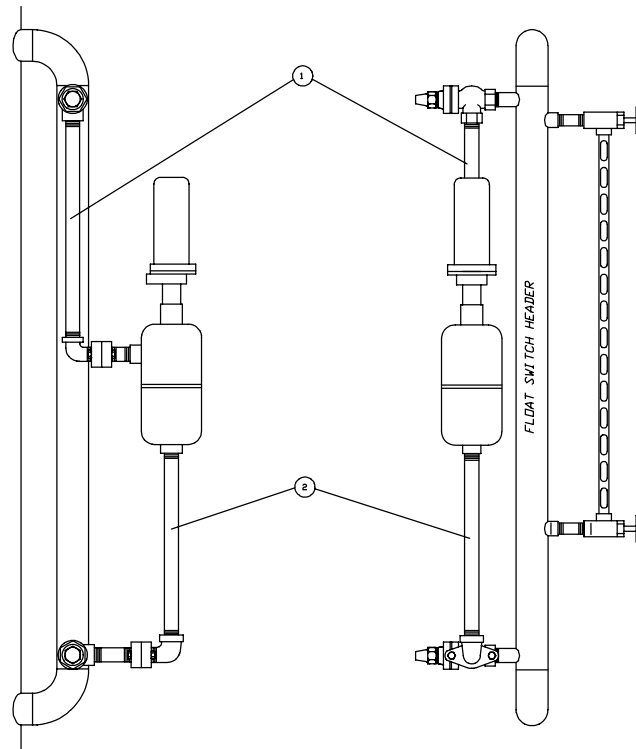

Figure 9-1
P24AL and P34AL Float Height

Model	Tube Size	1- Length of Pipe	2- Length of Pipe
P24AL	1"	12 3/4"	26"
P24AL	1 1/4" and 1 1/2"	18"	23"
P34AL	1"	12 3/4"	23"
P34AL	1 1/4" and 1 1/2"	18"	16"

TABLE 9-1
Length of Pipe on P24AL and P34AL Float Switches

Hand Expansion Valve. The hand expansion valve is located directly after the "A1" solenoid valve. This valve should be set at a point where the float switch is open for a length of time approximately equal to the time it is closed.

Freeze Timer. The freezing time period for producing ice of a desired thickness is controlled by the freeze timer (1TR), Figure 9-2, located inside the control panel. This timer is a microprocessor based timer housed in a standard 15 terminal CYCL-FLEX[®] plug-in case. Time set points are entered into the unit using a sealed membrane keypad on the front of the unit. Each digit in the setpoint is individually increased or decreased by pressing the appropriate keypad switch. There is a mode annunciator in the display area on the front of the unit. The mode annunciator will flash when the unit is timing. Table 9-2 shows the miniature rocker switch settings for the unit. This enables the unit to pulse output, reverse start, minute/second display and battery back-up setpoints and timing.

Switch	#1	#2	#3	#4	#5	#6	#7
ON	X	X	X			X	X
OFF				X	X		

TABLE 9-2
Miniature Rocker Switch Settings for Freeze Timer

Entering and Displaying Setpoints. Whenever the freeze timer unit is powered up and the previous setpoint has been lost, the digit display indicates four hyphens. The unit will not operate until it has been provided with a setpoint, clearing the display of hyphens.

To create or change a setpoint, press the SET key. The setpoint if any, is displayed and the panel key pads become active. The operation of the timing or counting function and the output loads are not affected. For setpoint changes, the SET indicator appears on the graphics panel. The setpoint is changed by pressing appropriate Δ or ∇ key pads. Pressing a Δ key increments the setpoint digit located above the key; the ∇ key decrements the digit located above the key. If the pad is continually depressed, the digit will change every .5 second until the pad is released. The display will carry to the digit on the left on the 9 to 0 transitions when using the Δ pads. The display will borrow from the digits on the left on the 0 to 9 transitions when using the ∇ pads. On ranges 6 and 7, the display will carry on the 59 to 00 transition and borrow on the 00 to 59 transition of the two least significant digits.

When the desired setpoint is displayed, touch the ENT key. The new setpoint is entered, all Δ and ∇ keys become inoperable and “SET” disappears from the graphics panel. New setpoints can be entered while the unit is timing or counting, but they will not take effect until the next reset.

The setpoint may be displayed at any time without disturbing the timing or counting cycle by pressing SET. The actual value is returned by pressing ENT. If the unit is set at 0000, the load is always ON if programmed for OOX, and always OFF if programmed OXO.

A keypad “lock” is provided on the freeze timer to prevent unauthorized tampering. To initiate the keypad lock, press the word “SIGNAL” in the Eagle Signal logo for 8 seconds. To disable the lock to change setpoints, remove power from the unit and turn the battery off (miniature rocker switch #6) and then on. The unit will lose all setpoints and they must be re-entered for further operation.

SERVICING OPERATIONS

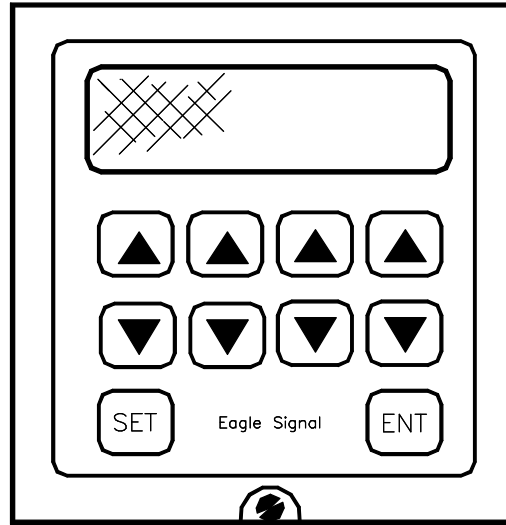

FIGURE 9-2
Freeze Timer (1TR)

Freezer Pressure Switch (optional). The freezing time period for producing ice of a desired thickness is controlled by the freezer pressure switch (2PS), Figure 9-3, located inside the control panel.

The original switch was set at the factory to produce ice of recommended thickness. Look at the “Certificate of Test” which was provided with the machine for a sample set of pressure readings with corresponding time periods and water temperatures. Also see TABLE 11-8/ 11-9, Operating Vitals for typical settings. When making adjustments, allow two ice discharging cycles between adjustments. Switch adjustment is as follows: See Figure 9-3.

1. Turn the low signal adjustment nut CCW until low signal setting indicator is fully down. Turn the high signal adjustment nut until high signal setting indicator is slightly beyond the actuation setting of 55 psig.
2. Starting with the pressure above the actuation pressure, reduce the pressure to desired actuation pressure of 55 psig, contact opens.
3. Advance the low signal adjusting nut until the switch actuates and contact closes.

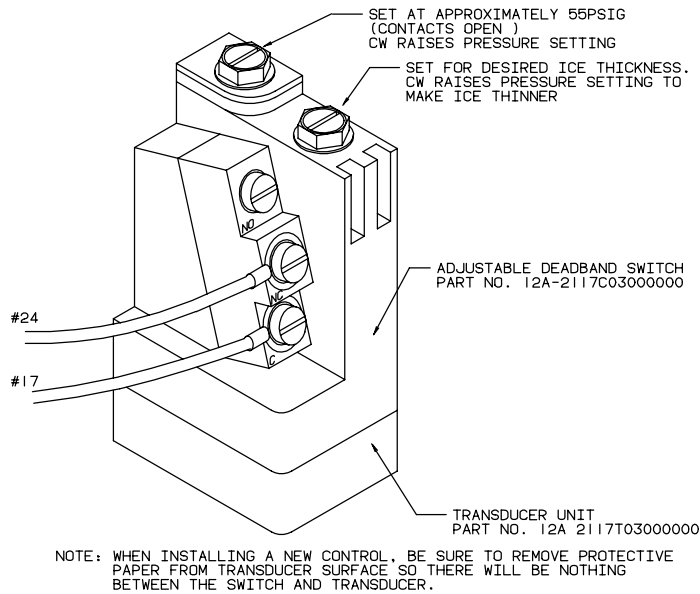

FIGURE 9-3
ASCO Freezer Pressure Switch (2PS)

It is preferable that the freezing cycle be such that a small diameter hole remain in the center of the ice cylinder (1/16" diameter for 7/8" diameter ice, 1/8" diameter for 1 1/8" diameter ice, 1/4" diameter for 1 3/8" diameter ice). This insures that the freezing cycle is not extended unnecessarily and eliminates a possible opaque core in the center of the ice, as well as a loss of production.

Control Circuit Protection. The electrical control circuit of the machine is protected by a 6 amp circuit breaker (CB4). If this breaker should open, the machine will immediately stop. Before resetting the circuit breaker, open the disconnect switch and lock-out all power to the control panel. Reset CB4 and restore power. Check circuitry with a volt meter. If the machine was off for an extended time, the crankcase heater must be energized for a minimum of four (4) hours and no liquid refrigerant in the crankcase before restarting the machine. When ready to restart the machine, depress the "Start" button. As usual, initiate a harvest cycle if there is ice remaining in the freezer. Check Amp draw through the breaker for excessive load or unbalance.

Thawing Timer. The thawing timer (2TR), Figure 9-4, governs the ice thawing period. It is located inside the control panel (FIGURE 6-1). It is started by action of the freeze timer (2TR) or freezer pressure switch (2PS) which energized the "1CR" relay. This timer is set prior to shipment for approximately a three minute period. To replace the timer, simply pull the timer from its base and plug in another, set to "X1" and "Min" and set the thawing period for at least 30 seconds longer than the time required to harvest the entire discharge of ice. If it should be necessary to change the setting of the timer, turn the adjustment dial clockwise to increase the time or counter-clockwise to decrease the time. Check thaw time after each adjustment.

Note: Thicker ice may require a longer thaw period, due to slower ice release time.

SERVICING OPERATIONS

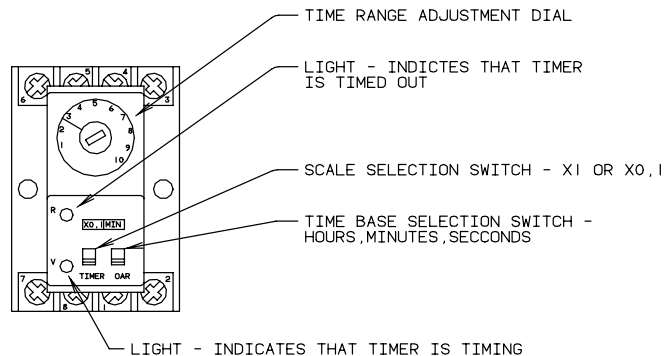

FIGURE 9-4
Thawing Timer (2TR)

Suggested Condenser Cleaning. Any brush or cleaning tool should be sized accordingly so as not to damage the tubes during cleaning. The cleaning tools should be rotated at the specified speed for the particular tool used. The tubes should be kept wet during cleaning. After cleaning the tubes should be flushed thoroughly and all foreign material removed. Contact your distributor or Vogt's Service Department to obtain the proper cleaning tools.

The following is the condenser cleaning procedure:

1. Make sure ample room is provided for removing the condenser heads and using the mechanical cleaning equipment.
2. Order replacement cover gaskets for use at the time of reassembly.
3. Disconnect and lock-out power to the ice machine, compressor and auxiliary equipment.
4. Disconnect water piping and drain the condenser. Generally additional water can be drained by loosening the cover (heads) and separating the covers from the condenser end.
5. Remove the heads bolts and gasket completely.
6. Inspect the tubes for excessive corrosion and possible ammonia leaks to determine whether or not further cleaning is feasible.
7. Clean the inside of each tube as well as possible, being careful not to damage the tube. Follow the instructions for the particular tool being used.
8. Flush each tube with water to remove all loose material to prevent contamination of the cooling tower and sump.
9. Clean the ends of the tube sheets, so the new gasket will seal properly.
10. Install the replacement gasket. Make sure the gasket does not cover the tube ends.
11. Install the end covers (heads) and fasten securely in place with the head bolts. It is recommended that an anti-seize compound be applied to the bolt and nut threads to prevent rusting and ensure ease of removal at the next cleaning.
12. Reconnect the water piping, turn on the power. Check for leaks by turning the power on to the condenser pump allowing it to run.
13. Turn the power ON to the compressor and wait for the crankcase heater to warm-up the compressor before starting the machine.

Cutter Gear Reducer. The cutter motor and gear reducer (54), Figure 9-5B, drive the ring gear of the cutter assembly. It is important that the teeth of the drive gear and the ring gear mesh properly both vertically and horizontally. The drive gear and hub can be raised or lowered on the gear reducer shaft to obtain maximum vertical tooth engagement and the reducer assembly can be moved in or out horizontally to obtain the proper tooth depth for maximum gear life.

Note: The motor and gear reducer are an integral unit. Only qualified personnel should attempt to disassemble and repair this unit.

Drive Gear Replacement.

1. Disconnect and lock-out all power to the machine.
2. Remove the top and side bolts holding the mounting plate to the support bracket. Lift the plate and gear reducer from the bracket and rest the assembly on a stable work table sitting next to the tank. Leave the electrical conduit connected to the gear reducer motor.
3. Inspect the drive gear teeth for proper vertical alignment and wear pattern.
4. If the wear pattern indicates less than a full width of tooth engagement, measure the difference and make a note to correct at the time of reassembly.
5. Measure and record the dimension from the drive gear to the bottom side of the mounting plate.
6. Remove the three or four cap screws holding the drive gear to the split taper bushing.
7. Using two of the same cap screws in the threaded holes of the bushing, jack the gear off the bushing and remove both from the gear reducer shaft.
8. Clean the split bushing and tapered hole of the new drive gear and insert the bushing into the drive gear making sure the tapers match.
9. Slide the split hub and gear onto the keyed shaft with the key in place, positioning the hub (by measurement previously recorded) so the full width of the gear teeth will engage when assembled and tightened.
10. Tighten the cap screws (three or four) progressively and uniformly around the hub and recheck the location measurement. If it is not correct, loosen the cap screws, hub and gear assembly and make correction. Then retighten the cap screws.
11. Install the reducer and mounting plate assembly on the water tank bracket and fasten in place with the side and top cap screws.
12. Rotate the cutter and disc assembly by hand and stop at the point where you feel the least amount of backlash between the gear teeth.

NOTE: There should be only a slight amount of backlash (more specifically “tooth tip clearance”). Too much clearance will cause premature wear and possible tooth damage. When the cutter runs under a no load condition, it should have a smooth uniform sound. For

SERVICING OPERATIONS

lubrication, see Section 7, Maintenance.

13. If the tooth tip clearance needs adjusting, loosen the four hex nuts holding the reducer to the mounting plate and move the reducer as required for proper tooth engagement. Tighten the hex nuts securely and recheck backlash.

Gear Reducer Replacement.

1. Disconnect and lock out all power to the machine.
2. Disconnect electrical wires and conduit from the motor.
3. Remove the top and side bolts holding the mounting plate to the support bracket and lift the plate and gear reducer assembly from the tank bracket.
4. Inspect the drive gear teeth for proper vertical alignment and wear pattern. If the wear pattern indicates less than a full width of tooth engagement, measure the distance so correction can be made at the time of reassembly.
5. Measure and record either the distance of the drive gear from the mounting plate or the split hub from the shaft end for future reference when reassembling.
6. Remove the three or four cap screws from the split taper bushing.
7. Use two of the cap screws in the threaded holes of the busing as jacking screws for pushing the drive gear from the hub.
8. Drive a wedge in the split of the hub (bushing) and slide both the hub and gear from the shaft.
9. Remove the four hex nuts and lock washers from the carriage bolts around the reducer base and mounting plate and separate the plate and reducer.
10. Install the replacement gear reducer and motor onto the mounting plate using the carriage bolts, lock washers, and hex nuts. Tighten the nuts snug only for later adjustment.
11. Clean the split hub and drive gear, insert the hub into the gear, making sure the tapers of the two match and slide the hub and gear onto the shaft.
12. Position the hub on the shaft (note measurements previously taken) so the full width of the gear teeth will engage when assembled and tightened.
13. Tighten the cap screws (three or four) progressively and uniformly around the hub, checking the measurements and adjusting as necessary.
14. Install the reducer and mounting plate assembly on the water tank bracket and fasten in place with the side and top cap screws.
15. Rotate the cutter and disc assembly by hand and stop at the point where you feel the least amount of backlash between the gear teeth.

16. If the gear tooth tip clearance needs adjusting, loosen the four hex nuts around the reducer base and move the reducer as required for proper tooth clearance. Tighten the hex nuts securely and recheck for backlash.
17. Reconnect the electrical wires and conduit to the motor.
18. Check cutter rotation and correct as necessary.

NOTE: When the cutter runs under a “no-load” condition, it should have a smooth uniform sound.

The weights listed in TABLE 9-1 will give you an idea of manpower or equipment needed when servicing and handling the various parts of the water tank and cutter. Be sure to use safe lifting and handling practices to prevent bodily injury and/or damage to parts. If additional information is needed, you should contact your distributor or the factory.

To inspect the cutter assembly and make repairs or replace parts, it will be necessary to lower and remove the water tank from its mounting to the bottom of the freezer. The water tank has metal casters allowing it to be rolled out from under the freezer for inspection and servicing.

Description	Weight (lbs.)	
	P24	P34
Water tank (bare)	333	428
Bearing bracket assembly and cutter disc	106	150
Cutter assembly and ring gear	89	164
Water tank and cutter assembly	528	742
Cutter disc	57	97
Cutter drive gear	8	14
Gear reducer and motor	56	96
Water pump	85	85

TABLE 9-3
Water Tank and Cutter Parts Weights

Water Tank Removal

1. Disconnect and lock-out all power to the machine.
2. There should be ample space to roll the water tank from under the machine. It may be necessary to provide a flat level surface such as a sheet of plywood sufficiently supported to hold the weight of the tank and cutter assembly. See TABLE 9-1.
3. Turn off water supply, drain water, and disconnect water and drain lines from the tank.

SERVICING OPERATIONS

4. Remove the overflow tubing from the water tank and remove the circulating water tubing from the pump.
5. P34A only - the water pump is mounted to the structural frame of the machine and will have to be disconnected from the tank at the pump inlet bolted flange before moving the water tank.
6. Disconnect the ice discharge chute or hopper from the ice discharge opening of the water tank, making sure the tank is free to be moved.
7. Remove the mounting bolts from around the flange of the tank, allowing the tank to be lowered to rest on its casters.
8. P34A only - the channel support at the right side base of the machine (opposite from the pump side) will have to be removed for the tank to be rolled out from under the freezer.
9. Roll the water tank from under the freezer, turning it as you go to clear the gear reducer and motor. It is now accessible for inspecting and/or repair of the cutter assembly.

Cutter Assembly Removal and Installation.

1. Follow water tank removal instructions, Steps 1-9. See Figure 9-5B.
2. Remove the socket head cap screw from the center of the cutter shaft and lift out the retainer and gasket.
3. Lift the cutter straight up and off the shaft, taking care to catch the shaft key as it is removed.
4. To install the cutter, lower it down onto the shaft, allowing the ring gear to mesh with the drive gear.
5. Rotate the cutter, aligning the shaft and hub key way and inserting the key to its full depth.
6. Install the gasket, the retainer, and the socket head cap screw and tighten to approximately 15 ft. lb. torque.
7. Check and adjust the cutter height per “Cutter Height Adjustment” instructions.

Bearing Bracket and Cutter Disc Removal.

1. Remove the cutter assembly per instructions.
2. Match mark the bearing bracket support arms with the water tank for reassembly reference.
3. Remove the splash shield and ice deflector plate from the ice discharge opening.
4. Support the bearing bracket to keep it from falling in the tank. Loosen and remove the four cap screws and lock washers from the ends of the bearing bracket support arms.

5. Lift the bracket and cutter disc from the tank. Be sure the support arms are match marked for reassembly. You may have to gently drive the support arms up or down to release them from the tank walls.
6. With the bracket and disc assembly turned upside down, remove the cotter pin from the shaft.
7. Loosen and remove the slotted hex nut, spring washer, and spacer.
8. Lift the cutter disc from the keyed shaft, being careful not to lose the shaft key.

The cutter shaft and bearings are sealed in the bearing bracket assembly. The cavity between the bearings has been filled with a food-grade grease to prevent the presence of moisture and prolong the life of the unit. If there is any vertical or side movement of the shaft or if the bearings feel rough or tight when turning the shaft, the assembly should be dismantled and rebuilt. Refer to the cutter tank assembly drawing, Figure 9-5B, for parts location and identification.

Cutter Shaft and Bearing Removal.

Note: Use only a soft mallet or other soft tool for fitting all parts into place.

1. With the bearing bracket assembly removed from the tank, press the shaft out of the housing from the bottom up.

Note: The two top bearings may come out with the shaft along with the upper seal and excluder.

2. Turn the bracket over and press the bottom bearing out the bottom, along with the lower seal.
3. There are three spacers on the shaft which should be removed and labeled as to their location. Remove them as they are made accessible.
4. Clean and inspect all parts for wear or damage. Discard all parts showing any indication of damage.

Cutter Shaft and Bearing Installation.

1. Clean the inside of the bearing housing of grease or foreign matter. Further clean the top bearing housing with pro-lock cleaner and primer (or a suitable substitute) and remove the pipe plugs from the side of the housing.
2. Apply a thin coat of Loctite[®] RC/609 retainer (or a suitable substitute) to the inner surface and bearing shoulder of the top of the bearing bracket.
3. Insert a bearing in the top housing and set it in place.
4. Clean the cutter shaft and press the top bearing onto the shaft.
5. Slide the upper bearing spacer on the shaft and begin driving the shaft down through the middle bearing of the housing. Do not start the top shaft bearing in the housing.

SERVICING OPERATIONS

6. Partially fill the housing with grease (MPG-2 or a USDA approved grease). Use enough to fill the area between the two upper bearings, forcing some out the pipe plug hole when the shaft and top bearing are seated.
7. Finish driving the shaft and bearing into the housing until it is firmly seated.
8. Turn the bracket and shaft upside down and fill the housing around the shaft with MPG-2 (or suitable substitute) grease.
9. Slide the lower bearing spacer over the shaft and into the housing.
10. With the top end of the shaft supported, install the lower bearing on the shaft driving it down into the housing firmly against the housing shoulder.
11. Slide the seal spacer (ridged end in, flat end out) and seal (open face out) onto the shaft together.
12. Uniformly tap the seal into the housing against its shoulder.

NOTE: The purpose of the seals and excluders are to prevent moisture from entering the housing area not to hold the grease in.

13. Wipe off excess grease and install the two pipe plugs.
14. Install the largest excluder on the bracket as illustrated by the assembly drawing.
15. Install the tines disc, the 1/4 x 1/4 key, spacer, spring washer, castle nut, and cotter pin.
16. Turn the assembly right side up and install it in the water tank, locating the support arms as they were match marked when removed and secure in place using the 5/8" stainless steel cap screw and lock washer maximum torque should be 90 ft. lbs.
17. Install the top seal (open side facing out*), tapping it uniformly into the housing until it seats.
18. Install the top water excluder.
19. Install the splash shield and ice deflector plate in the ice discharge opening.
20. Install the cutter assembly, using the 1/4" X 1/4" X 3 3/16" lg. stainless steel key to align the key ways and lock the cutter and shaft together.
21. Install the red rubber gasket, retainer, and 3/8" stainless steel socket head cap screw. Tighten to approximately 15 ft. lbs.
22. Check and adjust the cutter height per "Cutter Height Adjustment" instructions.

Cutter Height Adjustment. The height of the cutter can be adjusted by the four bolts holding the bearing bracket assembly in place. These bolts are threaded into holes in the end of each arm through holes in the water tank. The current design has these washers welded in place after the cutter height is properly adjusted. This helps to insure proper adjustment during servicing. Using a true straight edge long enough to reach across the top flange of the water tank (30" for P24 and 40" for

P34), the top of the cutter rim and blade should be $1/8'' \pm 1/16''$ below the top of the water tank flange.

Keep one end of the straight edge at the same point and swing the other end across the tank at various points to check the clearance.

Also, rotate the cutter to check all points. If adjustment is necessary, loosen the four side bolts and raise or lower each arm as needed. Tighten the bolts securely to approximately 90 ft. lb.

Water Tank Installation.

1. Place the $3/16''$ thick gum rubber gasket on the top of the tank flange. It can be held in place with narrow strips of tape through the bolt holes.
2. Push the water tank in and under the freezer aligning the bolt holes and installing the mounting bolts around the flange and tightening the nuts securely.
3. Reconnect the discharge chute or hopper to the ice discharge opening.
4. Mount the water pump (P34 only) and attach the circulating water tubing and overflow tubing.
5. Reconnect all water piping such as drain, overflow, and make-up water lines. Turn water on and check for leaks.
6. Fill the water tank with water and make sure the drain valve is closed.

When ready, turn the power "On" to the machine, but don't operate the compressor until the oil is warm and there is no liquid refrigerant in the crankcase.

SERVICING OPERATIONS

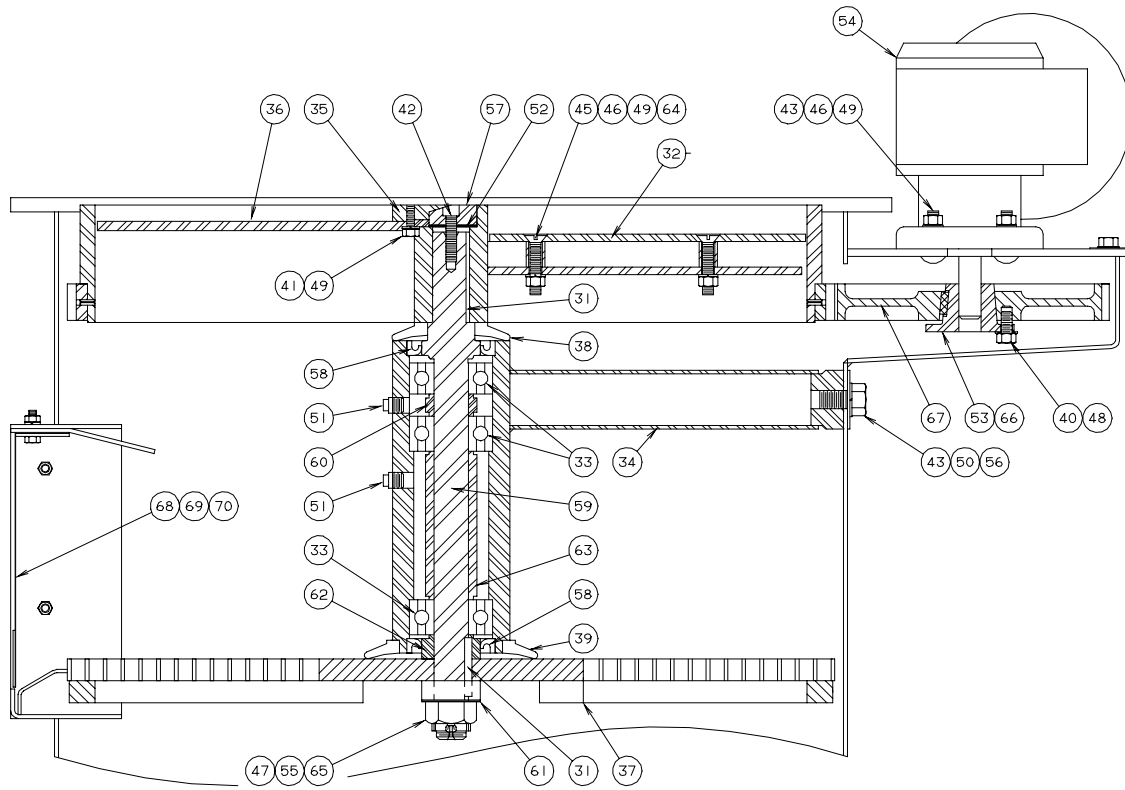

SECTIONAL DETAIL
BEARING BRACKET (ITEM 34) SHOWN ROTATED FOR CLARITY

Figure 9-5A
P24A Cutter Assembly

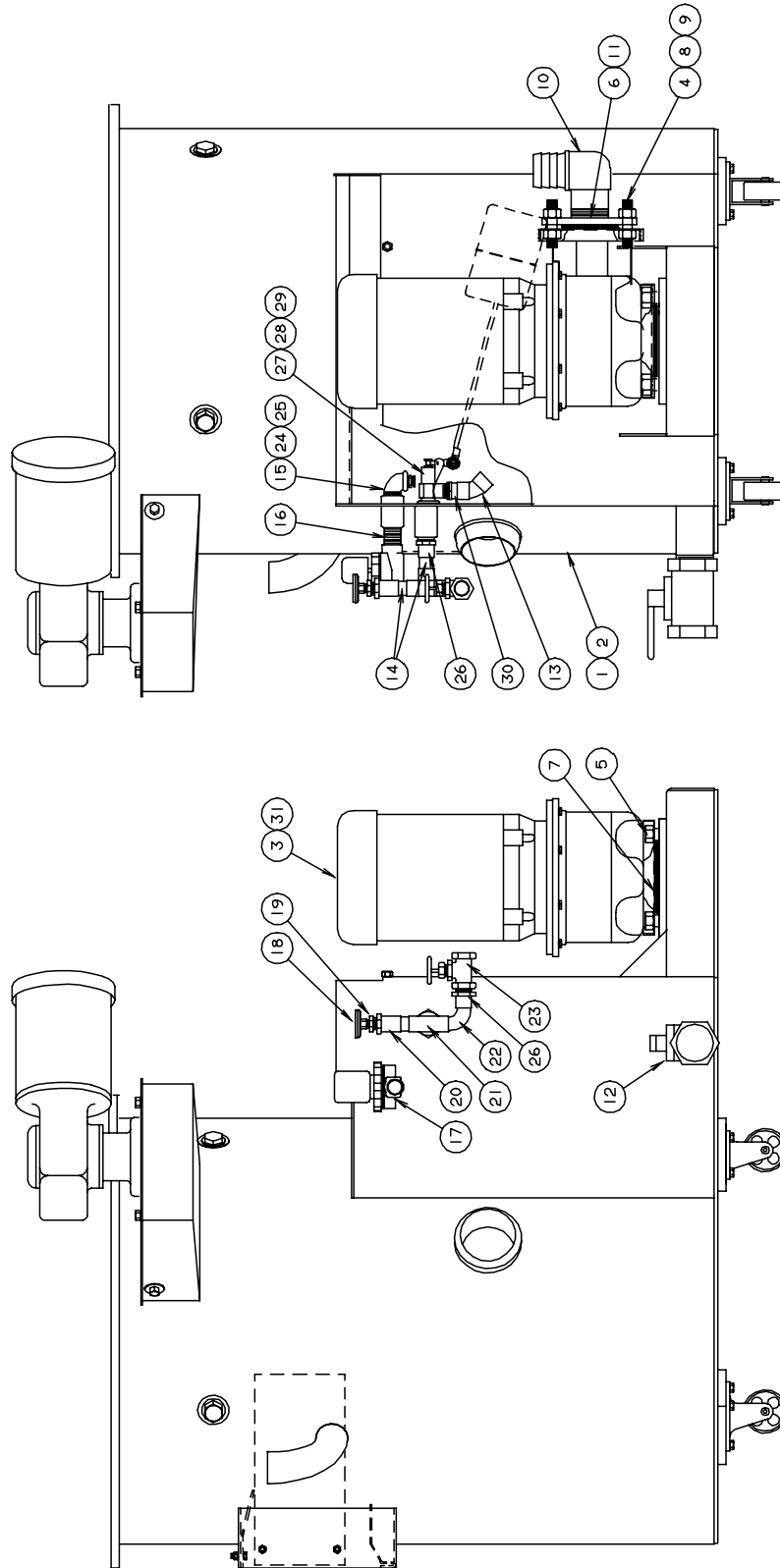

Figure 9-5B
P24A Water Tank Assembly

SERVICING OPERATIONS

Item #	Description	P24A Part Number	P34A Part Number
1	Water Tank Assembly	19T4500S2400	19T4500S3400
2	Water Box Cover (Not Shown)	19T2150C0100	19T2150C0200
3	Water Pump	See Pump Model #	See Pump Model #
4	5/8"-11 NC x 3" Long S.S. Stud	12A 2222L11190000	12A 2222L11190000
5	5/8"-11 NC x 2" Long S.S. Stud	12A 2222L11150000	12A 2222L11150000
6	2" Red Rubber Gasket	12A 2600R07000000	12A 2600R08000000
7	2 1/2" Red Rubber Gasket	12A 2600R08000000	12A 2600R09000000
8	5/8" S.S. Hex Nut (8)	12A 2240A11300000	12A 2240A11300000
9	5/8" S. S. Lock Washer (8)	12A 2250B11300000	12A 2250B11300000
10	PVC Ell 2" MPT x Insert	12A 2450E12000000	12A 2450E16000000
11	2" PVC Round Flange	12A 2535F07060000	12A 2532F06060000
12	2" FPT Valve	12A 4200G14010000	12A 4200G14010000
13	WC 45° Ell 7/8" ODC	12A 2409W0006000	NA
14	7/8" OD Copper Tubing	12A 4180A00080000	12A 41080A0009000
15	3/4" MPT x FPT PVC 90° Ell	12A 2450E07000000	12A 2450E07000000
16	3/4" S.S. Pipe Nipple	12A 3050S04010000	12A 3050S04010000
17	3/4" FPT Solenoid	12A 4200A06020000	12A 4200A06020000
18	Thermometer	12A 4170T01000000	12A 4170T01000000
19	1/2" MPT x 1/4" Brass Bushing	12A 2451B03000000	NA
20	1/2" FPT x 7/8" ODC Adapter	12A 2401W0120000	NA
21	WC Tee 7/8" ODC	12A 2422W0009000	12A 2422W0010000
22	WC 90° Ell 7/8" ODC	12A 2417W0004000	12A 2417W0005000
23	3/4" Brass Service Valve (1" for P34A)	12A 4205G06010000	12A 4205G0602000
24	3/4" MPT x 1/2" PVC Bushing	12A 2450B04000000	12A 2450B04000000
25	1/2" MPT x 1/4" PVC Bushing	12A 2450B05000000	12A 2450B05000000
26	3/4" MPT x 7/8" ODC Adapter	12A 2400W0023000	12A 2400W0023000
27	3/4" MPT Float Valve	12A 4200H06010000	12A 4200H06010000
28	Float Valve Stem	12A 4200HP0100000	12A 4200HP0100000
29	Valve Float	12A 4200HP0200000	12A 4200HP0200000
30	WC 3/4" FPT x 7/8" ODC Adapt.	12A 2401W0007000	NA
31	Key 1/4" x 1/4" x 3 3/16" S.S.	12A 2785S04000000	12A 2785S04000000
32	Cutter Adapter Plate	19T2010A1100	19T2010A05
33	Bearing	12A 2020M0200000	12A 2020M02000000
34	Bearing Bracket	19T2025B0105	19T2025B0106
35	Cutter Blade	19T2035B0100	19T2035B0200
36	Breaker Cutter Assembly	19T2160C0401	19T2160C0501
37	Tines Disc Assembly	19T2163D0302	19T2163D0403
38	Top Excluder	12A 2210E01000000	12A 2210E01000000
39	Bottom Excluder	12A2210E04000000	12A2210E04000000
40	Cap Screw, 5/16-18 x 1" S.S. (4)	12A 2215G1110000	12A 2215G1110000
41	Cap Screw, 3/8-16 x 1" S.S. (8)	12A 2215H1110000	12A 2215H1110000
42	Cap Screw, 3/8-16 x 1"	12A 2215H6110000	12A 2215H6110000
43	Cap Screw, 5/8-11 x 1 1/2" S.S. (4)	12A 2215L11130000	12A 2215L11130000
44	Carriage Bolt, 3/8-16x1 1/4" (4)	12A 2218H11120000	12A 2218H11120000
45	Mach Screw 3/8"-16 x 2" Flat (8)	12A 2226H11150000	12A 2226H11150000
46	Hex Nut, 3/8-16 S.S. (12)	12A 2240A13090000	12A 2240A13090000
47	Slotted Nut, 1-14 NF S.S.	12A 2240E12160000	12A 2240E12160000
48	Lock washer 5/16" S.S.	12A 2250B10800000	12A 2250B10800000
49	Lock washer 3/8" S.S.	12A 2250B10900000	12A 2250B10900000
50	Lock washer 5/8" S.S.	12A 2250B11300000	12A 2250B11300000
51	1/4" S.S. Sq. Head Pipe Plug (2)	12A 2475T00010000	12A 2475T00010000
52	Gasket, 3/4" OD x 7/16" ID	12A 2600R02000000	12A 2600R02000000
53	Key, 3/8" x 5/16" x 3/4" S.S.	12A 2785S01000000	12A 2785S01000000
54	Gear Motor	12A 2900M07020000	12A 2900M07020000
55	Cotter Pin, 3/16" x 1 1/2" S.S.	12A 3040S06000000	12A 2900M08010000
56	Cutter Support Washer	19T4001S0224	19T4001S0224
57	Retainer	19T4065R0100	19T4065R0100
58	Seal	12A 4080S02000000	12A 4080S02000000
59	Cutter Shaft	19T4090S0300	19T4090S0300
60	Upper Bearing Spacer	19T4130C0100	19T4130C0100
61	Tines Disc Spacer	19T4130C0200	19T4130C0200
62	Seal Spacer	19T4130C0300	19T4130C0300
63	Lower Bearing Spacer	19T4130C0400	19T4130C04
64	Spacer, 5/8" OD x 7/8" Long (8)	19T4130T0400	19T4130T0400
65	Disc Spring	12A 4138S01000000	12A 4138S01000000
66	Split Taper Bushing	12B 2060B04000000	12B 2060B01000000
67	Drive Gear	12B 2615D03000000	12C 2615D05000000

SERVICING OPERATIONS

68	Splash Curtain Holder	19T4001S0162	19T4001S0163
69	Splash Curtain Bottom Plate	19T4001S0415	19T4001S0411
70	Splash Curtain	12A 4078C03000000	12A 4078C02000000

Cutter Ring Gear Replacement.

1. Remove the water tank assembly (see water tank removal).
2. Remove the cutter assembly from the cutter shaft.
3. Remove the 3/16" drive pins (1/4" on P34A) which hold the ring gear to the cutter bank (P24=6 pins, P34=8 pins).
4. The ring gear is a shrink fit onto the cutter band and therefore will have to be driven off. It should be driven off progressively and uniformly around its circumference to avoid binding.
5. Inspect and clean the cutter bank, removing any burrs, scale, or dirt.
6. Attempt to put the new gear onto the cutter and check for fit. If it will not fit, it will have to be expanded by heat.
7. Move the ring gear away from the cutter and heat the gear uniformly to 300-400°F (150-205°C). This can be done by passing a hand/held oxy/acetylene torch uniformly over the entire ring gear. **DO NOT HEAT THE CUTTER.**
8. Align the valley of the ring gear teeth with the existing drive pin holes and carefully set the ring gear onto the cutter. Make sure it is fully seated all the way against the machined shoulder of the cutter bank.
9. After the gear has cooled, drill 3/16" holes (1/4" on P34A) in the valley (between the teeth) of the ring gear and install the drive pins. Make sure the drive pins do not protrude and interfere with the engagement of the drive gear.
10. Install the cutter assembly onto the shaft.
11. Check and adjust cutter height and meshing of the gear teeth.
12. Install the water tank assembly.

Cutter Blade Replacement. The cutter blades are designed to give many years of satisfactory service and rarely need to be replaced. If they become damaged, they can be replaced by the following procedure.

1. Disconnect and lock-out all power and remove the water tank assembly so the cutter assembly is accessible. (See water tank removal).
2. Remove the 3/8" cap screws holding the blades to the cutter plate and remove the blades.
3. Set the new blades in place and install the cap screws and washers but do not tighten.

SERVICING OPERATIONS

4. Refer to FIGURE 9-6, adjust each blade to dimension "A" and lock the blade in position by tightening the 3/8" cap screws. Note: Use a 90° square (as illustrated) to obtain the proper blade clearance required for satisfactory ice discharge. Dimension "A" is critical and should be measured at both ends of the blade. Note: 3/8" x 1" cap screw must be flush with cutter blade.
5. Make sure all bolts and nuts are tightened securely then reinstall the tank assembly.

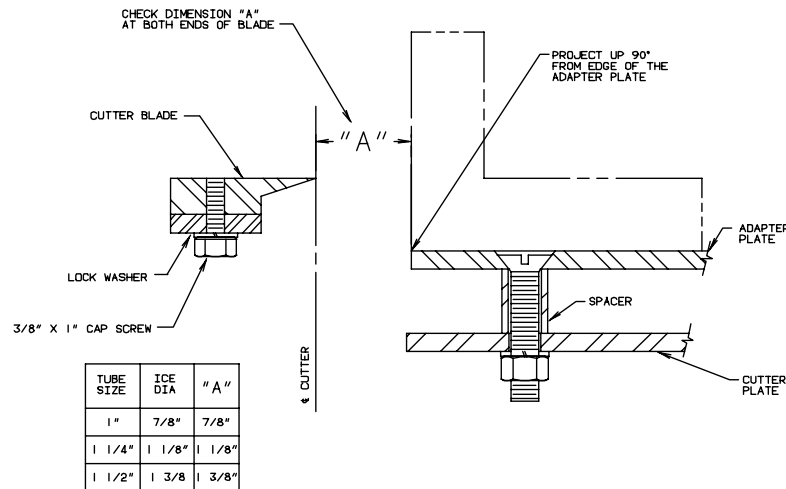

Figure 9-6
Cutter Blade and Adapter Plate Adjustment

Cutter Adapter Plate Installation.

1. Disconnect and lock-out all power to the machine and remove the water tank assembly so the cutter is accessible (see water tank removal).
 2. Locate the new adapter plate, holding the correct dimension "A" from the edge of the plate to the edge of the blade. See Figure 9.
 3. Using two C-clamps to hold the adapter plate securely in place, drill four 7/16" diameter holes through the adapter plate and through the cutter plate at the same time so they will adjoined properly.
 4. Countersink the holes in the adapter plate to make the bolt heads flush with the plate.
 5. Install bolts and spacers as illustrated and tighten securely. Note: the length of ice is determined by the spacer length. Refer to "Ice Length" for details.
 6. Install the water tank assembly to the machine.
- Note: Length of cylinder ice can be changed. See Section 10.

Pumpdown. The function of the pumpdown is to transfer all the liquid refrigerant from the freezer (evaporator) into the receiver. Pumpdown should only be performed when the freezer is clear of ice. Its main purposes are:

1. To check the total refrigerant charge.

2. To perform service or repair work on the machine.
3. To winterize the machine.
4. To remove excess water from the ammonia.
5. To prepare the machine for disconnection or moving.

To perform a pumpdown, follow this procedure:

1. With the machine running, close the liquid feed stop valve nearest the receiver.
2. Open the water tank drain valve partially to allow a continuous flow of warm make-up water into the water tank and still maintain a good level in the tank. An auxiliary supply of warm water (not to exceed 100°F) may be used if available. Warmer water affords a more complete pumpdown.
3. Allow the machine to operate and complete two freeze and harvest cycles.
4. After the second harvest cycle, stop the machine, throw the electrical disconnect, and lock-out all power to the machine.
5. Remove wire #17 from the freezer pressure switch (2PS) and insulate the end to prevent a short circuit.
6. Restore power to the machine and start the water pump only, to circulate warm water through the freezer.
7. When the suction pressure increases to 70 psig or higher, start the compressor and allow the machine to stop automatically by the low pressure switch at approximately 15 psig. (Lower pressure can be obtained by jumping out the pressure switch.) Remove all power from the machine before opening the control panel cover. With the pressure switch jumped out, the machine can be manually started and stopped. Do not operate the machine below 2 psig.
8. When the desirable pumpdown is obtained, close the thawing gas stop valve, #90, and the compressor discharge line stop valve. Other valves may also be closed to isolate a particular area which may require attention.
9. To perform a total pumpdown, it may be necessary to apply heat directly to the oil trap in order to boil off the liquid ammonia and oil mixture.

Removal of Ammonia Refrigerant from the Machine. Liquid ammonia can be removed from the machine through the receiver drain valve. Refer to Sections 1, 2 and Appendix A for special warnings and instructions regarding the handling of ammonia. Make sure you are familiar with and technically qualified to handle anhydrous-ammonia refrigerant.

SERVICING OPERATIONS

! WARNING !

It is not recommended that refrigerant to be transferred from a refrigeration system directly into a cylinder. If such a transfer is made, the refrigerant cylinder must be an approved, CLEAN cylinder--free of any contaminants or foreign materials--and must be weighed continuously to assure contents do not exceed net weight specified by cylinder manufacturer of any applicable code requirements.

! WARNING !

If ammonia vapor is released from the machine, it may be purged into water which will absorb it. Follow the purging instructions. See “Purging Non-Condensables”.

Note: Observe all local codes when handling and discharging anhydrous-ammonia refrigerant.

Refrigerant Leaks. Anhydrous ammonia leaks can be detected by odor, sulfur stick, soap solution, or test paper. The odor is normally noticed first and the location of the leak is found with soap or sulfur stick. Soap solution can be purchased from your refrigeration supply house or it can be made by mixing four parts water, one part liquid soap, and a few drops of Glycerin for better capillary attraction.

- Apply soap solutions with a narrow brush or spray bottle to all joints, welds, or areas of suspicion. The solution will form bubbles if there is a leak.

Sulfur sticks and test paper can be obtained from your ammonia supplier.

- Light the end of the sulfur stick and pass it around suspected points of leakage. A white cloud will form where a leak is, even if it is very small.
- Moisten a strip of test paper and pass it around the suspected area. If the paper comes in contact with ammonia, it will turn red. Coils submerged in water, or condenser cooling water may be tested by dipping a strip directly in the water. If ammonia is present, the paper will turn red. Always remove refrigerant pressure from the vessel, tubing, or component part before repairs are attempted.

Non-condensable Gasses. Satisfactory operation of the machine is not possible if non-condensable gases (usually air) are present in the system. Excessive condensing pressure is an indication of such gases. Excessive condensing pressure in water-cooled condensers may also be due to the accumulation of scale in the cooling coil or due to insufficient cooling water or excessive water temperature. See “Water-Cooled Condensers”, Section 7, and Section 9 “Condenser Cleaning”.

Purging Non-Condensables. Air and other non-condensable gases in a refrigeration system are not desirable. Purging air from your Tube-Ice machine will greatly improve system performance and save money.

Non-condensable gas effects are:

1. Higher condensing pressure than desired.
2. Greater electrical power consumption.
3. Reduced refrigeration capacity.
4. Longer than normal compressor running time.

5. Slow ice release and long thaw cycle.

Air collects mostly in high pressure condensers, receivers, and other high-pressure components. It collects mostly in the coolest, lowest-velocity area of these components.

Evaporative condensers usually have purge points at the top of the outlet header of each circuit.

Receivers usually have a purge point at the top, away from the inlet, where it is coolest and the gas velocity is the lowest.

The freezer can be purged through the valve at the top of the suction accumulator, but should be done only during the thaw cycle or after the system has been idle at least two hours.

Follow this procedure when purging:

1. Connect a suitable hose to the purge valve and place the other end in water.
2. Open (slightly) the purge valve and allow air to escape.
3. Air will appear as bubbles in the water rising to the surface.
4. The larger the bubbles, the more air is escaping.
5. DO NOT leave the purge hose unattended.
6. When air bubbles are reduced to a minute size (smaller than 1/16), it can be considered that most of the air has escaped and purging can be ceased at this point.
7. Additional purging can be done at other purge points.
8. When purging is completed, close the valve, disconnect the hose, and install a plug in the purge valve.

Draining the Oil Trap. After many hours of operation, the oil which escapes the oil separator will pass through the receiver and to the freezer where it will settle in the oil trap, #36. Indication of oil in the trap will be evident by the frost line. At the end of a freeze cycle, frost (or ice) will form on that part of the oil trap where oil is not present. When frost is seen only on the top 1/4 to 1/2 of the oil trap, the oil trap should be drained. Do not allow the oil trap to fill completely with oil, or it will cause loss of ice production and possible refrigerant floodback to the compressor.

1. Stop the machine and wait 12 hours or more.
2. Attach a suitable hose to the oil trap drain valve #61. Make sure there are no kinks or restrictions in the hose.
3. Open the valve slightly until oil begins to drain.
4. Continually observe the oil flow, being ready to close the valve quickly.

! DANGER !

Do not leave the oil trap drain valve opened or unattended--severe injury may result

! DANGER !

5. When a small amount of liquid ammonia begins to spew out, immediately close the valve.

SERVICING OPERATIONS

6. Remove the hose and install a plug in the valve. DO NOT attempt to reuse any oil taken from the system unless it is properly reclaimed and meets the proper specifications.

Removing Excess Water from Ammonia

If excessive water is in the ammonia, it will cause frost on the suction line to the compressor, and dilution of the oil. This condition should not go uncorrected and the water needs to be removed.

1. Perform a total pumpdown of the freezer. See “PUMPDOWN”.
2. A total pumpdown is accomplished when there is no frost or ice on the freezer or oil trap and the freezer pressure is below that pressure relative to the surrounding temperature. Refer to the Temperature-Pressure chart for ammonia.
3. With the freezer pressure below 25 PSIG, attach a hose to the oil trap drain valve, #61 and extend the other end into a container (5 gallon bucket, etc.).
4. Open the hot gas check valve (101).
5. Open the drain valve a little and drain out the oil and water that is present.
6. Continue to drain oil/water, and purge the freezer and compressor to 0 PSIG.
7. Close the compressor discharge stop valve and the oil return valve. Make sure the power is disconnected and locked-out.
8. Drain the compressor oil, remove the compressor side cover and clean the inside of all oil and foreign matter, and reinstall the side cover.
9. Connect a vacuum pump, or pumps to the freezer and compressor, and evacuate them to 2000 microns or below while maintaining 60°F (10°C) or higher room temperature. A 5 CFM or larger vacuum pump is best.
10. During evacuation, add new oil to the compressor. Also purge the receiver for non-condensables.
11. After evacuation, break the vacuum by manually opening the liquid line solenoid valve and gradually opening the liquid line stop valve (29 or at the receiver), letting liquid ammonia enter the freezer and raise the pressure.
12. When the freezer (suction) pressure is up to at least 60 PSI, manually close the liquid line solenoid valve and restore power to the machine.
13. Open the compressor discharge valve, oil return valve, and all other valves that should be opened for normal operation.
14. Turn the “HAND/AUTO” switch to “HAND”. When the receiver liquid level is near its normal operating level or the pressures are near equal and the compressor crankcase has warmed, the

compressor can be started and ice production resumed.

15. After several cycles, check the system for symptoms of excessive water, and if necessary, repeat the pumpdown and evacuation procedure.

Note: whenever excessive water is present in the system, the source should be identified and corrections made prior to further operation.

Circulating Water Pump Motor. The motor bearings are prelubricated and sealed. They require no further lubrication. The pump should operate with the water level above the impeller housing.

The pump is equipped with a mechanical seal which is self-adjusting and requires no lubrication. However, the pump should not be operated unless circulating water. The pump manufacturer recommends that a mechanical seal be kept as a spare. When ordering a seal, specify pump size, type, serial number, and manufacturer's name as indicated on the nameplate.

Solenoid Valves. The P24 and P34 are equipped with several solenoid valves to perform various functions for proper operation and good ice production.

The Thaw Gas Solenoid Valve (18), Figure 9-7, is opened during the thaw cycle to allow warm gas to pass from the receiver to the freezer. Repair or replace as follows:

1. With the receiver pressure higher than the freezer pressure, manually open the valve by turning the manual stem out until you hear gas passing through the valve.
2. Close the two hand stop valves (#90) tight on either side of solenoid valve when there is vapor only in that part of the line.
3. Loosen the 1/4" tubing compression nut at the strainer slightly to purge that section of the thaw gas line and continue to purge until all pressure is relieved.
4. Repair or replace the valve as needed making sure all connections are tight.
5. With the valve manually opened (stem out), open slightly only one stop valve #90 and purge air from the line through the 1/4" tubing compression nut at the strainer. Then close that valve #90 and open the other #90 valve to purge air from that section of the line.
6. When purging is complete, tighten the compression nut, manually close the solenoid valve (stem in until it protrudes about 1/8" out from the housing).
7. Reopen stop valves #90 and check for leaks.
8. Adjust the regulating valve to approximately 60-65 psig to the freezer pressure during harvest. See Page 5-7.

SERVICING OPERATIONS

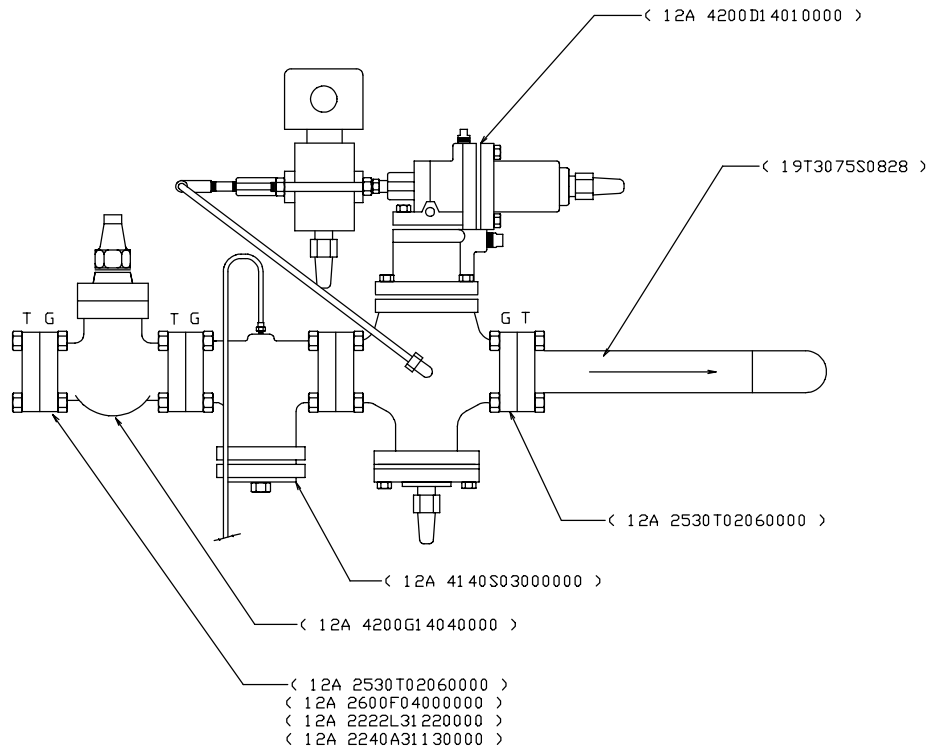

FIGURE 9-7
Thaw Gas Solenoid Valve Assembly

The **Liquid Feed Solenoid Valve** (20), Figure 9-8, is opened and closed during the freezer cycle by the float switch #10, in order to maintain the proper freezer refrigerant level. It is closed when the machine is off to prevent liquid flow from the receiver to the freezer.

Repair or replace as follows:

1. With the receiver pressure higher than the freezer pressure close the hand stop valve #58 and #29 (upstream and downstream) in the liquid line between the receiver and liquid feed solenoid valve.
2. Manually open (screw stem in until only 1/8" protrudes) and allow the liquid to flow to the freezer and clear this part of the line of liquid, leaving only vapor.
3. Close the other hand stop valve #29 (downstream). This will isolate the solenoid valve.
4. Purge the remaining ammonia from this line through the strainer purge valve #75.
5. Repair or replace the valve as needed, making sure all connections are tight.
6. Evacuate or purge air from this isolated part of the liquid line through the strainer purge valve.
7. After purging, manually close (screw stem out) the solenoid valve and open stop valves #29 and #58, check for leaks.

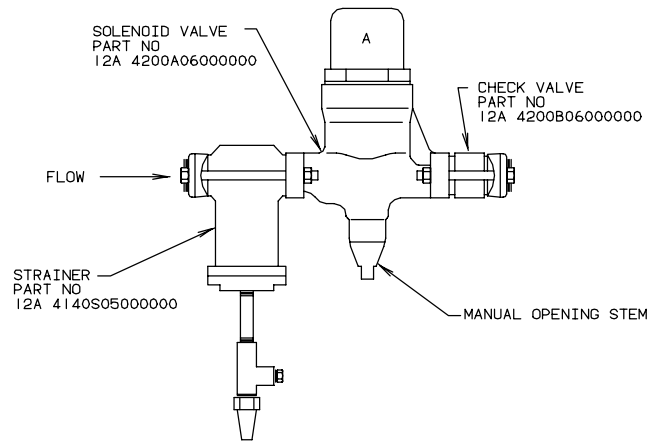

FIGURE 9-8
Liquid Line Solenoid Valve

Thaw Chamber Check Valve. This valve is closed during the freeze cycle to keep the thaw chamber from filling with liquid ammonia. To manually open simply turn the manually opening stem inward. Repair or replace as follows:

1. Pump the machine completely down with check valve in the manually open.
2. Shut the thaw gas hand valve (90).
3. Vent additional ammonia vapors from oil trap drain valve (61).
4. Replace or repair valve.
5. Shut oil trap drain valve and open thaw gas hand valve.
6. start machine in normal operating condition.

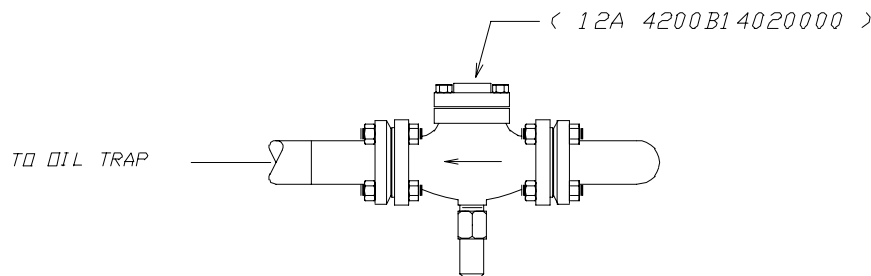

FIGURE 9-9
Thaw Gas Check Valve

SERVICING OPERATIONS

Water Flush Solenoid Valve (63) is opened during the thaw (harvest) cycle, to flush out some of the impurities from the water in the tank, thereby improving the ice quality. Repair or replace as follows:

1. Turn off the water supply to this valve.
2. Dismantle the valve and inspect for dirt, etc., and wear. Reverse osmosis water can cause premature wear and erosion of the brass parts of this valve, you may want to consider replacing the valve with a stainless steel valve.
3. Repair or replace the valve as needed.
4. Turn on the water supply and check for leaks.

Compressor Cooling Solenoid Valve (64) is opened all the time the compressor is running. It provides water for cooling the compressor oil and heads. There should be no water flow through the compressor heads when the compressor is not running. Water through the heads (water jackets) during off times could cause liquid ammonia condensing in the crankcase and dilute the oil or slug the compressor at start up. Repair or replace this valve by following the same procedure outlined for the Water Flush Valve, #63.

Compressor Oil Changing

See Table 7-4 for frequency recommendations.

1. Turn off power to the machine and make sure the compressor crankcase heater is not energized.
2. Drain the oil through the oil drain valve located at the base of the compressor.
3. When all oil is drained, new oil of the required specifications can be pumped into the crankcase to the proper level.
4. Turn the power on and allow the crankcase heater to warm the oil prior to start-up. Be sure to confirm sufficient oil pressure at start-up.
5. Restore power to the crankcase heater allowing time to warm the oil. Be sure to confirm sufficient oil pressure at start-up.

Compressor Inspection

1. Close the compressor suction valve and allow the machine to stop by low pressure cut-out.
2. Close the compressor discharge valve, oil return stop valve. Disconnect and lock-out all power to the machine.
3. Drain the oil through the oil drain valve located at the base of the compressor and purge the compressor until all pressure is relieved.
4. Remove the compressor side cover(handhole cover) being careful to protect the gasket and surface from damage.

SERVICING OPERATIONS

5. Inspect the crankcase inside for foreign material such as sludge, metal flakes, burrs, or anything which may look unusual, indicating excessive wear or damage.
6. Remove all remaining oil and wipe out the compressor with a lint-free cloth. The extent of internal inspection should be dependent on the degree of evidence of wear.
7. Inspect and clean the oil strainer. Cleaning can be accomplished with light oil, diesel fuel or mineral spirits. Make sure excess cleaning agents are removed prior to closing the crankcase.
8. Clean the oil sight glass and install the side cover plate using a new gasket if necessary and torquing bolts to the correct specification.
9. Evacuate the compressor and add new oil to the crankcase.
10. Restore power to the crankcase heater allowing time to warm the oil.
11. Open the suction valve, discharge valve, oil return valve, and any other valves which may have been closed for servicing and check for leaks.
12. Check and confirm sufficient oil pressure as you witness at least one complete cycle when operation is resumed.

Belt Tension. New belts should be checked after the first day running, after the first week for tension, then at regular intervals for tension, alignment, and wear

1. Always use matched sets or banded belts for multiple belt applications.
2. Too much tension shortens belt life and motor bearing life.
3. Never use a petroleum base belt dressing.
4. The proper tension is just enough to prevent slipping.

Reasons for premature wear.

1. Pulley misalignment
2. Belts not matched
3. Dirt or foreign material present
4. Excessive slipping (loose tension)

Belt Replacement. Belts which are worn, cracked, frayed, or over stretched should be replaced.

1. Remove the belt guard and loosen motor hold-down bolts.
2. Move the motor and sheave closer to the compressor until there is enough slack to remove the old belts.
3. Remove the old belts and clean the sheave groove if necessary with non-flammable, non-toxic degreasing agent or commercial detergent.

SERVICING OPERATIONS

4. Install new belts by rotating the belt and sheaves to obtain seating in the grooves.

Note: on drives having more belt grooves in the sheaves than needed, use the grooves closest to the motor and compressor. Make sure that the belts are all slack on the same side of the drive, preferably the bottom, prior to tightening.

5. Move the sheaves apart until the belts are snug.
6. Check the motor and compressor shafts to make sure they are parallel, and check the flywheel and motor sheave with a straight edge, string, or wire to make sure they are parallel and in the same plain. Make adjustment as required.
7. Adjust tension following these guidelines:
 - a) Best tension is the lowest tension at which the belts will not slip under the highest load condition.
 - b) Check tension after the first two to four hours and again after 24 to 48 hours of operation, then periodically thereafter.
 - c) If a belt slips, tighten it.
8. Retighten motor hold-down bolts after each adjustment.

Compressor Servicing. Refer to your compressor manual for specific instructions regarding repair and servicing of internal parts. It is important to be familiar with the operation and function of your equipment so you can provide the best possible service.

10. Options and Accessories

Options and Accessories

Crushed Ice Production Your P24 or P34 Tube-Ice machine is capable of producing crushed ice with no loss of capacity; however, there are certain changes to be made in order to convert to crushed ice production. The following modifications are required:

1. Remove the existing cutter adapter plate and install new adapter plates for crushed ice.
2. Remove the existing tines disc assembly and install new crushed ice disc assembly.
3. Remove the existing ice shield and scraper and install new shield and scraper.
4. Readjust the freezer pressure switch to produce ice 3/16"-1/4" thick for crushed ice.

To remove and install cutter parts, it will be necessary to first remove the water tank assembly for unrestricted access. The result is that the ice is approximately 1/2" long and frozen only 3/16-1/4" thick. A modification of this type is not one you would want to make every time a temporary change to crushed ice was wanted. Contact your distributor for more information and complete details.

Length of Ice. Ice length can be changed by increasing or decreasing the length of the spacer under the adapter plates. The water tank assembly must be removed for making this modification. When installing the adapter plates, make sure the horizontal dimension from the cutter blade edge to the edge of the adapter plate is as follows:

7/8" space for 1" tubes

1 1/8" space for 1 1/4" tubes

1 3/8" space for 1 1/2" tubes

See Figure 9-6 for illustration of this critical adjustment.

! CAUTION !
Always witness several ice making cycles after making conversions or modifications to make sure all ice clearing during the set thawing time and adjust timer accordingly.
! CAUTION !

PLC (Programmable Logic Controller)

This section of the service manual applies only to Tube-Ice[®] models equipped with a Mitsubishi Fx_{on} programmable controller and 10DUE operator interface. The PLC version of the Tube-Ice[®] enhances the operation of the standard version by providing: Selectable automatic restart after a power failure, choice of timed or pressure switch controlled freeze cycles, programmable blowdown adjustment, diagnostic indicators, power failure indication, alarm relay, built in cutter delay, programmable conveyor control contacts, estimated ice production display, and a total cycle counter.

mitsubishi PLC

The Mitsubishi Programmable controller contains 14 inputs and 10 outputs. The power supply for the unit can be 100-240VAC, 50/60 Hz and is internally fused for 3A. The inputs are 24VDC internally fused for 5-7mA. All 24VDC control wiring is blue in color and is distinguished from the red 240VAC control wiring (Figure 10-3). The outputs are externally fused for 2A. Outputs 0, 1 and 2 are dry contacts used for sequencing and conveyor control. Outputs 3-11 are relay type with 200/240 V connections.

Figure 10-1 shows the Mitsubishi PLC installed in the Tube-Ice[®] machine. The LED indicators on the right hand side of the Mitsubishi PLC indicate the power, run and error status of the PLC. When power is on to the PLC and the run/stop switch is in the run position the power and run indicators will be illuminated. If an error is indicated contact the factory immediately.

The LED indicators on the left hand side of the Mitsubishi PLC indicate the input and output status of the PLC. If the input (X#) indicator is illuminated, then the PLC is receiving the input. If the output (Y#) indicator is illuminated, then the PLC is sending the output. Use of these LED's will be helpful in troubleshooting the machine.

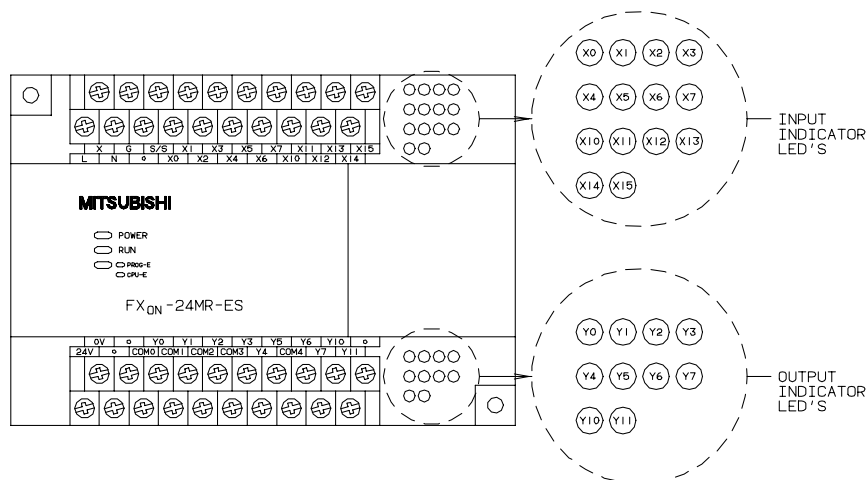

Figure 10-1
Mitsubishi Programmable Logic Controller

KEY FEATURES

Options and Accessories

Automatic Restart. TUBE-ICE machines are equipped with a power failure relay. This relay prevents the machine from automatically restarting in the event of a power failure. The machine should have power on the crank case heater for a minimum of two hours before it is restarted with the start switch. The PLC allows the user to select between having to restart the machine manually or restarting automatically, two hours after power is restored.

Timed Freeze Cycle. The normal mode of operation for the length of the freeze cycle is determined by the freezer pressure switch setting. The freezer pressure switch will automatically compensate for variations in water temperature and operating conditions to provide consistent ice thickness. The PLC allows the length of the freeze cycle to be a fixed time. The freeze time will have to be adjusted as water temperature and operating conditions change, however this method of control can prove helpful when sequencing two or more machines to avoid simultaneous harvest cycles.

Blowdown Adjustment. Normal operation is for blowdown to occur during the entire harvest cycle. The PLC allows the user to adjust the amount of blowdown by setting the length of time that blowdown will occur. The time can be set from zero (no blow-down) to five minutes.

Diagnostic Indicators. The PLC provides text messages in the event of a malfunction or fault. The PLC will alert the user in the event of the following conditions.

- high or low pressure
- short cycling (three consecutive freeze cycles five minutes or less in duration)
- long cycle (a freeze cycle lasting more than 60 minutes)
- water pump overload
- cutter motor overload
- loss of oil pressure
- power failure

Cutter Delay. PLC equipped machines delay start of the cutter motor for eight seconds after the water pump has stopped. This allows water to drain from the freezer and cutter assembly before the cutter assembly starts turning, thereby reducing the amount of water that can be splashed out the ice discharge opening.

Alarm Relay. The PLC equipped machines have an alarm output relay that can be used to initiate external alarms such as a siren, light, telephone dialer or modem.

Conveyor Control Contacts. Control contacts are provided for starting and stopping conveyors in sequence with the ice machine. Normally the contacts are closed during the entire harvest cycle and open during the freeze cycle. In many cases it is necessary to run the conveyors for a period of time

longer than the harvest cycle to allow the conveyor to finish delivering the ice. The PLC allows the user to set the duration of the conveyor run cycle independently of the harvest cycle. The user can also set a delay between the start of the harvest cycle and the conveyor start.

Estimated Ice Production. The PLC allows the user to enter the weight per cycle of ice being produced. This weight will depend on how the machine has been set up to run and the size of the hole in the ice, however the weight per cycle should remain relatively constant from cycle to cycle. The PLC uses this information coupled with the freeze and harvest times to report the capacity based on the last cycle in lbs of ice per day. The PLC will also track total accumulated ice production in lbs. over a period of time. This value can be reset to zero by the user.

The operator interface shown in Figure 10-1, provides two 16 character lines of text which are used to report faults, operating conditions, and programming information to the user. The key pad is used to enter or modify values in the PLC. Operation of the interface is menu driven. Basic directions for operation are displayed on the operator interface.

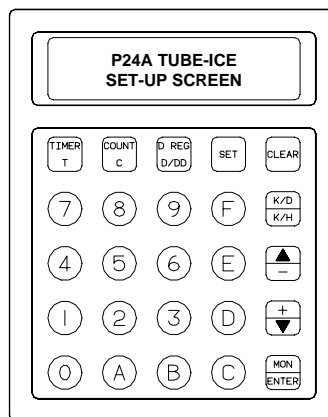

**Figure 10-2, Operator Interface
for PLC (Programmable Logic Controller)**

GETTING STARTED

The operator interface displays two lines of text, however the message or instructions may be longer than can be displayed on two lines. The rest of the text can be accessed by pressing the up and down arrows (scrolling). Scrolling progresses down the screen one line at a time.

When power is first connected to the unit or restored after a power interruption, the interface will display the message shown below.

PRESS START
POWER FAILURE
TIME TILL START
MINUTES

With the control switches in the “ICE” and “ON” positions the machine will begin a harvest cycle when the start button is depressed. The machine starts in the harvest cycle to clear any ice from the freezer if a power failure has occurred.

The interface will display the current harvest time and the previous cycle harvest time during the harvest cycle.

HARVEST ###
PREV HRVST ###
B=RESET CYCLE
C=SET-UP SCREEN

Upon completion of the harvest cycle the machine will begin the freeze cycle.

The interface will display the current freeze time and the previous cycle freeze time during the freeze cycle.

FREEZE ###:##
PREV FREEZ ###:##
B=RESET CYCLE
C=SET-UP SCREEN

Upon completion of the freeze cycle the machine will begin the harvest cycle.

If the on/off switch is moved to the “OFF” position (or the ice level sensor opens) the machine will complete the current ice making cycle then stop. The interface will indicate that the machine is standing by. This message will be displayed anytime the machine is turned off. If the machine is off because of a fault (safety) or power interruption a different message will be displayed.

STANDING BY
A=PUMPDOWN
B=RESET CYCLE
C=SET-UP SCREEN

Pressing “A” on the operator interface at this point will cause the machine to begin a pumpdown sequence.

PLC (Programmable Logic Controller)

When the machine is pumping down the operator interface will indicate “PUMPING DOWN”. During the pumpdown sequence the compressor is running and the liquid feed valve (A-Valve) is closed. The machine will complete one harvest cycle then the compressor will continue to run until the freezer pressure reaches the low pressure safety switch setting. The pumpdown sequence will move most of the refrigerant from the freezer to the receiver for servicing operations. It is recommended that the king valve be closed during servicing of the ice machine.

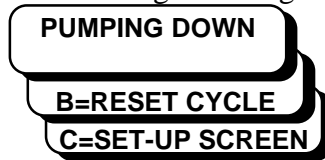

Upon completion of the pumpdown sequence the interface will display the message shown below. It will be necessary to press the start button to resume operation. This screen will also appear upon completion of a clean cycle or after a fault has been detected and reset. The words “PUMPED DOWN?YES” will appear if the machine is pumped down.

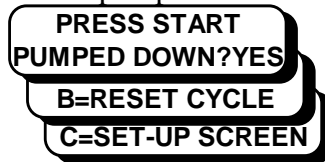

When the switches are in the “ON” and “CLEAN” positions the machine will begin a clean cycle after completing the current ice making cycle. The interface will display the time that the machine has been in a clean cycle. During the clean cycle the water pump will run. To stop the water pump (clean cycle) move the on/off switch to the “OFF” position. To restart the water pump (clean cycle) return the switch to the “ON” position and press the start button.

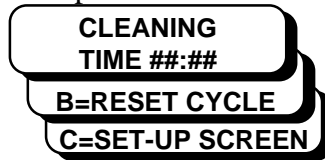

The machine will automatically exit the clean cycle after a 2 hour period. At the completion of the clean cycle the interface will always return to the start up display, requiring that the start button be depressed

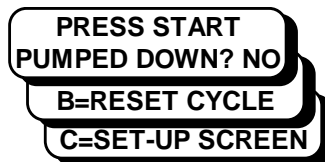

PLC (Programmable Logic Controller)

MACHINE FAULTS

Hi/Low Pressure. The interface will display the message shown below if the combination high/low pressure safety switch opens. The machine will stop immediately.

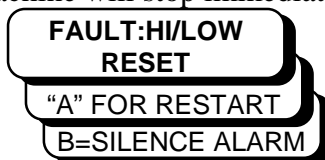

When the low pressure switch resets or the manual reset button for the high pressure safety is depressed and the pressure is in the acceptable range, the interface will display "PRES OK".

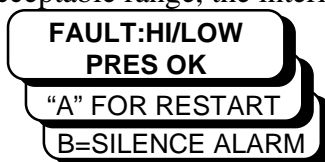

After the safety switch is reset it will be necessary to press the "A" button on the operator interface to return to the start up screen. Pressing "B" on the operator interface at this time will open the alarm contacts. Button "C" will always change the display to the set-up screen when a fault screen is displayed.

Cutter or Pump Overload. The interface will display the message shown below if the water pump overload protection trips open. The machine will stop immediately, and the overload reset button located on the motor starter must be depressed.

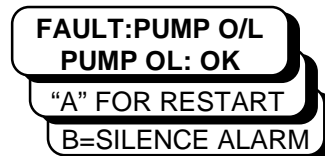
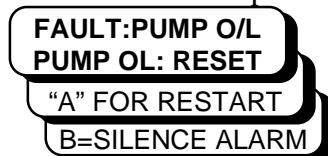

When the overload has been reset the interface will display "PUMP OL: OK". It will be necessary to press "A" on the operator interface to restart the machine. The cutter overload fault display operates identically to the pump overload displays.

Low Oil Pressure: The interface will display the message shown below if the compressor oil pressure safety switch opens. The machine will stop immediately, and the oil pressure switch must be reset manually, by depressing the red button located on the front of the oil pressure safety switch.

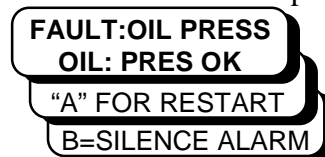
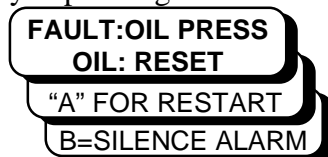

When the oil pressure safety switch has been reset the interface will display "OIL: PRES OK". It will be necessary to press "A" on the operator interface to restart the machine.

PLC (Programmable Logic Controller)

Compressor Overload: The interface will display the message shown below if the compressor motor safety overload switch opens. The machine will stop immediately. The compressor overload will reset automatically after the compressor has time to cool off.



When the compressor overload resets the interface will display "COMP. OK". It will be necessary to press "A" on the operator interface to restart the machine.

Long or Short Cycle Safety: The interface will display the messages shown below if there is a long or short cycle condition. The machine will stop upon indication of either of these conditions. A long cycle is defined as a freeze cycle that extends for a duration of one hour. This could be caused by an open drain valve, leaking hot gas valve or defective compressor. The short cycle safety will stop the machine after three consecutive freeze cycles of less than five minutes duration. Short cycling can be caused by a restriction in the liquid line, inadequate make-up or circulating water, or a defective freezer pressure switch.



It will be necessary to press "A" on the operator interface to restart the machine.

! CAUTION !

When the operator interface indicates a fault, something has gone wrong. Every effort should be made to discover the reason for the fault. Do not simply reset the fault and resume operation. The underlying cause will likely reoccur, interrupt ice supply and potentially damage equipment.

! CAUTION !

PLC (Programmable Logic Controller)

CHANGING THE SETUP VALUES

Several operating parameters of the machine can be modified. The set up screen must be accessed to make any modifications. The set up screen can be accessed by pressing the “C” button on the operator interface. When in the setup screen the interface will display the information shown below. The arrow buttons can be used to scroll through the lines of the screen.

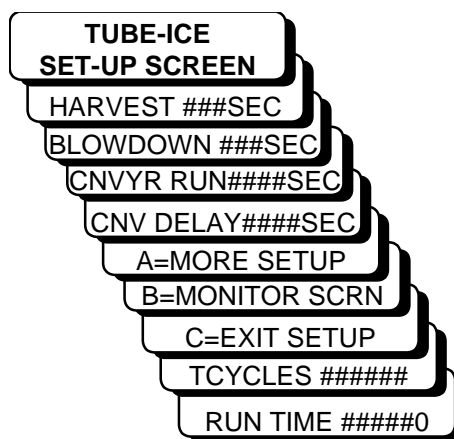

To change the value of a variable, scroll to that variable on the screen, press the “SET” button on the interface, enter the new value using the numeric key pad and press “ENTER”. The only variables that can be changed from this screen are the harvest time, blowdown time, conveyor run time, and conveyor delay time. The last two lines of the display report total cycles and run time of the machine.

Pressing “A” on the operator interface while in the set up screen will allow you to access a second set up screen where the autostart and the timed freeze cycle features can be turned on or off. The display will be as shown below.

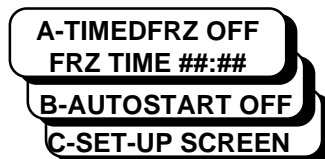

Pressing “A” from this screen will toggle the timed freeze feature from off to on. If the display reads “A-TIMEDFRZ ON” the timed freeze feature is active.

Pressing “B” from this screen will toggle the auto-restart feature from off to on. If the display reads “B-AUTOSTRT ON” the automatic restart feature is activated.

The user can also set the freeze time from this screen.

PLC (Programmable Logic Controller)

MONITORING FUNCTIONS

From the set up screen two additional screens can be displayed by pressing “B” on the operator interface. These two screens are referred to as monitor screens. The first screen displays the cycles and lbs of ice produced since the operator has reset the counter. The screen is shown below.

```

##### CYCLES
##### LBS ICE
A = RESET
B = NEXT SCREEN
  
```

Pressing “A” from this screen will reset the cycle count and pounds of ice produced to zero. This will not reset the total cycles displayed on the main set up screen.

Pressing “B” from this screen will call the second monitor screen. The second monitor screen displays the previous total cycle time, lbs of ice produced per cycle and lbs of ice produced per day based on the last cycle time. The screen is shown below.

```

PREV CYCLE ##:##
ICE/CYCLE ###LBS
ICE/DAY #####LBS
C=SET-UP SCRIN
  
```

The user can set the pounds of ice per cycle from this screen. The capacities and ice production totals calculated on these two screens are based on the user input number for pounds of ice per cycle. This depends on how thick the ice is and how the machine is set up. For best results, the number used here should be the average actual measured weight from two or more consecutive cycles.

Options and Accessories

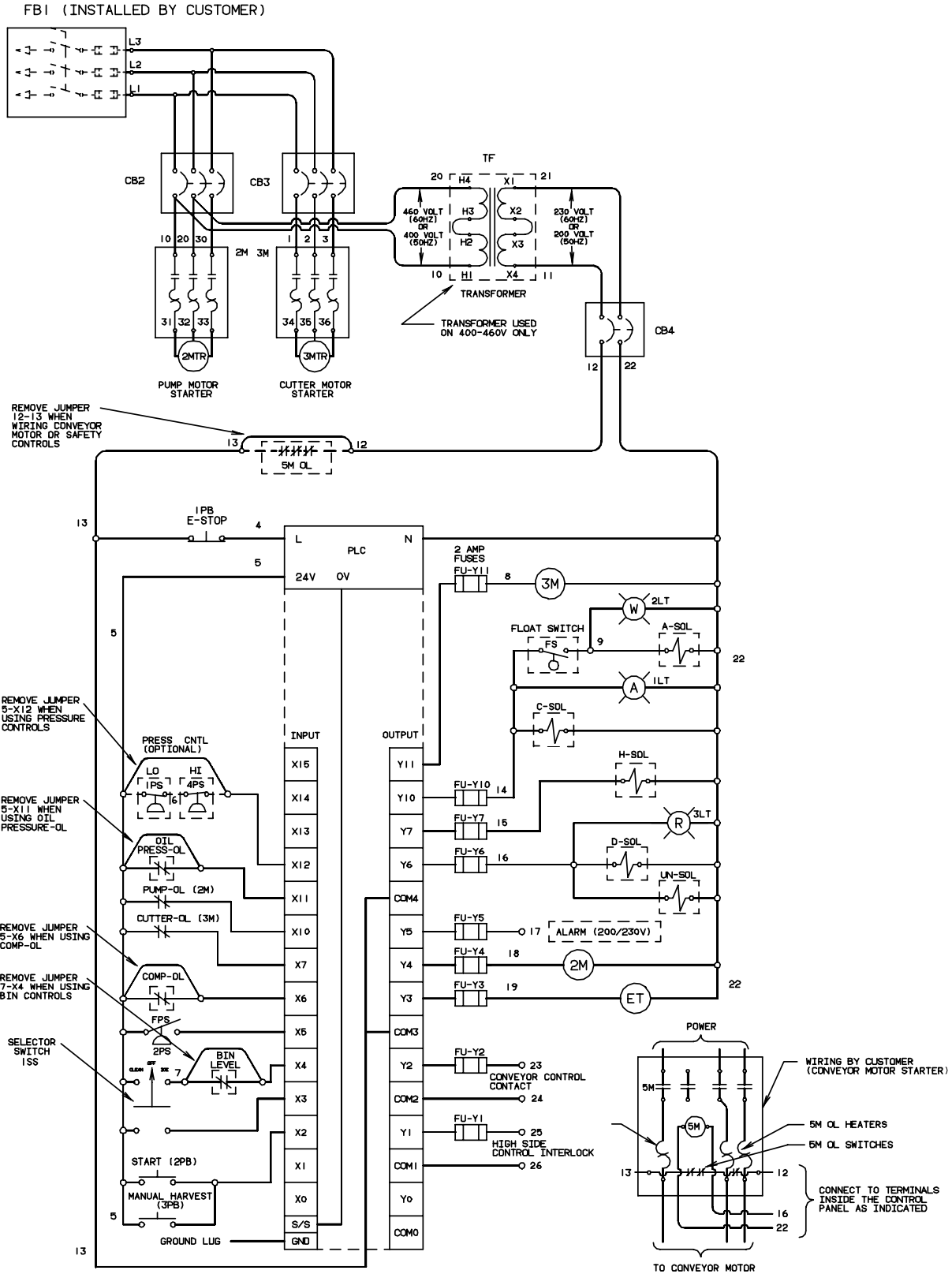

Figure 10-3
Wiring Schematic

Reduced Voltage (Soft-Start) Cutter Motor Starters

Several Vogt Tube-Ice machine models are available from the factory with a reduced voltage “soft” cutter motor starters. These units reduce inrush current to approximately 200% of rated full load amps, as compared to 600% for across the line start. The units are also available for after market or retrofit installation. The soft starters include a NEMA 12 (water tight) enclosure, and should be mounted near the control panel.

Initial Torque Adjustment

The initial Torque adjustment is factory preset for maximum torque (maximum starting voltage).

1. Rotate the START TIME adjustment fully clockwise (to 100) so that the longest starting time is obtained.
2. Rotate the INITIAL TORQUE adjustment to midrange on the dial (50), to lower the starting torque.
3. Start the motor. If more or less torque is required to break the load free, turn off the power, rotate the INITIAL TORQUE adjustment in the appropriate direction until the load just begins to move when power is first applied.

Start Time Adjustment

The START TIME adjustment range is 1/2 to 30 seconds for a motor voltage from 10% to 100% of line voltage. The higher the value of the INITIAL TORQUE, the shorter the duration of the overall time period. In most applications it is desirable to start the motor as quickly as possible without causing unnecessarily high inrush currents.

1. During the INITIAL TORQUE adjustment process, the START TIME was adjusted for the longest start possible. If a shorter time is desired, rotate the adjustment toward 0 (counterclockwise).
2. Start the motor and determine if the soft start is acceptable. If not, continue to rotate the start time adjustment until an acceptable start is obtained.

Note: The soft starter should be adjusted to bring the cutter up to full speed in 10 to 15 seconds. Any longer than this will not obtain a further reduction in starting current.

Wiring

The soft starter should be wired in series between the cutter motor contactor and the compressor.

Options and Accessories

11. Tables & Charts

TABLES & CHARTS

P24AL SPECIFICATIONS, 400/460 Volt-3 Phase- 50/60Hz

Tube Size	inches (cm)	1 (2.54)	1 1/4 (3.17)	1 1/2 (3.18)
Nominal Capacity⁽¹⁾	Tons/day (M Tons/day)	21.4 (19.3)	22.4 (20.2)	16.6 (15.0)
Overall Dimensions (LxWxH)	Feet (meters)	5x5.5x14.5 (1.5x1.7x4.4)	5x5.5x16 (1.5x1.7x4.8)	5x5.5x16 (1.5x1.7x4.8)
Shipping Weight	lbs (Kg)	5,800 (2,630)	6,200 (2,810)	6,000 (2,720)
Operating Weight	lbs (Kg)	7,150 (3,240)	7,700 (3,490)	7,500 (3,400)
Refrigerant Charge (R-717)⁽²⁾	lbs (Kg)	500 (227)	500 (227)	500 (227)
Total FLA⁽³⁾		9.1	9.1	9.1
Maximum Fuse		15	15	15
Minimum Ampacity		7.6	7.6	7.6
System Requirements				
- Dedicated Compressor⁽⁴⁾	Tons (KW)	43.6 (154)	40.5 (143)	28.3 (100)
- Average Refrigeration⁽⁴⁾	Tons (KW)	35.0 (123)	34.9 (122)	25.5 (90)
- Peak refrigeration⁽⁴⁾	Tons (KW)	64.8 (228)	68.2 (240)	60.5 (212)
-makeup⁽⁵⁾	gpm (m³/Hr)	4.71 (1.1)	4.71 (1.1)	4.38 (1.0)
- blowdown per harvest	Gallons (L)	72 (272)	72 (272)	72 (272)
Connection Sizes				
-makeup water	FPT	3/4"	3/4"	3/4"
-tank drain	FPT	2"	2"	2"
-tank overflow	FPT	3"	3"	3"
-flush water	FPT	3/4"	3/4"	3/4"
-suction	Flanged	3"	3"	3"
-liquid feed	FPT/Socket	3/4"	3/4"	3/4"
-thaw gas	Flanged	2"	2"	2"
Compressor -HP-KW-FLA	Dedicated only	60 - 44.7 - 77	60 - 44.7 - 77	60 - 44.7 - 77
Water Pump -HP-KW-FLA		3 - 2.2 - 4.1	3 - 2.2 - 4.1	3 - 2.2 - 4.1
Cutter Motor -HP-KW-FLA		1 - 0.75 - 2.0	1 - 0.75 - 2.0	1 - 0.75 - 2.0
THR at Pulldown	Btu/hr (kW)	919,000 (269.3)	853,000 (250.0)	596,000 (174.6)

(1) Nominal capacity is based on 70°F makeup water, 16°F suction temperature, 100°F condensing temperature, 70°F ambient, and 25% blowdown.

(2) For evaporator only. Dedicated system charge is 1,000 lbs., (454Kgs).

(3) FLA for 460 volt models is approximately 1/2 that of 230 volt models. Total FLA does not include cooling tower or auxiliary equipment.

(4) Compressor Requirements is based on 16°F suction temperature, 100°F condensing temperature, 70°F ambient, and 25% blowdown.

(5) Makeup water is maximum value and includes 25% blowdown, each cycle.

Vogt reserves the right to change designs and specifications without notice.

Table 11-1

P34AL SPECIFICATIONS, 400/460 Volt-3 Phase- 50/60Hz

Tube Size	inches (cm)	1 (2.54)	1 1/4 (3.17)	1 1/2 (3.18)
Nominal Capacity⁽¹⁾	Tons/day (M Tons/day)	39.2 (35.6)	40.7 (37.0)	31.0 (28.2)
Overall Dimensions (LxWxH)	Feet (meters)	7x7x14.5 (2.1x2.1x4.4)	7x7x16 (2.1x2.1x4.8)	7x7x16 (2.1x2.1x4.8)
Shipping Weight	lbs (Kg)	9,400 (4,260)	10,000 (4,530)	9,600 (4,350)
Operating Weight	lbs (Kg)	10,450 (4,740)	11,400 (5,170)	11,200 (5,080)
Refrigerant Charge (R-717)⁽²⁾	lbs (Kg)	950 (431.0)	950 (431.0)	950 (431.0)
Total FLA⁽³⁾		17.0	9.1	9.1
Maximum Fuse		30	15	15
Minimum Ampacity		17.5	7.6	7.6
System Requirements				
- Dedicated Compressor⁽⁴⁾	Tons (KW)	87.9 (309)	81.9 (288)	58.6 (206)
- Average Refrigeration⁽⁴⁾	Tons (KW)	71.1 (250)	70.9 (249)	52.8 (186)
- Peak refrigeration⁽⁴⁾	Tons (KW)	126.6 (445)	131.8 (463)	118.8 (418)
-makeup⁽⁵⁾	gpm (m ³ /Hr)	8.1 (1.8)	8.9 (2.0)	8.0 (1.8)
- blowdown per harvest	Gallons (L)	104 (393)	104 (393)	104 (393)
Connection Sizes				
-makeup water	FPT	1"	1"	1"
-tank drain	FPT	2"	2"	2"
-flush water	FPT	3/4"	3/4"	3/4"
-tank overflow	FPT	3"	3"	3"
-suction	Flanged	4"	4"	4"
-liquid feed	FPT/Socket	1"	1"	1"
-thaw gas	Flanged	2"	2"	2"
Compressor -HP-KW-FLA	Dedicated	125 - 93.2 - 156	125 - 93.2 - 156	125 - 93.2 - 156
Water Pump - HP-KW-FLA		10 - 7.4 - 12.0	3 - 2.2 - 4.1	3 - 2.2 - 4.1
Cutter Motor - HP-KW-FLA		2 - 1.5 - 3.2	2 - 1.5 - 3.2	2 - 1.5 - 3.2
THR	Btu/hr (kW)	1,850,000 (542.0)	1,724,000 (505.2)	1,234,000 (362.0)

(1) Nominal capacity is based on 70°F makeup water, 16°F suction temperature, 100°F condensing temperature, 70°F ambient, and 25% blowdown.

(2) For evaporator only. Dedicated system charge is 1,000 lbs., (454Kgs).

(3) FLA for 460 volt models is approximately 1/2 that of 230 volt models. Total FLA does not include cooling tower or auxiliary equipment.

(4) Compressor Requirements is based on 16°F suction temperature, 100°F condensing temperature, 70°F ambient, and 25% blowdown.

(5) Makeup water is maximum value and includes 25% blowdown. each cycle.

Vogt reserves the right to change designs and specifications without notice.

Table 11-2

TABLES & CHARTS

Make-Up Water Temp. °F	Cylinder Ice			Crushed Ice		
	Tube Size			Tube Size		
	1"	1 1/4"	1 1/2"	1"	1 1/4"	1 1/2"
40	5.25	5.59	5.18	6.30	6.98	6.47
50	4.96	5.26	4.88	6.20	6.57	6.1
60	4.71	4.97	4.62	5.88	6.21	5.77
70	4.48	4.71	4.38	5.60	5.88	5.47
80	4.27	4.48	4.16	5.34	5.60	5.20
90	4.08	4.27	3.97	5.10	5.34	4.96

Includes 25% blowdown per cycle

Table 11-3
P24AL Make-Up Water Usage (gpm)

Make-Up Water Temp. °F	Cylinder Ice			Crushed Ice		
	Tube Size			Tube Size		
	1"	1 1/4"	1 1/2"	1"	1 1/4"	1 1/2"
40	9.47	10.57	9.62	11.83	13.21	12.02
50	8.94	9.95	9.05	11.17	12.43	11.31
60	8.47	9.39	8.55	10.58	11.73	10.68
70	8.04	8.90	8.10	10.05	11.12	10.13
80	7.66	8.45	7.69	9.57	10.56	9.61
90	7.31	8.04	7.32	9.13	10.05	9.15

Includes 25% blowdown per cycle

Table 11-4
P34AL Make-Up Water Usage (gpm)

			Suction Pressure (psig)		Discharge Pressure (psig)		Harvest Times (secs)			Ice per cycle Average (lbs)	Freeze Time (minutes)				
			End of Freeze	End of Thaw	End of Freeze	End of Thaw	First Ice	All Ice Out	Total Harvest		Water Temperature (deg. F)				
										90	80	70	60	50	
60 HZ	C	1"	25	56	175	63	27	105	150	450	15.7	14.4	13.1	11.8	10.5
	Y	1 1/4"	22	54	180	54	34	125	165	650	21.6	20.0	18.3	16.6	15.0
	L	1 1/2"	19	53	180	66	40	140	180	750	23.2	21.5	19.7	18.0	16.3
	C	1"	32	56	175	63	11	191	212	260	8.7	7.9	7.0	6.1	5.6
	R	1 1/4"	29	54	180	54	13	211	234	375	9.3	8.31	7.5	6.8	6.1
	U	1 1/2"	26	53	180	66	14	226	250	433	12.9	12.0	11.2	10.4	9.4
50 HZ	C	1"	25	56	175	63	27	105	150	450	15.7	14.4	13.1	11.8	10.5
	Y	1 1/4"	22	54	180	54	34	125	165	650	21.6	20.0	18.3	16.6	15.0
	L	1 1/2"	19	53	180	66	40	140	180	750	23.2	21.5	19.7	18.0	16.3
	C	1"	32	56	175	63	11	191	212	260	8.7	7.9	7.0	6.1	5.6
	R	1 1/4"	29	54	180	54	13	211	234	375	9.3	8.31	7.5	6.8	6.1
	U	1 1/2"	26	53	180	66	14	226	250	433	12.9	12.0	11.2	10.4	9.4

**Table 11-5
P24AL Normal Operating Vitals**

			Suction Pressure (psig)		Discharge Pressure (psig)		Harvest Times (secs)			Ice per cycle Average (lbs)	Freeze Time (minutes)				
			End of Freeze	End of Thaw	End of Freeze	End of Thaw	First Ice	All Ice Out	Total Harvest		Water Temperature (deg. F)				
										90	80	70	60	50	
60 HZ	C	1"	25	53	180	66	60	180	260	850	13.4	12.5	11.7	10.8	10.0
	Y	1 1/4"	22	54	180	70	70	196	270	1300	17.5	15.5	13.5	13.0	12.0
	L	1 1/2"	18	54	190	65	50	190	265	1350	24	22	21.5	21	20
	C	1"	32	56	175	63	34	266	300	491	12.0	11.2	10.3	9.4	8.9
	R	1 1/4"	29	54	180	54	44	282	326	751	12.6	11.6	10.8	10.1	9.4
	U	1 1/2"	25	53	180	66	24	276	300	780	16.2	15.3	14.5	13.7	12.7
50 HZ	C	1"	25	53	180	66	60	180	260	850	13.4	12.5	11.7	10.8	10.0
	Y	1 1/4"	22	54	180	70	70	196	270	1300	17.5	15.5	13.5	13.0	12.0
	L	1 1/2"	18	54	190	65	50	190	265	1350	24	22	21.5	21	20
	C	1"	32	56	175	63	34	266	300	491	12.0	11.2	10.3	9.4	8.9
	R	1 1/4"	29	54	180	54	44	282	326	751	12.6	11.6	10.8	10.1	9.4
	U	1 1/2"	25	53	180	66	24	276	300	780	16.2	15.3	14.5	13.7	12.7

**Table 11-6
P34AL Normal Operating Vitals**

TABLES & CHARTS

RECOMMENDED SPARE PARTS LIST

Vogt Model P24AL and P34AL Tube-Ice® Machine

QTY	P24A PART NO.	P34A PART NO.	DESCRIPTION
1	12A-7503E22000000	12A-7503E22000000	Thaw timer 208/230
1	12A-2590G12000000	12A-2590G12000000	Suction pressure gage 30"-150#
1	12A-2590G13000000	12A-2590G13000000	Discharge pressure gage 30"-300#
1	12A-4200H06010000	12A-4200H06010000	Roberts float valve 3/4"
1	12A-4200HP0100000	12A-4200HP0100000	10" float valve stem
1	12A-4200HP0200000	12A-4200HP0200000	Float for Roberts 6"
1	12A-2600G08000000	12A-2600G10000000	Freezer cover gasket (P24-27" o.d., P34-37" o.d.)
1	12A-2600G09000000	12A-2600G11000000	Water tank gasket (P24-30" o.d., P34-40" o.d.)
1	12A-2625G03000000	12A-2625G03000000	Gage glass 1/2" x 28 1/8" lg.
2	12A-4199V26000000	12A-4199V26000000	Gage glass O-ring
1	12A-7500E24000000	12A-7500E24000000	Switch assembly for float switch
1	12--6229---000000	12--6229---000000	Coil for Hansen Solenoid
1*	12A-7503E04000000	12A-7503E04000000	Freezing timer, 60 minute
1	12A-2117C03000000	12A-2117C03000000	Freezer pressure switch Asco #PA16A
1	12A-2117T03000000	12A-2117T03000000	Transducer for above control Asco RE10A44
2**	12A-7504E01000000	12A-7504E01000000	Fuse 10 amp.
3**	12A-7504E06000000	12A-7504E06000000	Fuse 15 amp.
3**	12A-7504E03000000	12A-7504E03000000	Fuse 20 amp.
1**	12A-7515E16000000	12A-7515E16000000	6 Amp Circuit Breaker
1**	12A-7515E08000000	12A-7515E08000000	15 Amp Circuit Breaker
1**	12A-7515E09000000	12A-7515E09000000	30 Amp Circuit Breaker
144	12B-2185V12000000	12B-2185V12000000	Water distributors 1 1/2" (P34-306 Req'd)
198	12B-2185V22000000	12B-2185V22000000	Water distributors 1 1/4" (P34-420 Req'd)
264	12B-2185V32000000	12B-2185V32000000	Water distributors 1" (P34-564 Req'd)
as req'd	12--6531RED000000	12--6531RED000000	Red vent tubes (one per water distributor)
1	12A-4200A06020000	12A-4200A06020000	Flush valve J/E solenoid
1	12B-2615D03000000	12B-2615D05000000	P24 drive gear--aluminum, bronze
1	12--6229---000000	12--6229---000000	Coil for HS7 Hansen solenoid
1	12B-2060B04000000	12B-2060B01000000	Hub for drive gear

* Unit can be replaced by 12A-7503E03000. Digital style timer.

** Later models contain circuit breakers rather than fuses.

TO ORDER SPARE PARTS, PLEASE CONTACT YOUR DISTRIBUTOR.

**TEMPERATURE - PRESSURE CHART
FOR COMMON REFRIGERANTS (°F-psig)**

DegF	R-12	R-22	R-502	R-134a	R-404A	R-717	MP-39	DegF	R-12	R-22	R-502	R-134a	R-404A	R-717	MP-39
-50	-7.6	-3.0	0.2	-9.0	0.0	-7.0	-9.1	50	46.7	84.0	97.4	45.5	102.9	74.2	45.3
-48	-7.2	-2.4	0.7	-8.7	0.8	-6.5	-8.7	52	48.8	87.3	101.0	47.7	109.0	77.7	60.0
-46	-6.8	-1.7	1.5	-8.3	1.6	-6.0	-8.3	54	51.0	90.8	104.8	50.1	113.0	81.3	62.0
-44	-6.3	-1.0	2.3	-8.0	2.5	-5.4	-7.9	56	53.2	94.3	108.6	52.3	117.0	84.9	65.0
-42	-5.8	-0.2	3.2	-7.6	3.4	-4.9	-7.4	58	55.4	97.9	112.4	55.0	121.0	88.7	68.0
-40	-5.4	0.5	4.1	-7.1	5.5	-4.3	-7.1	60	57.7	101.6	116.4	57.5	125.0	92.6	70.0
-38	-4.9	1.3	5.0	-6.7	6.5	-3.6	-6.6	62	60.1	105.4	120.4	60.1	130.0	96.6	73.0
-36	-4.4	2.2	6.0	-6.3	7.5	-3.0	-6.1	64	62.5	109.3	124.6	62.7	134.0	100.7	76.0
-34	-3.8	3.0	7.0	-5.8	8.6	-2.3	-5.6	66	65.0	113.2	128.8	65.5	139.0	104.9	79.0
-32	-3.3	4.0	8.1	-5.3	9.7	-1.6	-5.2	68	67.6	117.3	133.2	68.3	144.0	109.3	82.0
-30	-2.7	4.9	9.2	-4.8	10.8	-0.8	-4.4	70	70.2	121.4	137.6	71.2	148.0	113.7	85.0
-28	-2.1	5.9	10.3	-4.2	12.0	0.0	-4.1	72	72.9	125.7	142.2	74.2	153.0	118.3	89.0
-26	-1.5	6.9	11.5	-3.8	13.2	0.8	-3.4	74	75.6	130.0	146.8	77.2	158.0	123.1	92.0
-24	-0.8	7.9	12.7	-3.0	14.5	1.7	-2.9	76	78.4	134.5	151.5	80.3	164.0	127.9	95.0
-22	-0.1	9.0	14.0	-2.4	15.8	2.6	-2.2	78	81.3	139.0	156.3	83.5	169.0	132.8	99.0
-20	0.6	10.1	15.3	-1.8	17.1	3.5	-1.7	80	84.2	143.6	161.2	86.8	174.0	137.9	102.0
-18	1.3	11.3	16.7	-1.1	18.5	4.5	-1.0	82	87.2	148.4	166.2	90.2	180.0	143.2	106.0
-16	2.1	12.5	18.1	-0.4	20.0	5.6	-0.2	84	90.2	153.2	171.4	93.6	185.0	148.5	109.0
-14	2.8	13.8	19.5	0.3	21.5	6.7	0.4	86	93.3	158.2	176.6	97.1	191.0	154.1	113.0
-12	3.7	15.1	21.0	1.1	23.0	7.8	1.4	88	96.5	163.2	181.9	100.7	197.0	159.7	117.0
-10	4.5	16.5	22.6	1.9	24.6	8.9	2.2	90	99.8	168.4	187.4	104.4	203.0	165.5	121.0
-8	5.4	17.9	24.2	2.8	26.3	10.2	3.1	92	103.1	173.7	192.9	108.2	209.9	171.4	125.0
-6	6.3	19.3	25.8	3.6	28.0	11.4	3.9	94	106.5	179.1	198.6	112.1	215.0	177.5	129.0
-4	7.2	20.8	27.5	4.5	29.8	12.8	4.8	96	110.0	184.6	204.3	116.1	222.0	183.7	133.0
-2	8.2	22.4	29.3	5.5	31.6	14.2	5.7	98	113.5	190.2	210.2	120.1	229.0	190.1	138.0
0	9.2	24.0	31.1	6.5	33.5	15.6	6.7	100	117.2	195.9	216.2	124.3	235.0	196.1	142.0
2	10.2	25.6	32.9	7.5	35.6	17.1	7.7	102	120.9	201.8	222.3	128.5	242.0	203.3	146.0
4	11.2	27.3	34.9	8.5	37.4	18.6	8.8	104	124.7	207.7	228.5	132.9	249.0	210.2	151.0
6	12.3	29.1	36.9	9.6	39.4	20.3	9.9	106	128.5	213.8	234.9	137.3	256.0	217.2	156.0
8	13.5	30.9	38.9	10.8	41.6	21.9	11.0	108	132.4	220.0	241.3	142.8	264.0	224.4	160.0
10	14.6	32.8	41.0	12.0	43.9	23.7	12.2	110	136.4	226.4	247.9	146.5	271.0	231.7	165.0
12	15.8	34.7	43.2	13.1	46.0	25.4	13.4	112	140.5	232.8	254.6	151.3	279.0	239.2	170.0
14	17.1	36.7	45.4	14.4	48.3	27.4	14.6	114	144.7	239.4	261.5	156.1	286.0	246.9	175.0
16	18.4	38.7	47.7	15.7	50.7	29.3	15.9	116	148.9	246.1	268.4	161.1	294.0	254.8	180.0
18	19.7	40.9	50.0	17.0	53.1	31.3	17.2	118	153.2	252.9	275.5	166.1	302.0	262.8	185.0
20	21.0	43.0	52.5	18.4	55.6	33.3	18.6	120	157.7	259.9	282.7	171.3	311.0	271.0	191.0
22	22.4	45.3	54.9	19.9	58.2	35.5	20.0	122	162.2	267.0	290.1	176.6	319.0	279.4	196.0
24	23.9	47.6	57.5	21.4	59.9	37.7	21.5	124	166.7	274.3	297.6	182.0	328.0	288.0	202.0
26	25.4	49.9	60.1	22.9	63.6	40.0	23.0	126	171.4	281.6	305.2	187.5	336.0	296.7	207.0
28	26.9	52.4	62.8	24.5	66.5	42.4	24.6	128	176.2	289.1	312.9	193.1	345.0	305.7	213.0
30	28.5	54.9	65.6	26.1	69.4	44.8	26.2	130	181.0	296.8	320.8	198.9	354.0	314.8	219.0
32	30.1	57.5	68.4	27.8	72.3	47.4	27.9	132	185.9	304.6	328.9	204.7	364.0	324.2	225.0
34	31.7	60.1	71.3	29.5	75.4	50.0	29.6	134	191.0	312.5	337.1	210.7	373.0	333.7	231.0
36	33.4	62.8	74.3	31.3	78.5	52.7	31.3	136	196.2	320.6	345.4	216.8	383.0	343.4	237.0
38	35.2	65.6	77.4	33.2	81.8	55.5	33.2	138	201.3	328.9	353.9	223.0	392.0	353.4	243.0
40	36.9	68.5	80.5	35.1	85.1	58.4	35.0	140	206.6	337.3	362.6	229.4	402.0	363.5	250.0
42	38.8	71.5	83.8	37.0	88.5	61.3	37.0	142	212.0	345.8	371.4	235.8	412.0	373.8	256.0
44	40.7	74.5	87.0	39.1	91.9	64.4	39.0	144	217.5	354.5	380.4	242.4	423.0	384.4	263.0
46	42.7	77.6	90.4	42.0	95.5	67.6	41.0	146	223.1	363.4	389.5	249.2	434.0	395.2	269.0
48	44.7	80.7	93.9	43.3	99.2	70.8	43.1	148	228.8	372.3	398.9	256.0	444.0	406.1	277.0
50	46.7	84.0	97.4	45.5	102.9	74.2	45.3	150	234.6	381.5	408.4	263.0	449.0	432.0	283.0

TABLE 11-7
All pressures are in lbs/in² gage (psig).

TABLES & CHARTS

REFERENCE INFORMATION**CONVERSION FACTORS: English to Metric**

To Convert	From	To	Multiply by
Area	ft ²	m ²	9.2903e-2
	in ²	m ²	6.416 e-4
Energy	BTU	Joule (J)	1054.48
	hp	BTU/Hr	2546.2
	kW	hp	1.34
Length	ft.	m.	0.3048
	in.	m.	0.0254
Pressure	lbf/ft ²	Paschals	47.88
	lbf/in ² (psi)	Paschals	6894.76
	in. Hg	psi	0.491
	in H ₂ O	psi	0.03612
Temperature	°F	°C	$T_C = 5/9 * (T_F - 32)$
	°C	°F	$T_F = (9/5 * T_C) + 32$
Volume	ft ³	m ³	2.8317e-2
	gal(U.S.)	m ³	3.7854e-3
	ft ³	gal(U.S.)	7.48

TABLE 11-8**CONSTANTS**

Specific heat of Water	1 BTU/(lbm °F)
Specific heat of Air	4.19 kJ/(kg °C) 0.24 BTU/(lbm °F)
Tube-Ice Density	32-35 lbs/ft ³
Ice Latent Heat	144 BTU/hr
Water Sensible Heat	1 BTU/(lb °F)
Ice Melting Effect (IME) 1 Ton Refrigeration	12,000 BTU/hr
Atmospheric pressure	14.7 psia
Weight of Water	62.4 lbs/ft ³ 8.33 lbs/gal
1 gpm water	12013 lb/day
Weight of air	0.0749 lbs/ft ³ 0.0100 lbs/gal
1 Horsepower	2545.6 BTU/hr
1 Kilowatt	1.34 horsepower
Gravitational accel.	9.81 m ² /sec

TABLE 11-9

Appendix A

SECTION 1: CHEMICAL PRODUCT & COMPANY IDENTIFICATION

CHEMICAL NAME:	Anhydrous Ammonia	TRADE NAMES/SYNONYMS	Ammonia
PRODUCT CODE:	5B81-83		
MANUFACTURER AND/OR DISTRIBUTOR:	LaRoche Industries Inc. 1100 Johnson Ferry Rd., NE Atlanta, Ga. 30342	EMERGENCY TELEPHONE NUMBERS:	Transportation (CHEMTREC): (800) 424-9300 Environmental/Health/Safety: (800) 528-4963 Customer Service: (800) 491-7987

SECTION 2: COMPOSITION/INFORMATION ON INGREDIENTS

CHEMICAL	FORMULA	% BY WEIGHT		CAS	OSHA PEL	NIOSH REL / ACGIH TLV	IDLH
		C-grade	P-grade				
Ammonia	NH ₃	99.5	99.995	7664-41-7	50 ppm (TWA)	25 ppm (TWA) 35 ppm (STEL)	300 ppm
Water	H ₂ O	0.4	33 ppm	7732-18-5	None	None	None
Oil	----	0.1	2 ppm	-----	None	None	None

SECTION 3: HAZARDS IDENTIFICATION

EMERGENCY OVERVIEW: 1) Colorless gas or compressed liquid with extremely pungent odor 2) Liquid ammonia reacts violently with water. Vapor cloud is produced 3) Avoid contact with liquid and vapor 4) Stay upwind and use water spray to absorb vapor 5) Not flammable under conditions likely to be encountered outdoors 6) Stop discharge if possible

POTENTIAL HEALTH EFFECTS:

ROUTES OF ENTRY: Inhalation, Skin Contact, Eye Contact, Ingestion **TARGET ORGANS:** Eyes, skin and respiratory system

EYE CONTACT: Exposure to liquid or high concentrations of vapor can cause painful, instant and possibly irreversible damage to tissue such as the conjunctiva, cornea and lens.

SKIN CONTACT: Prolonged contact with high concentrations can cause painful tissue damage, frostbite and serious chemical burns.

INHALATION: Depending on exposure concentration and duration, effects can vary from none or only mild irritation, to obstruction of breathing from laryngeal and bronchial spasm, to edema and severe damage of the mucous membranes of the respiratory tract with possible fatal results. Latent edema and residual reduction in pulmonary function may occur.

INGESTION: Tissue damage, chemical burns, nausea and vomiting can occur. Ammonia is a gas under normal atmospheric conditions and ingestion is unlikely.

CARCINOGENICITY: NTP? No IARC? No OSHA? No

SECTION 4: FIRST AID MEASURES

EYE CONTACT: Flush with large amount of water for at least 15 minutes then immediately seek medical aid.

SKIN CONTACT: Immediately flush with large quantities of water for at least 15 minutes while removing clothing. Clothing frozen to the skin should be thawed with water before removal. Seek immediate medical aid.

INHALATION: Remove from exposure. If breathing has stopped or is difficult, administer artificial respiration or oxygen as needed. Seek immediate medical aid.

INGESTION: Do not induce vomiting. Have the victim drink large quantities of water if conscious. Immediately seek medical aid. Never give anything by mouth to an unconscious person.

SECTION 5: FIRE FIGHTING MEASURES

FLASH POINT(method used): Not Applicable **FLAMMABLE LIMITS:** 16-25% in air

EXTINGUISHING MEDIA: With a source of ignition, ammonia will burn in the range of 16-25% in air. Stop flow of gas or liquid.

SPECIAL FIRE FIGHTING PROCEDURES: Move containers from fire zone if possible; if not, use water to cool fire exposed containers. Use water spray to control vapors. Do not put water directly on liquid ammonia. Personnel must be equipped with appropriate protective clothing and respiratory protection.

NFPA HAZARD CLASSIFICATION: Health: 3 Flammability: 1 Reactivity: 0 (least-0 ↔ 4-highest)

SECTION 6: ACCIDENTAL RELEASE MEASURES

Release of 100 lbs. or more of ammonia within 24 hours must be immediately (within minutes) reported to the National Response Center at 1-800-424-8802, as well as appropriate local and state agencies. **Suggested Local Action:** Stop leak if feasible. Avoid breathing ammonia. Evacuate personnel not equipped with protective clothing and equipment. Use copious amounts of water spray or fog to absorb ammonia vapor. DO NOT put water on liquid ammonia. Contain run-off to prevent ammonia from entering a stream, lake, sewer, or ditch. Any release of this material, during the course of loading, transporting, unloading or temporary storage, must be reported to U.S. D.O.T. as required by CFR 171.15 and 171.16.

SECTION 7: HANDLING AND STORAGE

Refer to the ANSI K61.1 standard for storage and handling information. Protect containers from physical damage and temperatures exceeding 120°F. Use only approved storage systems. Zinc, copper, silver, cadmium and their alloys must not be used in ammonia systems since they can be rapidly corroded by it. Avoid hydrostatic pressure, which can cause equipment rupture, by adhering to proper filling procedures and the use of hydrostatic pressure relief valves where appropriate.

SECTION 8: EXPOSURE CONTROLS/PERSONAL PROTECTION

RESPIRATORY PROTECTION: Respiratory protection approved by NIOSH/MSHA for ammonia must be used when exposure limits are exceeded. Whether a chemical cartridge respirator or a self-contained breathing apparatus is sufficient for effective respiratory protection depends on the type and magnitude of exposure.

EYE PROTECTION: Chemical splash goggles, approved for use with ammonia, must be worn to prevent eye contact with liquid or vapor. A face shield should be used for increased protection from contact with liquid.

VENTILATION: Local positive pressure and/or exhaust ventilation should be used to reduce vapor concentrations in confined spaces. Ammonia vapor, being lighter than air, can be expected to dissipate to the upper atmosphere. Ammonia concentrations may also be reduced by the use of an appropriate absorbent or reactant material.

OTHER EQUIPMENT: Emergency eye wash stations and deluge safety showers must be available in the work area. Post a list of emergency response contacts and telephone numbers.

SECTION 9: PHYSICAL AND CHEMICAL PROPERTIES

Boiling Point: -28.1°F

Vapor Pressure: 4802.9 mm Hg @60°F

Vapor Density: 0.60 @ 32°F (Air=1)

Solubility In Water: High

Percent Volatile By Volume: 100%

pH: Approx. 11.6 for 1 N Soln. in water

Melting Point: -107.9°F

Specific Gravity: 0.62 @ 60°F (water=1)

Appearance: Colorless (pungent) gas

SECTION 10: STABILITY AND REACTIVITY

STABILITY: Material generally considered stable. However, heating above ambient temperatures causes the vapor pressure of ammonia to increase rapidly.

INCOMPATIBILITY (Materials to Avoid): Ammonia can react violently with strong acids. Under certain conditions, ammonia reacts with bromine, chlorine, fluorine or iodine to form compounds which explode spontaneously. Reactions of ammonia with gold, silver or mercury to form explosive fulminate-like compounds have been reported.

HAZARDOUS DECOMPOSITION PRODUCTS: Hydrogen on heating to over 850°F. The decomposition temperature may be lowered to 575°F by contact with certain metals such as nickel.

HAZARDOUS POLYMERIZATION: Will not occur. **CONDITIONS TO AVOID:** Not applicable.

SECTION 11: TOXICOLOGICAL INFORMATION

Ammonia is a strong alkali and readily damages all body tissues. Ammonia is not a cumulative metabolic poison.

SECTION 12: ECOLOGICAL INFORMATION

Aquatic Toxicity: 2.0-2.5 ppm/1-4 days/goldfish & yellow perch/LC; 60-80 ppm/3 days/crawfish/LC₁₀₀; 8.2 ppm/96hr/fatheadminnow/TLM

Waterfowl Toxicity: 120 ppm

Biochemical Oxygen Demand: Not pertinent

Food Chain Concentration Potential: None

SECTION 13: DISPOSAL CONSIDERATIONS

Recover ammonia if feasible. Otherwise, let ammonia evaporate if appropriate. Only personnel experienced in ammonia spills should add water to liquid ammonia. Dispose of diluted ammonia as a fertilizer or in an industrial process. For Hazardous Waste Regulations call 1-800-424-9346, the RCRA Hotline.

SECTION 14: TRANSPORT INFORMATION

	Domestic Shipments	International Shipments
Proper shipping name:	Ammonia, Anhydrous, Liquefied	Ammonia, Anhydrous, Liquefied
DOT Hazard Class:	2.2 (nonflammable gas)	2.3 (poison gas)
Identification Number:	UN1005	UN1005
Packing Group:	None	None

SECTION 15: REGULATORY INFORMATION

NOTICE: This product is subject to the reporting requirements of SARA (1986, Section 313 of Title III) and 40 CFR Part 370.

OSHA HAZARD COMMUNICATION RULE, 29 CFR 1910.1200: Ammonia is considered a hazardous chemical.

OSHA HAZARD COMMUNICATION RULE, 29 CFR 1910.1200: Ammonia is considered a hazardous chemical.

EMERGENCY PLANNING AND COMMUNITY RIGHT-TO-KNOW ACT (SARA, TITLE III): Section 302

Extremely Hazardous Substance: Yes; Section 311/312 Hazardous Categories: Immediate (acute) health hazards;

Section 313 Toxic Chemical: Yes

CERCLA/SUPERFUND, 40 CFR 117,302: This product contains ammonia which if released to the environment in quantities of 100 lbs. or more requires notification to the National Response Center in Washington, DC at 1-800-424-8802.

WHMIS: One Percent (1%) **CALIFORNIA PROPOSITION 65:** Reproductive: No Carcinogen: No

OSHA PROCESS SAFETY MANAGEMENT, 29 CFR 1910.119: This product is subject to the Process Safety Management requirements of 29 CFR 1910.119 if maintained on-site in quantities of 10,000 lbs. or greater.

EPA CHEMICAL ACCIDENT RELEASE PREVENTION, 40 CFR PART 68: This product is subject to the Risk Management Plan requirements of 40 CFR Part 68 if maintained on-site in quantities of 10,000 lbs. or greater.

DRINKING WATER: Maximum use dosage in potable water is 5 mg/l.

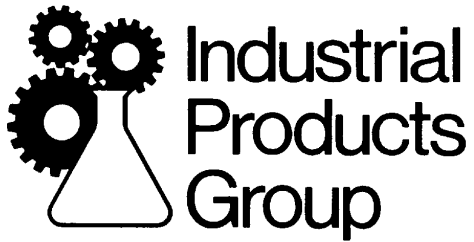

Anhydrous Ammonia Safety

LaRoche INDUSTRIES INC.

FOREWORD

Ammonia (frequently called anhydrous ammonia) is one of the most valuable and versatile chemical compounds in today's modern world. For example, it finds wide application in food production and processing, textile and chemical manufacturing, refrigeration, metal treating and pollution abatement.

An ever increasing use of ammonia has been accompanied by a corresponding growth in the need for the dissemination of knowledge regarding ammonia safety among persons working with ammonia under either normal or emergency conditions. Recognizing this need, LaRoche Industries has prepared this booklet which contains a selected collection of helpful information and suggestions for the ammonia user and for safety personnel. The suggestions may be employed as an aid in the preparation of the ammonia user's own comprehensive safety program and should be altered or augmented in accordance with individual requirements.

Anyone working with ammonia, either directly or indirectly, whether at a supervisory or non-supervisory level, has a responsibility not only to be thoroughly familiar with basic ammonia safety principles, but also to observe faithfully all necessary precautions and to react promptly and appropriately should an emergency arise. Readers of this booklet will find answers to questions most often asked regarding general properties, potential hazards, exposure effects, personal protective and safety equipment, first aid procedures and methods of dealing with emergencies involving ammonia. Information as to the manufacture, transportation, storage or application of ammonia is not detailed.

Persons requiring any information regarding ammonia not covered in this booklet are urged to consult with LaRoche Industries or with the Compressed Gas Association, Inc., Arlington, VA or The Fertilizer Institute, Washington, DC for assistance.

PLEASE NOTE

The information and suggestions compiled in this booklet are derived from sources believed to be reputable and reliable. HOWEVER, LAROCHE INDUSTRIES SUPPLIES THIS BOOKLET MERELY AS A GRATUITOUS SERVICE AND MAKES NO WARRANTY OR GUARANTEE OF RESULTS, EXPRESSED OR IMPLIED, AND ASSUMES NO LIABILITY IN CONNECTION WITH THE INFORMATION AND SUGGESTIONS HEREIN. No assumption shall be made as to the absolute correctness or sufficiency of any representation in the booklet or that certain circumstances may not warrant or require modified or additional precautions or actions.

This booklet should not be confused with federal, state or municipal regulations, insurance requirements or national safety codes, although some statements may be similar or identical.

CONTENTS

	Page
FOREWORD	i
GENERAL	1
PRIMARY HAZARDS	2
OTHER HAZARDS	2
CHEMICAL	2
THERMAL EXPANSION	2
HUMAN PHYSIOLOGICAL EFFECTS	2
EXPOSURE LIMITS	3
PERSONAL PROTECTIVE EQUIPMENT	3
EMERGENCY PROTECTIVE AND SAFETY EQUIPMENT	3
SAFETY SHOWER	3
RESPIRATORY DEVICES	3
PROTECTIVE CLOTHING	4
RESCUE HARNESS	4
WATER SYSTEM	4
STRETCHER AND BLANKETS	4
FIRST AID PROCEDURES	4
INHALATION	5
EYES	5
SKIN AND MUCOSA	5
INTERNAL	5
EMERGENCY MEASURES	6
LEAK DETECTION	7
LEAK CONTROL	8
EQUIPMENT OR PIPING	8
VALVE	8
PRESSURE RELIEF DEVICE	8
STORAGE TANK	8
SHIPPING CONTAINER	9
FIRE EXPOSURE	9
EMPLOYEE SAFETY TRAINING	10

TABLES

TABLE 1. VAPOR PRESSURE AND VOLUME OF LIQUID AMMONIA AT VARIOUS TEMPERATURES	1
TABLE 2. PHYSIOLOGICAL EFFECTS OF AMMONIA VAPOR	3
TABLE 3. TABLE OF DISTANCES TO EVACUATE	7

ANHYDROUS AMMONIA SAFETY

GENERAL

The term "anhydrous ammonia" appearing in the title of this booklet refers to the compound having the formula NH_3 , formed by the chemical combination of nitrogen and hydrogen. Whenever the term "ammonia" appears in this booklet, it should be understood as meaning anhydrous ammonia and not aqua ammonia, aqueous ammonia or ammonium hydroxide which are solutions of ammonia in water. Ammonium hydroxide solutions generally range in concentrations of ammonia from about 30% down to the 2 to 4% found in the well known household ammonia. These solutions are all commonly known as ammonia, but should never be confused with liquid anhydrous ammonia which has a much greater hazard potential. "Anhydrous" means "free from water".

At room temperature and atmospheric pressure, ammonia is a pungent, colorless gas approximately 40% lighter than air. Compressed and cooled, ammonia gas condenses to a colorless liquid about 68% as heavy as water. At atmospheric pressure, the liquid boils at -28F.

In a container, ammonia in the liquid form normally coexists with vapor. Temperature affects both the vapor pressure and volume of liquid ammonia.

As the temperature of the liquid rises, the vapor

above the liquid phase exerts increased pressure. It should be noted that the pressure observed within a container is NOT a measure of the quantity of the liquid present.

With increasing temperature, ammonia in the liquid phase expands. For example, in an ammonia cylinder at 65F loaded to its maximum allowable limit in accordance with Federal regulations, the vapor phase occupies about 12% of the total cylinder volume. This vapor space would be completely filled with liquid ammonia if its temperature were permitted to reach 145F. Upon further temperature rise, the cylinder will bulge and could rupture due to the internal hydrostatic pressure caused by the expanding liquid.

Because of these characteristics, ammonia containers should not be exposed to excessive heat. (See THERMAL EXPANSION and FIRE EXPOSURE.)

Under equilibrium conditions, the vapor pressure and volume of liquid ammonia vary with temperature as shown in Table 1.

TABLE 1. VAPOR PRESSURE AND VOLUME OF LIQUID AMMONIA AT VARIOUS TEMPERATURES

Temperature Degrees F	Vapor Pressure psig	Volume Gal./CWT
- 28	0.0	17.57
0	15.7	18.10
30	45.0	18.72
60	92.9	19.43
90	165.9	20.25
115	251.5	21.04
130	315.6	21.58

(Data derived from U. S. Bureau of Standards Circular No. 142.)

Ammonia is most frequently shipped by highway and rail and stored in pressure containers as a liquefied compressed gas at ambient temperatures. Ammonia in very large quantities is transported in high pressure pipelines at ambient temperatures and is shipped by barge or tanker as refrigerated liquid at - 28F and atmospheric pressure. When stored in large quantities, such as at a terminal, ammonia is generally refrigerated and kept in insulated tanks at - 28F.

PRIMARY HAZARDS

Ammonia acts as an irritant to human tissue in varying degrees depending upon concentration and exposure.

The pungent and distinctive odor of the vapor, even at low concentrations, provides adequate warning so that no person will voluntarily remain in concentrations which are hazardous. (See HUMAN PHYSIOLOGICAL EFFECTS.)

At the time of this printing ammonia is classified by the U.S. Department of Transportation as a NONFLAMMABLE GAS. Conditions favorable for ignition are seldom encountered in normal handling due to its narrow range of susceptibility to ignition. In the presence of a flame or spark at about 1200F, ammonia vapor will ignite, but only within the limited range of 16-25% of ammonia in air by volume. The heat generated by combustion is insufficient to maintain a flame which therefore will extinguish upon ignition source removal.

OTHER HAZARDS

CHEMICAL - As a chemical compound, ammonia is highly associated and stable at ordinary temperatures. At about 840F ammonia begins to dissociate with the formation of nitrogen and highly flammable hydrogen.

Ammonia will not corrode most of the common metals, but in the presence of water, ammonia will attack copper, zinc and alloys containing these elements. For this reason, materials of construction used for ammonia containers, fittings, piping and equipment are limited to steel and iron or certain non-ferrous alloys resistant to attack by ammonia.

Ammonia is a highly reactive chemical, forming salts with many inorganic and organic acids, usually with the release of heat. Under certain conditions, ammonia is known to react with bromine, chlorine, fluorine or iodine, to form compounds which explode spontaneously. Ammonia has been reported as reacting with gold, silver or mercury to form fulminate-like compounds which are explosive.

THERMAL EXPANSION - Liquid ammonia exhibits a high coefficient of cubical expansion. A given quantity of liquid ammonia therefore expands considerably in volume with a rise in temperature. (See Table 1.) For this reason, appropriate measures must be taken to avoid hydrostatic rupture of containers, piping or other equipment as could be caused by such expansion.

HUMAN PHYSIOLOGICAL EFFECTS

Ammonia is NOT a cumulative metabolic poison; ammonium ions are actually important constituents of living systems. Depending upon concentration and time, the effects of exposure to ammonia vapor vary from none or only mild irritation, to obstruction of breathing from laryngeal and bronchial spasm, to edema and severe damage of the mucous membranes of the respiratory tract with possible fatal results.

Ammonia in the presence of water is highly alkaline. Contact of the skin or mucosa with liquid ammonia or a high concentration of vapor can result in a caustic burn. Due to the great attraction of water to ammonia, water may be absorbed simultaneously from the tissue resulting in dehydration of the affected area.

Liquid ammonia boils at -28F under atmospheric conditions, acting as a refrigerant to remove heat from any warmer object it may be contacting. Accordingly, liquid ammonia in contact with the skin can cause frostbite.

Exposure levels of ammonia vapor which are tolerated by some persons may produce adverse reactions in others. Persons having chronic respiratory disease or persons who have shown evidence of undue sensitivity to ammonia should not be exposed to ammonia. Table 2 indicates human physiological response to various concentrations of ammonia in air upon inhalation.

TABLE 2. PHYSIOLOGICAL EFFECTS OF AMMONIA VAPOR

Effect	PPM Ammonia in Air by Volume
Least perceptible odor	5 ppm
Readily detectable odor	20-50 ppm
No discomfort or impairment of health for prolonged exposure	50-100 ppm
General discomfort and eye tearing; no lasting effect on short exposure	150-200 ppm
Severe irritation of eyes, ears, nose and throat; no lasting effect on short exposure	400-700 ppm
Coughing, bronchial spasms	1,700 ppm
Dangerous, less than 1/2 hour exposure may be fatal	2,000-3,000 ppm
Serious edema, strangulation, asphyxia, rapidly fatal	5,000-10,000 ppm
Immediately fatal	over 10,000 ppm

(From "Anhydrous Ammonia", Pamphlet G-2 Seventh Edition, Compressed Gas Association, Inc.)

EXPOSURE LIMITS

Occupational Safety and Health Administration (OSHA) regulations require that an employee's short term exposure limit (STEL) for ammonia not exceed a time-weighted average of 35 ppm ammonia in air by volume in any 15 minute period.

The American Conference of Government and Industrial Hygienists (ACGIH) has established an exposure limit of 25 ppm ammonia in air by volume as an 8 hour time weighted average (TWA).

PERSONAL PROTECTIVE EQUIPMENT

Persons working with ammonia under routine circumstances of operation and maintenance should wear flexible fitting, hooded ventilation goggles and rubber or plastic gauntlet gloves impervious to ammonia so as to protect critical body areas which are most vulnerable to contact with ammonia should a minor leak occur. A full face shield may be worn over the goggles for additional protection, but not as a substitute for the goggles.

EMERGENCY PROTECTIVE AND SAFETY EQUIPMENT

Each location having an ammonia installation should have readily available and freely accessible, emergency protective and safety equipment as may be required by federal, state, and local governmental regulations. The location of such protective and safety equipment should be well identified by appropriate signs.

Depending upon the size and nature of the installation, emergency protective and safety equipment may include one or more of the following:

SAFETY SHOWER - Parts of the body injured by contact with ammonia must be flooded immediately with large quantities of water. An emergency safety shower, eye wash fountain, or other source of clean water can be used for this purpose. Such a source should be protected from freezing in cold weather.

RESPIRATORY DEVICES -

1. A full-face GAS MASK with an ammonia (green) or a universal (red) industrial size canister approved by MSHA/NIOSH (formerly U.S. Bureau of Mines). OSHA regulations require at least two gas masks to be maintained at a stationary ammonia storage installation.

It should be noted these canisters are limited to brief periods of use not exceeding 15 minutes and in

concentrations of ammonia not exceeding 3% (30,000 ppm) in air by volume. Spare canisters, within usable date limitations as marked, should be kept on hand. Replacement of over-age canisters, even though not used, is recommended.

A person wearing a mask must leave a contaminated area immediately on detecting an odor of ammonia or experiencing difficulty in breathing. These are indications that the mask or canister is not functioning properly, that the ammonia concentration is excessive, or that adequate oxygen is not available.

2. For protection where ammonia concentrations are unknown or may exceed 3%, or in oxygen deficient atmospheres, SELF-CONTAINED AIR BREATHING APPARATUS of an approved pressure demand type should be used. This apparatus, which consists of a full face piece, a pressure and flow control and a high pressure cylinder of air, provides protection for a period of time which varies with the amount of air carried and the extent of exertion by the user.

Any respiratory device must be used and maintained in accordance with the manufacturer's instructions. Because the device is normally used in an emergency, where there is tension and excitement, a person who uses it should have received thorough training and practice.

PROTECTIVE CLOTHING - Emergency or rescue personnel required to work in high ammonia concentrations should wear protective gloves, boots, pants and jacket, or slicker impervious to ammonia. A hard hat should be worn as required by plant practice or dictated by special hazards.

RESCUE HARNESS - A safety belt and lifeline should be worn by an individual using respiratory equipment and entering contaminated air in a confined location. Another person also wearing respiratory equipment and protective clothing should be located outside the contaminated area to act in case of emergency.

WATER SYSTEM - At a large installation, a high capacity water system should be available not only for fire fighting, but also for controlling ammonia leaks.

STRETCHER AND BLANKETS - Inadequate facilities for transporting a seriously injured person from the scene of an accident to a first aid station can add to the seriousness of the injury. A stretcher provides the most acceptable method of hand transportation and it may be used as a temporary cot at the first aid station or during transit in a vehicle.

FIRST AID PROCEDURES

Ammonia is one of the most water soluble of all gases. Accordingly, the best means of providing first aid for an injury caused by ammonia contact with the eyes or skin is to flush immediately the injury area with large quantities of clean water. Promptness in initiating treatment, using adequate quantities of water and continuing its application for at least fifteen minutes, or longer if necessary, are all essential in successful first aid management of an eye or skin injury resulting from contact with ammonia. Cool coffee, tea and even a fruit flavored beverage are all reported as having been used with good effect in starting first aid treatment when water was not immediately available. A physician must be called promptly for any person who has been burned severely or overcome by ammonia. The physician should be given a complete account of the cause of injury. Speedy removal of the patient from the contaminated location is important to avoid aggravation of the injury.

PRIOR TO MEDICAL AID BY THE PHYSICIAN, FIRST AID PROCEDURES SHOULD BE EMPLOYED. THOSE PRESENTED HEREIN ARE BASED UPON WHAT IS BELIEVED TO BE COMMON PRACTICE IN INDUSTRY. THEIR ADOPTION IN ANY SPECIFIC CASE SHOULD, OF COURSE, BE SUBJECT TO PRIOR ENDORSEMENT BY A COMPETENT MEDICAL ADVISOR.

As a guide in case of injury caused by ammonia, the following first aid procedures are suggested:

INHALATION - Any conscious person who has incurred irritation due to inhalation of ammonia vapor should proceed at once to a location free of ammonia and breathe fresh air. If exposure has been minimal, usually no other treatment will be necessary.

A person overcome by ammonia must be carried to a location free of ammonia and the services of a physician obtained promptly. Successful resuscitation requires SPEED and EFFICIENCY. DELAY AND INEXPERIENCE MAY RESULT IN A FATALITY.

If there is an obstruction to the patient's breathing, the airway must be cleared by appropriate methods which may include proper positioning of the patient's head, pulling the tongue forward and clearing any blockage from the mouth such as dentures or vomitus. If spontaneous breathing does not resume after the airway has been cleared, artificial respiration should be started immediately by mouth-to-mouth resuscitation (expired-air ventilation, rescue breathing), preferably by an individual trained in the procedure.

Oxygen therapy may be indicated once the patient's breathing has been restored or if it continues to be labored. Such therapy should not replace immediate mouth-to-mouth resuscitation and should only be applied during a sustained resuscitation period or if the patient is to be moved. CAUTION: It may not be advisable to administer oxygen under positive pressure if the patient is in shock or there is impending or existing cardiovascular failure. Oxygen therapy equipment should be used only by qualified and experienced personnel.

Treatment with oxygen may be discontinued if breathing becomes easy, the color is good and there are no signs of lung congestion. During treatment, the patient should be placed in a reclining position, or if he prefers, in a sitting position. He should be kept quiet, at rest and comfortably warm, but not hot. The patient

should be examined by a physician and not allowed to return to work until found free of injury.

EYES - If contacted by ammonia, the eyes must be flooded immediately with copious quantities of clean water. Speed is essential. If contact lenses are worn, they must be removed, otherwise ammonia may be trapped underneath causing a severe burn. In isolated areas, water in a squeeze bottle which can be carried in the pocket is helpful for emergency irrigation purposes. An eye fountain should be used, but if not available, clean water from any source may be poured over the eyes. In any case, the eyelids MUST BE HELD OPEN and irrigation continued for at least 15 minutes. Repeat this procedure every ten minutes for an hour, each time irrigating for a period of five minutes until medical attention can be obtained. Such attention must be received promptly from a physician, preferably an ophthalmologist. No oils or any medication should be placed in the eyes unless ordered BY A PHYSICIAN. If prescribed BY A PHYSICIAN, 2 to 3 drops of topical anesthetic such as 1/2% tetracaine hydrochloride (Pontocaine) may be instilled to relieve pain and to permit more thorough flushing of the eyes with water.

SKIN AND MUCOSA - If contacted by liquid ammonia, the body area affected should be immediately flooded with water. If no safety shower is available, utilize any available water source. Water will have the effect of thawing out clothing which may be frozen to the skin. Such clothing should be removed and flooding of the skin with water continued for at least 15 minutes.

Do not apply salves or ointments to skin or mucous membrane burns during the 24 hour period following injury. Subsequent medical treatment is otherwise the same as for thermal burns.

INTERNAL - Swallowing of liquid ammonia is very unlikely. However, if ammonia has been taken internally and if the patient is CONSCIOUS and able, have him drink large quantities of water immediately. NEVER GIVE ANYTHING BY MOUTH TO AN

UNCONSCIOUS PERSON. Should the patient vomit, place his face down with head lower than hips to prevent vomitus from entering lungs. Transport patient to a physician promptly and apply other first aid treatment as he may prescribe.

EMERGENCY MEASURES

Every plant, warehouse, office or other facility is susceptible to emergency situations which can result in property damage and/or bodily harm to employees, visitors or even neighbors. Management bears responsibility within its own organization for the development and implementation of comprehensive and effective plans designed to meet these situations in a manner as will protect the safety of human life, physical assets and the environment to the greatest degree practicable within the constraints of governmental regulations and prudent business practice.

No one plan will serve the needs of all companies and each organization must assess the various potential emergency conditions that might occur and develop a program to suit its own requirements. Where ammonia is stored and used, the following procedures and actions are suggested for incorporation into an emergency response plan.

When an ammonia leak occurs, personnel trained for and authorized to handle such situations should take immediate steps to locate and control the condition. Respiratory equipment and protective clothing as may be necessary and suitable for ammonia must be worn. All other persons must be kept away from the affected area until the leak has been stopped. Keep on the windward side of the leak when possible.

If ammonia vapor is released, the irritating effect of the vapor will generally force personnel to leave the area before they are overcome by harmful concentrations. Sufficient, well marked and readily accessible exits must be provided to facilitate rapid

evacuation from a building. Should an individual become trapped in an ammonia contaminated atmosphere, breathing should be held to a minimum and eyes opened only as necessary. Because ammonia vapor is lighter than air, a trapped person should remain close to the floor to take advantage of lower vapor concentrations while seeking an escape route, unless liquid ammonia has been spilled. If respiratory equipment is not available, some temporary protection may be afforded by holding a wet cloth over the nose and mouth.

Should a leak occur which is extensive, such as might be involved with a spill of liquid ammonia, all persons in the path of the vapor should be warned. If necessary, local emergency authorities should be contacted to control evacuation. The evacuation area should be adjusted according to wind changes and observed effects on population. Suggested evacuation distances are given in Table 3, starting with the circle as shown in the accompanying diagram.

With good ventilation or rapidly moving air currents, ammonia vapor, being lighter than air, can be expected to dissipate readily to the upper atmosphere. Further action may not be required other than to stop the leak. If necessary, the concentration of ammonia vapor in the air can be reduced effectively by the use of an adequate volume of water applied through a spray or fog nozzle.

Under some conditions, ammonia in a container may be colder than the available water supply. At such times, water must not be applied to the container walls since heat would be transferred to the ammonia thus causing increased pressure within the container resulting in aggravation of any leakage or relief valve discharge.

Water should not be applied to a liquid spill unless at least 100 parts of water to one part of ammonia are available. Runoff of a liquid spill should be diverted if the direction of flow will create an additional problem. **UNDER NO CIRCUMSTANCES**

SHOULD AN ATTEMPT BE MADE TO NEUTRALIZE AN AMMONIA SPILL WITH AN ACID.

It is recommended that an up-to-date telephone listing of various emergency, rescue, medical and regulatory agencies be maintained for use by designated personnel should it become necessary to call for sources of outside help to cope with a situation which is beyond the self-sufficiency of local plant employees. Included in the listing should be numbers for fire and police departments, ambulance, rescue or paramedical services, doctors, hospitals, governmental authorities, material and equipment suppliers. Also listed should be the names and numbers for selected company supervisory and management personnel (such as foreman, superintendent, safety and public relations directors, etc.) who are to be notified of an

emergency situation. Where appropriate, both day and night or alternate numbers should be shown.

If company or security personnel are not present at a facility during off-hours, the name(s) and telephone number(s) of a responsible individual(s) should be posted at a gate or entrance for purposes of notification by local authorities should an emergency arise.

LEAK DETECTION

An ammonia leak is readily detectable by its characteristically pungent odor.

TABLE 3

Table of Initial Isolation and Protective Action Distances

Small Spill

- A) Downwind Distance: 0.2mi
- B) Crosswind Distance: 0.2mi
- C) Isolation Zone Diameter: 150 ft.

Large Spill

- A) Downwind Distance: 1 mi.
- B) Crosswind Distance: 1 mi.
- C) Isolation Zone Diameter: 300 ft.

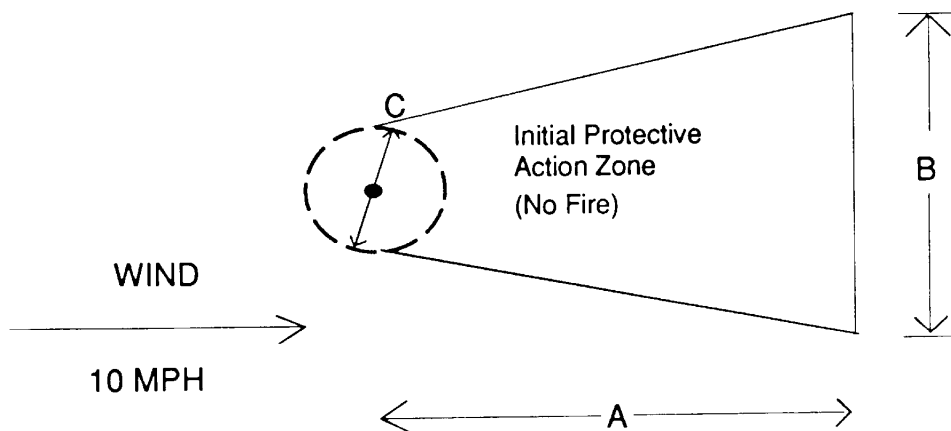

(Derived from "Guidebook for First Reponse to Hazardous Materials Incidents" - 1990, U.S. Department of Transportation P5800.5)

The location of a small leak may often be determined by holding a moist strip of phenolphthalein or red litmus paper near the suspected leak source. The rapidity and intensity of the color change in the paper will give some indication of leak proximity or size. In the presence of ammonia, phenolphthalein paper will turn from white to pink or deep red, whereas the red litmus will become blue.

Sulfur dioxide vapor reacts with ammonia to form a dense white cloud and may be used for leak detection. Care must be exercised to avoid breathing sulfur dioxide vapor as it is also highly irritating. It should be noted that a gas mask canister which is specific for ammonia will not offer protection against sulfur dioxide. If there is an appreciable quantity of ammonia in the air, it may be difficult to pinpoint the leak source.

Various types of devices are available to detect and measure the concentration of ammonia vapor in air. One such device employs a colorimetric detector tube through which air to be tested is drawn by a special hand or battery operated pump. A comparison of the length of the color stain produced in the tube is made with a calibrated chart which gives an indication of the concentration.

LEAK CONTROL

EQUIPMENT OR PIPING - If a leak occurs in equipment or piping, shut off the ammonia supply and carefully vent all ammonia from the system before attempting to dismantle any part or make repairs. The appearance of frost on an external surface indicates the presence of liquid ammonia vaporizing in the system. Accordingly, the frost should be allowed to dissipate before breaking any connection. If welding is required, the system should be thoroughly purged until all ammonia and any oil residue has been removed. Welding must conform with applicable codes.

VALVE - A leak at a valve stem can usually be stopped by tightening the packing gland nut. A leak at a valve bonnet may be stopped by tightening the bonnet threads or the bolts holding the bonnet to the valve body. All tightening should be performed slowly and without application of excessive force. Packing gland nut and bonnet threads on some ammonia valves are left-handed. If tightening procedures fail to stop the leak, the valve should be closed. If the valve should fail to close completely, it should be plugged.

PRESSURE RELIEF DEVICE - A leak or discharge through a pressure relief device, such as a pressure relief valve or hydrostatic relief valve, may occur if the pressure within the equipment, piping, tank or container exceeds the rated pressure setting of the device or if the device is faulty. Reducing the pressure within the system by removing ammonia as a vapor to process or cooling the container with a water spray may permit the device to reseal. If resealing does not take place, it most often will be necessary to replace the device with one approved for ammonia service and of the proper pressure rating and capacity.

No attempt should be made to plug, cap or otherwise tamper with a pressure relief device under any circumstances. However, a pressure relief valve may sometimes be provided with a shut-off valve in an arrangement whereby the leaking device can be isolated for removal purposes while another pressure relief valve(s) provides not less than the full rate of discharge capacity required for safety. Unless returned to the manufacturer, a pressure relief device should not be repaired or adjusted in any manner. Pressure relief valves should be replaced at regular intervals as suggested by the manufacturer. Failure to observe these precautions could result in a serious weakening or catastrophic rupture of the equipment, piping, tank or container which was being protected by the device.

STORAGE TANK - A leak at a threaded or flanged storage tank opening may often be stopped by

a careful tightening of threads or bolts. Should such efforts fail, it will be necessary to empty the tank of all ammonia before attempting further repair. If the leak is small, the tank can frequently be emptied by removing the ammonia as a vapor or liquid to process. If necessary to remove the ammonia promptly, or if the tank is equipped with a vaporizer, your supplier should be contacted for advice and assistance.

Occasionally, a storage tank will develop a leak in a plate, weld or coupling. No attempt to repair such a leak should be made. Instead, call your tank or ammonia supplier promptly. Welding on an ammonia storage tank must be performed in accordance with ASME code procedures and only after complete purging.

SHIPPING CONTAINER - Ammonia is shipped in special containers which are fabricated, transported and maintained in accordance with U.S. Department of Transportation regulations. Shipping containers include cylinders, portable tanks, tank trucks, rail tank cars, barges and tankers. If an ammonia leak occurs in a shipping container while at the user's facility, these actions should be taken to limit and control the escape of ammonia:

- (1) If liquid is leaking from a cylinder, position it if possible so that vapor instead of liquid escapes. The quantity of ammonia released from a vapor leak is considerably less than from a liquid leak through an opening of the same size.
- (2) If possible, move the container to an area of reduced hazard.
- (3) If no risk is entailed, attempt to reduce the pressure in the container by removing the ammonia to process as a vapor.
- 4) Reduce the quantity of vapor in the atmosphere with a water spray applied to the leak area.
- (5) Aside from trying to stop a leak from a shipping container by tightening a valve packing

nut, closing a valve or possibly tightening a flange bolt, no other repairs should be attempted or authorized by the user.

(6) It is a violation of federal regulations to transport an ammonia shipping container which is leaking or damaged. If a shipping container is damaged or is leaking in a manner which cannot be handled by personnel at the site, the nearest office of the producer or supplier should be called for assistance. If the producer or supplier cannot be reached, contact the Chemical Transportation Emergency Center (CHEMTREC) by telephoning the toll free number, 800/424-9300, (add long-distance access number if required) for advice and help day or night.

When calling for assistance, be prepared to provide the following information:

- (a) Nature of emergency, when, where and extent.
- (b) Type and condition of container.
- (c) Name of shipper or supplier.
- (d) Extent of injuries or property damage, if any.
- (e) Description of surrounding area and prevailing weather conditions.
- (f) Corrective measures being applied.
- (g) Name of caller and location now and where telephone contact may be re-established with caller or other responsible party at the emergency site.

Environmental protection and/or other regulatory authorities should be notified of an ammonia spill as may be appropriate and required by statute.

FIRE EXPOSURE

If possible, an ammonia container should be disconnected and removed immediately from the fire zone. If, for any reason, a container cannot be moved,

it should be kept cool with water spray until well after the fire is extinguished. Firefighting personnel should be equipped properly with protective clothing and respiratory equipment.

EMPLOYEE SAFETY TRAINING

Safety in working with ammonia depends on more than just the availability of personal or emergency protective equipment and clothing. Employee training in safe operation procedures, in first-aid measures and in the use of suitable operating and protective equipment, properly maintained, must also be included as an essential element in any comprehensive safety program.

Such safety training is the responsibility of management and should be given to new and old employees at periodic intervals as needed to maintain high proficiency levels. Included should be written and oral instructions followed by drills regarding the

location, purpose and use of personal and emergency protective clothing, equipment, emergency alarms, fire fighting equipment, safety showers or other water sources, first aid supplies and shut-down equipment such as valves and switches.

Training should also stress the avoidance of body contact with liquid ammonia or inhalation of gas and the reporting of equipment failures to appropriate supervisory authority.

This material has been reviewed by experienced safety, medical and other technical personnel competent to evaluate its accuracy and practicability.

Additional copies of this booklet are available by forwarding a request to LaRoche Industries at any of the office locations shown below.

Material Safety Data Sheets are also available by similar request.

REGIONAL OFFICES

Eastern

20 Meta Lane
Lodi, NJ 07644
201/472-8008

Central

1900 Spring Road
OakBrook, IL 60521
708/571-4950

Southern

1990 Lakeside Parkway, Suite 130
Tucker, GA 30084
404/691-0596

Western

15116 Canary Avenue
LaMirada, CA 90638
213/691-0596



LaRoche INDUSTRIES INC.

1100 JOHNSON FERRY ROAD, N.E.
ATLANTA, GEORGIA 30342
(404) 851-0300

SELECTED AMMONIA SAFETY REFERENCES AND TRAINING AIDS

- 1. *Safety Requirements for the Storage and Handling of Anhydrous Ammonia, ANSI-K61.1***
American National Standards Institute, Inc. (ANSI)
1430 Broadway
New York, New York 10018
212/354-3300
- 2. *Anhydrous Ammonia, Pamphlet G-2***
Compressed Gas Association, Inc. (CGA)
1235 Jefferson Davis Hwy.
Arlington, VA 22202
703/979-0900
- 3. *Agricultural Ammonia Safety, Booklet P15***
The Fertilizer Institute (TFI)
1015 18th Street, NW
Washington, DC 20036
202/861-4900
- 4. *Safe Handling of Anhydrous Ammonia, Rural Accident Protection Bulletin***
National Safety Council
Farm Department
444 North Michigan Avenue
Chicago, Illinois 6061155D
312/527-4800
- 5. *For the Rest of Your Life*, 16mm color sound film**
National Society for the Prevention of Blindness, Inc.
79 Madison Avenue
New York, New York 10016
212/684-3222

12. Index

A

A Brief History Of Henry Vogt Machine Co.	1-1
Adding Refrigerant.....	5-6
Ammonia Specification by Grade.....	5-2
Ammonia (amount required).....	5-2
Ammonia Removal.....	9-19
Assembly Drawing P24AL	1-4, 1-5, 1-6, 107
Assembly Drawing P34AL	1-8, 1-9, 1-10, 1-11
Automatic blowdown (Harvest Cycle).....	9-1
Auxiliary Controls or Equipment	3-18

B

Basic Product Warranty	inside back cover
Bearing Bracket and Cutter Disc Removal	9-10
Belt Tension.....	9-27
Belt Replacement.....	9-27
Bin Level Control	6-1
Blowdown	9-1

C

Charging From Tank Truck.....	5-3
Charging From Cylinders	5-3
Charging Refrigeration System (Precautions)	1-3, 5-2
Charging Valve-Freezer (28).....	
P24AL	1-4
P34AL	1-8
Check Valve (101)	1-11, 9-25
Circulating Water Pump Motor	9-23
Cleaning Procedure (Ice Making Section).....	7-3
Cleaning Ice Making Section.....	9-1
Compressor (Optional)	7-6
Compressor Inspection	9-26
Compressor Maintenance (Optional)	7-7
Compressor Loosing Oil Excessively	8-10
Compressor Oil Changing	9-24
Compressor Running Unloaded During Freeze.....	8-9
Compressor Servicing	9-26
Condenser Cleaning.....	9-6
Control Circuit Protection.....	9-5
Control Panel	5-5, 6-2, 6-3
Control Panel Parts.....	6-2, 6-3
Cooling Tower.....	3-12
Cooling Tower/ Evap Condenser	7-5
Cooling Tower Piping Diagram	3-14, 13-15
Crushed Ice Production.....	10-2
Current Unbalance	3-17
Cutter Adapter Plate Installation	9-18
adjustment	9-18
Cutter Assembly (P24AL)	9-14
parts list	9-15, 9-16
Cutter Assembly Removal and Installation.....	9-10
Cutter Blade Replacement	9-17
adjustment	9-18
Cutter Disc Removal.....	9-10

Cutter Gear Reducer	7-7, 9-7
drive gear replacement	9-7
gear reducer replacement	9-8
Cutter Height Adjustment	9-3
Cutter Motor Starters.....	10-13
Cutter Ring Gear Replacement	9-7
Cutter Parts Weights	9-9
Cutter Shaft & Bearing Removal/Installation	9-11

D

Description Of Machine	2-1
Draining Oil Trap.....	9-21
Drive Gear Replacement	9-7

E

Electrical Schematic, All Voltages 50-60 Hz.....	6-4
Electrical Controls.....	6-1

F

Float Switch	9-1
Float Switch Stop Valve (10A).....	1-9
Float Valve (Make-Up Water).....	9-1
Flushing Water In	3-11

Foundation.....

foundation layout for P24AL	3-4
foundation layout for P34AL	3-7
Freeze Period.....	4-1
Freeze Protection Diagram.....	3-15, 3-16
Freeze-Up Due To Extended Freeze Period	8-4
Freeze-Up Due To Ice Failing To Discharge.....	8-5
Freezer Drain Valve (61)	1-6, 1-11
Freezer Pressure Switch (2PS).....	9-4
Freezer Purge Valve (76).....	1-7, 1-10
Freezer Safety Valves (51).....	1-6, 1-9, 3-13
Freezer Timer	9-2

G

Gage Glass Stop Valve (31)	1-6
Gear Reducer Replacement	9-8

H

Hand Expansion Valve (17)	1-4, 1-8, 9-2
Harvest Period	4-2
Head Pressure	8-8
High Compressor Discharge Temperature.....	8-11
High Discharge Pressure	8-8
Heat Rejection	3-13
High Suction Pressure	8-9
How Your Tube-Ice Machine Works.....	4-1

I

Ice Lb./Kg Harvest	2-2
--------------------------	-----

INDEX

Ice-Making Section (Cleaning Procedure)-----	7-3
Ice Quality-----	8-7
Important Safety Notice-----	1-2
Initial Torque Adjustment (Soft Starter)-----	10-13
Inspection, First Arrival-----	2-1
Installation-----	3-1
Installation Review: A Checklist-----	3-26
J, K	
L	
Length of Ice-----	10-2
Lifting Procedures-----	3-1
lifting diagram for P24AL-----	3-8
lifting diagram for P34AL-----	3-9
Liquid Feed Solenoid Valve (20)-----	1-7, 1-8, 9-24, 9-25
Liquid Line Stop Valve(29)-----	1-4, 1-6,1-7, 1-8
Low Discharge Pressure-----	8-9
Low Ice Capacity-----	8-6, 8-7
Low Pressure Gage Stop Valve (69)-----	1-12
M	
Machine Room-----	3-1
Machine Short Cycles-----	8-11
Machine Stopped-----	8-2, 8-3
Maintenance Checklist-----	7-1
Maintenance Program (form)-----	7-2
Make-Up Water Float Valve (12)-----	1-9
Make-Up Water Flow Rate-----	11-4
Make-Up Water In-----	3-11
Make-Up Water Temperature-----	2-3
Make-Up Water Stop Valve(62)-----	1-4
Make-Up Water Usage (P24AL and P34AL)-----	11-6
Manual Harvest Push Button (3PB)-----	5-5, 6-3
Metric Conversion-----	11-8
Mitsubishi PLC-----	10-3
Model Designation Chart-----	2-2
Model P24AL (drawings)-----	
front side view-----	1-4
right side view-----	1-5
back side view-----	1-6
left side view-----	1-7
Model P34AL (drawings)-----	
front side view-----	1-8
right side view-----	1-9
back side view-----	1-10
left side view-----	1-11
N	
NEMA 1-----	3-1
Non-Condensable Gases-----	9-20
Normal Operating Vitals (P24AL and P34AL)-----	11-5
O	
Operating Features-----	4-1
Operating Tips-----	5-6
Operating Vitals (P24AL and P34AL)-----	11-5
Operating Weight-----	2-3
P	
P24AL-----	
heat rejection-----	3-13
make-up water usage-----	11-4
normal operating vitals-----	11-5
specifications-----	11-2
P34AL-----	
heat rejection-----	3-13
make-up water usage-----	11-4
normal operating vitals-----	11-5
specifications-----	11-3
Piping and Drain Connections-----	3-11
Piping Nomenclature-----	4-2
Piping Schematic for P24AL-----	4-3
Piping Schematic for P34AL-----	4-4
PLC (Programmable Logic Controller)-----	10-3, 10-5
alarm relay-----	10-4
automatic restart-----	10-4
blowdown adjustment-----	10-4
changing the setup values-----	10-10
compressor overload-----	10-9
conveyor control contacts-----	10-5
PLC (Programmable Logic Controller)-----	Continued
cutter delay-----	10-4
cutter or pump overload-----	10-8
diagnostic indicators-----	10-4
estimated ice production-----	10-5
getting started-----	10-6
hi/lo pressure-----	10-8
long or short cycle safety-----	10-9
low oil pressure-----	10-8
machine faults-----	10-8
monitoring functions-----	10-11
timed freeze cycle-----	10-4
wiring schematic-----	10-12
Poor Ice Quality-----	8-7
Power Supply Connection-----	3-16
Pressure-Temperature Chart-----	11-7
Preventive Maintenance-----	7-1
Preventive Maintenance Form-----	7-2
Preview-----	1-1
Principle of Operation-----	4-1
Production Check-----	7-2
Pumpdown-----	9-19
Purging Non-Condensables-----	9-20
Q	
R	
R - 717 (Refrigerant)-----	5-1
Rated Capacity-----	2-3
Receipt of Machine-----	2-1
inspection-----	2-1
description-----	2-1
safety tags and labels-----	2-2
Receiver Ammonia Drain Valve (44)-----	1-11
Receiver Purge Valve(59)-----	1-10

Refrigerant, Adding-----5-6
 Refrigerant Leaks -----9-19
 Refrigerant Charge-----5-2
 Refrigerant, Removal-----9-18
 Refrigeration System Review -----5-1
 Removing Excess Water from Ammonia -----9-21
 Rotation Check -----3-17

S

Safety Notice-----1-2
 Safety Switches-----6-1
 Safety Symbols and What They Mean -----1-2
 Safety Tags And Labels-----2-2
 Safety Valves -----3-13
 ----- see figures 1-6 through 1-11 for location
 Servicing Operations-----9-1
 Shipping weight -----2-3
 Soft Start Cutter Motor Starters -----10-13
 initial torque adjustment -----10-13
 start time adjustment -----10-13
 wiring-----10-13
 Solenoid Valves -----9-3
 ----- see figures 1-1 through 1-9 for location
 Space Requirements -----3-1
 Space Diagram (P24AL) -----3-2, 3-3
 Space Diagram (P34AL) -----3-5, 3-6
 Spare Parts List (P24AL and P34AL)-----11-6
 Specifications for P24AL -----2-3, 11-2
 Specifications for P34AL -----2-3, 11-3
 Start Push Button (2PB)-----5-5, 6-3
 Start Time Adjustment (Soft Starter)-----10-13
 Start-Up-----5-5
 Start-Up & Operation-----5-1
 Start-Up Checklist-----5-2
 Storage (prior to installation and start-up)-----2-3
 Stop Push Button (1PB)-----5-5, 6-3
 Suction Line Frosting to Compressor -----8-12
 Suction Regulating Valve-----3-12, 5-7

T

Temperature-Pressure Chart -----11-7
 Thaw Gas Check Valve (101) -----1-7, 9-25
 Thaw Gas Regulating Valve (18)-----1-5, 1-9, 9-23, 9-24, 5-7
 Thaw Gas Stop Valve (90)-----1-5, 1-9
 Thawing Timer (2TR) -----9-5
 Three Way Valve (52)-----1-6, 1-10
 Troubleshooting -----8-1

U

V

Valves-----9-22
 Valves (location) ----- see figures 1-1 through 1-12
 Voltage Unbalance -----3-16

W

Warranty (Basic Product) ----- inside back cover
 Water Cooled Condenser Cleaning-----9-6
 Water Distributors-----

chart-----7-3
 cleaning procedure-----7-4
 Water Flush Solenoid Valve (63) -----1-4, 1-9, 9-26
 Water Tank -----7-4, 9-13, 9-15
 Water Tank Drain Valve (39)-----1-4, 1-9
 Water Tank and Cutter Parts Weights -----9-9
 Water Tank Assembly (P24AL)-----9-15
 parts list-----9-16
 Water Tank Drain -----3-11
 Water Tank Installation-----9-13
 Water Tank Overflow-----3-11
 Water Tank Removal -----9-9
 Wiring and Electrical Connections -----3-16
 Wiring (Soft Starter) -----10-13
 Wiring Schematic, All Voltages - 50/60 Hz-----6-4

X

Y, Z

